

**BASIC ELECTRICAL AND ELECTRONICS ENGINEERING
LECTURE NOTES**

DEPARTMENT OF MECHANICAL ENGINEERING

UNIT – I

ELECTRIC CIRCUITS, ELECTROMAGNETISM AND INSTRUMENTS

INTRODUCTION

Given an electrical network, the network analysis involves various methods. The process of finding the network variables namely the voltage and currents in various parts of the circuit is known as network analysis. Before we carry out actual analysis it is very much essential to thoroughly understand the various terms associated with the network. In this chapter we shall begin with the definition and understanding in detail some of the commonly used terms. The basic laws such as Ohm's law, KCL and KVL, those can be used to analyse a given network Analysis becomes easier if we can simplify the given network. We will be discussing various techniques, which involve combining series and parallel connections of R, L and C elements.

SYSTEMS OF UNITS

As engineers, we deal with measurable quantities. Our measurement must be communicated in standard language that virtually all professionals can understand irrespective of the country. Such an international measurement language is the International System of Units (SI). In this system, there are six principal units from which the units of all other physical quantities can be derived.

Quantity	Basic Unit	Symbol
Length	Meter	M
Mass	kilogram	kg
Time	second	s
Electric Current	ampere	A
Temperature	Kelvin	K
Luminous intensity	candela	Cd

One great advantage of SI unit is that it uses prefixes based on the power of 10 to relate larger and smaller units to the basic unit.

Multiplier	Prefix	Symbol
10^{12}	Tera	T
10^9	giga	G
10^6	mega	M
10^3	kilo	K
10^{-3}	milli	m
10^{-6}	micro	
10^{-9}	nano	n
10^{-12}	pico	p

BASIC CONCEPTS AND DEFINITIONS

CHARGE

The most basic quantity in an electric circuit is the electric charge. We all experience the effect of electric charge when we try to remove our wool sweater and have it stick to our body or walk across a carpet and receive a shock.

Charge is an electrical property of the atomic particles of which matter consists, measured in coulombs (C). Charge, positive or negative, is denoted by the letter q or Q.

We know from elementary physics that all matter is made of fundamental building blocks known as atoms and that each atom consists of electrons, protons, and neutrons. We also know that the charge

'e' on an electron is negative and equal in magnitude to 1.602×10^{-19} C, while a proton carries a positive charge of the same magnitude as the electron and the neutron has no charge. The presence of equal numbers of protons and electrons leaves an atom neutrally charged.

CURRENT

Current can be defined as the motion of charge through a conducting material, measured in Ampere (A). Electric current, is denoted by the letter i or I .

The unit of current is the ampere abbreviated as (A) and corresponds to the quantity of total charge that passes through an arbitrary cross section of a conducting material per unit second.

Mathematically,

—

Where Q is the symbol of charge measured in Coulombs (C), I is the current in amperes (A) and t is the time in second (s).

The current can also be defined as the rate of charge passing through a point in an electric circuit. Mathematically,

—

The charge transferred between time t_1 and t_2 is obtained as

A constant current (also known as a direct current or DC) is denoted by symbol I whereas a time-varying current (also known as alternating current or AC) is represented by the symbol i or I . Figure 1.1 shows direct current and alternating current.

Current is always measured through a circuit element as shown in Fig. 1.1

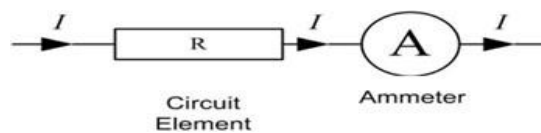

Fig. 1.1 Current through Resistor (R)

Two types of currents:

- 1) A direct current (DC) is a current that remains constant with time.
- 2) An alternating current (AC) is a current that varies with time.

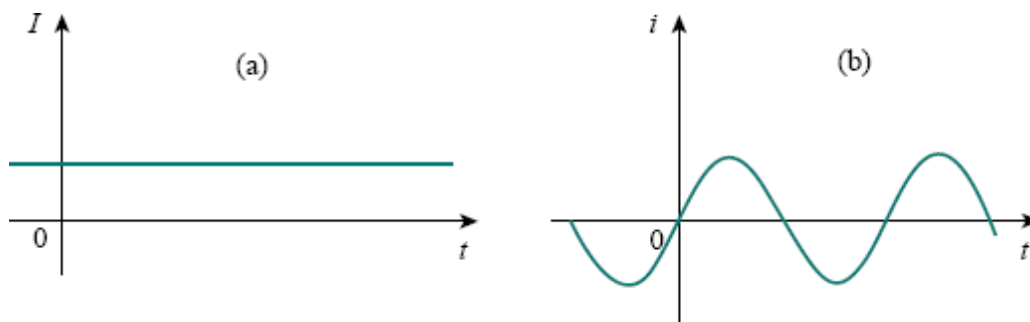

Fig. 1.2 Two common types of current: (a) direct current (DC), (b) alternative current (AC)

Example 1.1

Determine the current in a circuit if a charge of 80 coulombs passes a given point in 20 seconds (s).

Solution:

— —

Example 1.2

How much charge is represented by 4,600 electrons?

Solution:

Each electron has -1.602×10^{-19} C. Hence 4,600 electrons will have:

$$-1.602 \times 10^{-19} \times 4600 = -7.369 \times 10^{-16} \text{ C}$$

Example 1.3

The total charge entering a terminal is given by $q = 5 \sin 4t$. Calculate the current at $t = 0.5$.

Solution:

— —

$$i = \frac{dq}{dt} = 20 \cos 4t$$
$$i = 20 \cos 2 = 31.42$$

Example 1.4

Determine the total charge entering a terminal between $t = 1$ and $t = 2$ if the current passing the terminal is $i = 3e^{-2t}$.

Solution:

— —

VOLTAGE (or) POTENTIAL DIFFERENCE

To move the electron in a conductor in a particular direction requires some work or energy transfer. This work is performed by an external electromotive force (emf), typically represented by the battery in Fig. 1.3. This emf is also known as voltage or potential difference. The voltage v_{ab} between two points a and b in an electric circuit is the energy (or work) needed to move a unit charge from a to b.

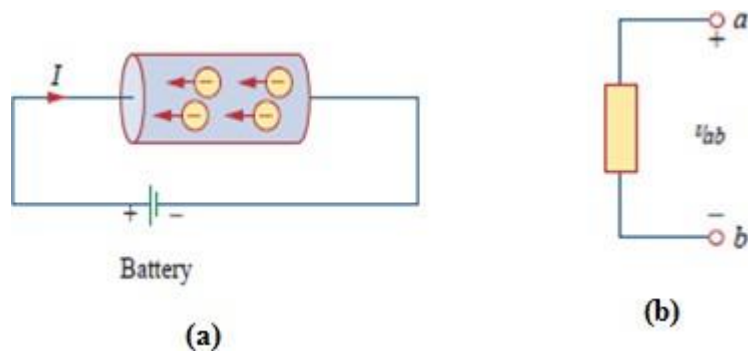

Fig. 1.3(a) Electric Current in a conductor, (b) Polarity of voltage v_{ab}

Voltage (or potential difference) is the energy required to move charge from one point to the other, measured in volts (V). Voltage is denoted by the letter v or V.

Mathematically,

where w is energy in joules (J) and q is charge in coulombs (C). The voltage v_{ab} or simply V is measured in volts (V).

$$1 \text{ volt} = 1 \text{ joule/coulomb} = 1 \text{ newton-meter/coulomb}$$

Fig. 1.3 shows the voltage across an element (represented by a rectangular block) connected to points a and b . The plus (+) and minus (-) signs are used to define reference direction or voltage polarity. The v_{ab} can be interpreted in two ways: (1) point a is at a potential of v_{ab} volts higher than point b , or (2) the potential at point a with respect to point b is v_{ab} . It follows logically that in general

Voltage is always measured across a circuit element as shown in Fig. 1.4

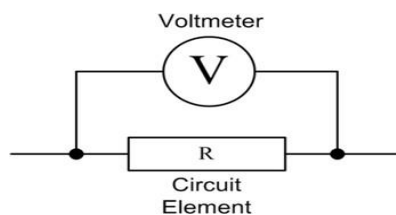

Fig. 1.4 Voltage across Resistor (R)

Example 1.5

An energy source forces a constant current of 2 A for 10 s to flow through a lightbulb. If 2.3 kJ is given off in the form of light and heat energy, calculate the voltage drop across the bulb.

Solution:

$$\text{Total charge } dq = i \cdot dt = 2 \cdot 10 = 20 \text{ C}$$

The voltage drop is _____

4 POWER

Power is the time rate of expending or absorbing energy, measured in watts (W). Power, is denoted by the letter p or P .

Mathematically,

Where p is power in watts (W), w is energy in joules (J), and t is time in seconds (s).

From voltage and current equations, it follows that;

Thus, if the magnitude of current I and voltage are given, then power can be evaluated as the product of the two quantities and is measured in watts (W).

Sign of power:

Plus sign: Power is absorbed by the element. (Resistor, Inductor)

Minus sign: Power is supplied by the element. (Battery, Generator)

Passive sign convention:

If the current enters through the positive polarity of the voltage, $p = +vi$
 If the current enters through the negative polarity of the voltage, $p = -vi$

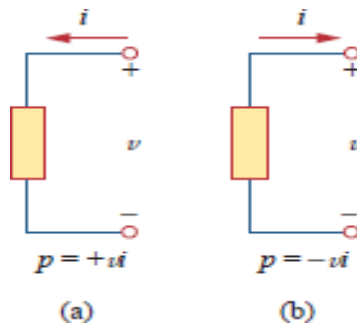

Fig 1.5 Polarities for Power using passive sign convention
 (a) Absorbing Power (b) Supplying Power

1.3.5 ENERGY

Energy is the capacity to do work, and is measured in joules (J).
 The energy absorbed or supplied by an element from time 0 to t is given by,

The electric power utility companies measure energy in watt-hours (WH) or Kilo watt-hours (KWH)

$$1 \text{ WH} = 3600 \text{ J}$$

Example 1.6

A source e.m.f. of 5 V supplies a current of 3A for 10 minutes. How much energy is provided in this time?

Solution:

$$= \quad = 5 \times 3 \times 10 \times 60 = 9$$

Example 1.7

An electric heater consumes 1.8Mj when connected to a 250 V supply for 30 minutes. Find the power rating of the heater and the current taken from the supply.

Solution:

$$= / = (1.8 \times 10^6) / (30 \times 60) = 1000$$

Power rating of heater = 1kW

=

Thus

$$= / = 1000 / 250 = 4$$

Hence the current taken from the supply is 4A.

Example 1.7

Find the power delivered to an element at $t=3$ if the current entering its positive terminals is $i=5\cos 60$ and the voltage is: (a) $v=3$, (b) $v=3\sin 60$.

Solution:

(a) The voltage is $v=3=15\cos 60$; hence, the power is: $p=i v=75\cos 260$

At $t=3$,

$$p=75\cos 260 \times 3 \times 10^{-3} = 53.48$$

(b) We find the voltage and the power as

$$v=3=3-60 \sin 60 = -900 \sin 60$$

$$p=i v = -4500 \sin 60 \cos 60$$

$$At = 3 ,$$

$$= -4500 \sin 0.18 \cos 0.18 = -6.396$$

OHM'S LAW

Georg Simon Ohm (1787–1854), a German physicist, is credited with finding the relationship between current and voltage for a resistor. This relationship is known as Ohm's law.

Ohm's law states that at constant temperature, the voltage (V) across a conducting material is directly proportional to the current (I) flowing through the material.

Mathematically,

$$V \propto I$$

$$V = RI$$

Where the constant of proportionality R is called the resistance of the material. The V-I relation for resistor according to Ohm's law is depicted in Fig. 1.6

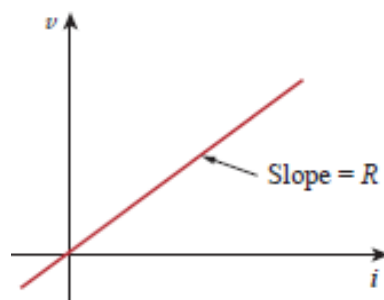

Fig. 1.6 V-I Characteristics for resistor

Limitations of Ohm's Law:

1. Ohm's law is not applicable to non-linear elements like diode, transistor etc.
2. Ohm's law is not applicable for non-metallic conductors like silicon carbide.

CIRCUIT ELEMENTS

An element is the basic building block of a circuit. An electric circuit is simply an interconnection of the elements. Circuit analysis is the process of determining voltages across (or the currents through) the elements of the circuit.

There are 2 types of elements found in electrical circuits.

- a) **Active elements (Energy sources):** The elements which are capable of generating or delivering the energy are called active elements.
E.g., Generators, Batteries
- b) **Passive element (Loads):** The elements which are capable of receiving the energy are called passive elements.
E.g., Resistors, Capacitors and Inductors

ACTIVE ELEMENTS (ENERGY SOURCES)

The energy sources which are having the capacity of generating the energy are called active elements. The most important active elements are voltage or current sources that generally deliver power/energy to the circuit connected to them.

There are two kinds of sources

- a) Independent sources
- b) Dependent sources

INDEPENDENT SOURCES:

An ideal independent source is an active element that provides a specified voltage or current that is completely independent of other circuit elements.

Ideal Independent Voltage Source:

An ideal independent voltage source is an active element that gives a constant voltage across its terminals irrespective of the current drawn through its terminals. In other words, an ideal independent voltage source delivers to the circuit whatever current is necessary to maintain its terminal voltage. The symbol of idea independent voltage source and its V-I characteristics are shown in Fig. 1.7

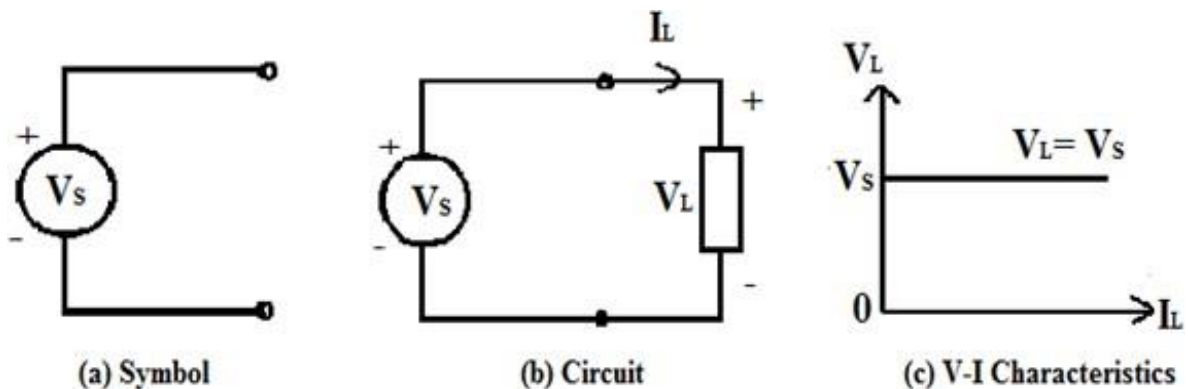

Fig. 1.7 Ideal Independent Voltage Source

Practical Independent Voltage Source:

Practically, every voltage source has some series resistance across its terminals known as internal resistance, and is represented by R_{se} . For ideal voltage source $R_{se} = 0$. But in practical voltage source R_{se} is not zero but may have small value. Because of this R_{se} voltage across the terminals decreases with increase in current as shown in Fig. 1.8

Terminal voltage of practical voltage source is given by

$$V_L = V_s - I_L R_{se}$$

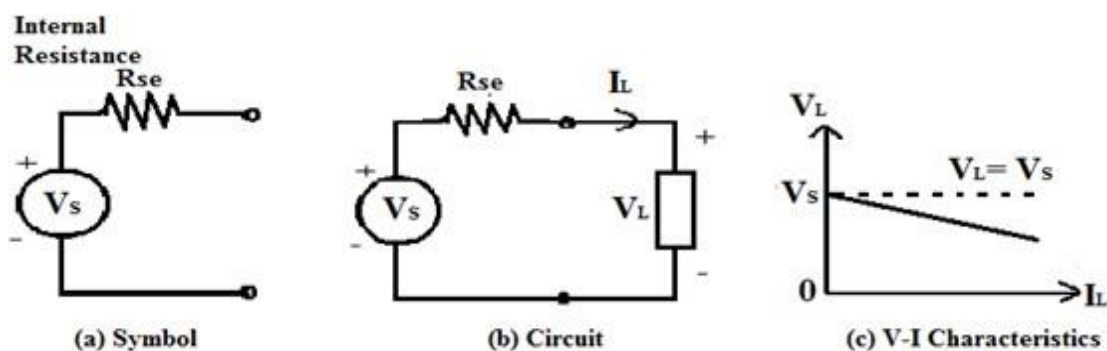

Fig. 1.8 Practical Independent Voltage Source

Ideal Independent Current Source:

An ideal independent Current source is an active element that gives a constant current through its terminals irrespective of the voltage appearing across its terminals. That is, the current source delivers to the circuit whatever voltage is necessary to maintain the designated current. The symbol of idea independent current source and its V-I characteristics are shown in Fig. 1.9

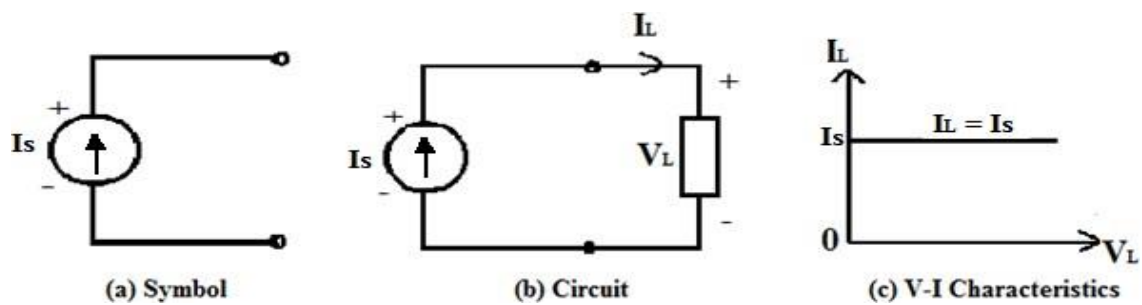

Fig. 1.9 Ideal Independent Current Source

Practical Independent Current Source:

Practically, every current source has some parallel/shunt resistance across its terminals known as internal resistance, and is represented by R_{sh} . For ideal current source $R_{sh} = \infty$ (infinity). But in practical voltage source R_{sh} is not infinity but may have a large value. Because of this R_{sh} current through the terminals slightly decreases with increase in voltage across its terminals as shown in Fig. 1.10.

Terminal current of practical current source is given by

$$I_L = I_s - I_{sh}$$

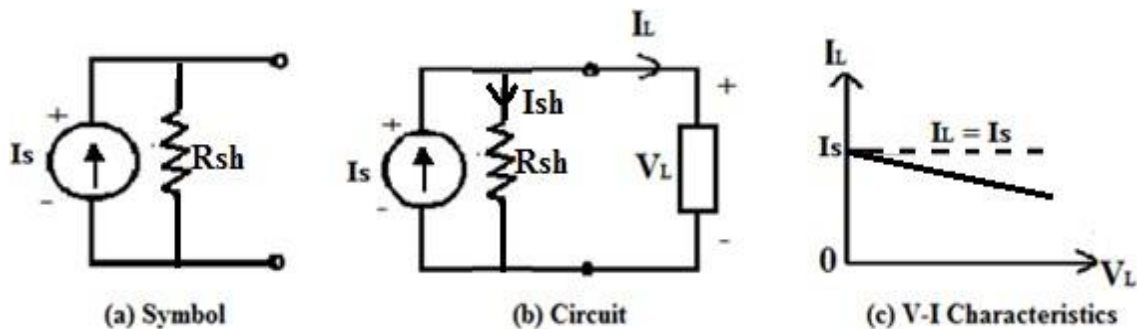

Fig. 1.10 Practical Independent Current Source

DEPENDENT (CONTROLLED) SOURCES

An ideal dependent (or controlled) source is an active element in which the source quantity is controlled by another voltage or current.

Dependent sources are usually designated by diamond-shaped symbols, as shown in Fig. 1.11. Since the control of the dependent source is achieved by a voltage or current of some other element in the circuit, and the source can be voltage or current, it follows that there are four possible types of dependent sources, namely:

1. A voltage-controlled voltage source (VCVS)
2. A current-controlled voltage source (CCVS)
3. A voltage-controlled current source (VCCS)
4. A current-controlled current source (CCCS)

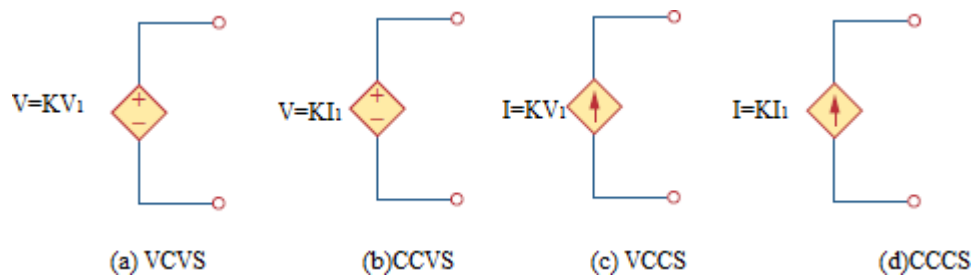

Fig. 1.11 Symbols for Dependent voltage source and Dependent current source

Dependent sources are useful in modeling elements such as transistors, operational amplifiers, and integrated circuits. An example of a current-controlled voltage source is shown on the right-hand side of Fig. 1.12, where the voltage $10i$ of the voltage source depends on the current i through element C. Students might be surprised that the value of the dependent voltage source is $10i$ V (and not $10i$ A) because it is a voltage source. The key idea to keep in mind is that a voltage source comes with polarities (+ -) in its symbol, while a current source comes with an arrow, irrespective of what it depends on.

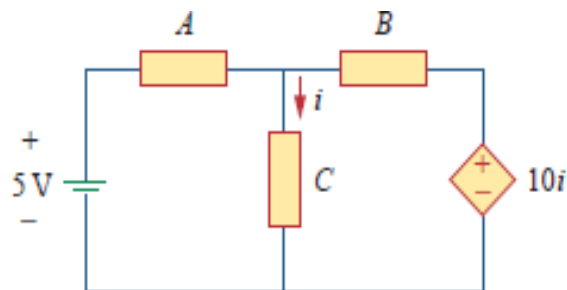

Fig. 1.12 The source in right hand side is current-controlled voltage source

PASSIVE ELEMENTS (LOADS)

Passive elements are those elements which are capable of receiving the energy. Some passive elements like inductors and capacitors are capable of storing a finite amount of energy, and return it later to an external element. More specifically, a passive element is defined as one that cannot supply average power that is greater than zero over an infinite time interval. Resistors, capacitors, Inductors fall in this category.

RESISTOR

Materials in general have a characteristic behavior of resisting the flow of electric charge. This physical property, or ability to resist the flow of current, is known as resistance and is represented by the symbol R . The Resistance is measured in ohms (Ω). The circuit element used to model the current-resisting behavior of a material is called the resistor.

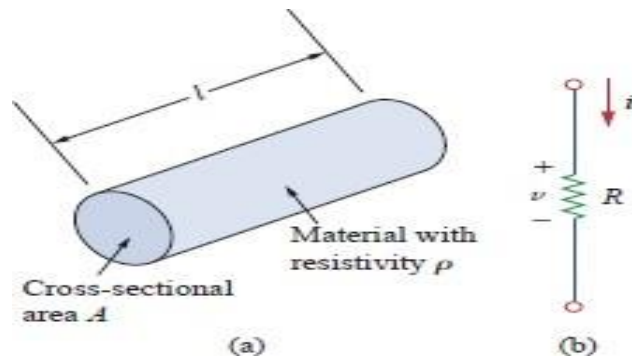

Fig. 1.13 (a) Typical Resistor, (b) Circuit Symbol for Resistor

The resistance of a resistor depends on the material of which the conductor is made and geometrical shape of the conductor. The resistance of a conductor is proportional to the its length (and inversely proportional to its cross sectional area (A). Therefore the resistance of a conductor can be written as,

—

The proportionality constant is called the specific resistance o resistivity of the conductor and its value depends on the material of which the conductor is made.

The inverse of the resistance is called the conductance and inverse of resistivity is called specific conductance or conductivity. The symbol used to represent the conductance is G and conductivity is . Thus conductivity and its units are Siemens per meter

— — — — —

By using Ohm’s Law, The power dissipated in a resistor can be expressed in terms of R as below

—

The power dissipated by a resistor may also be expressed in terms of G as

—

The energy lost in the resistor from time 0 to t is expressed as

Or

— —

Where V is in volts, I is in amperes, R is in ohms, and energy W is in joules

Example 1.8

In the circuit shown in Fig. below, calculate the current i, the conductance G, the power p and energy lost in the resistor W in 2hours.

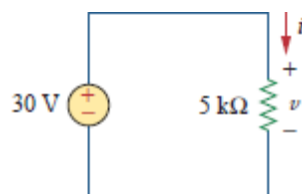

Solution:

The voltage across the resistor is the same as the source voltage (30 V) because the resistor and the voltage source are connected to the same pair of terminals. Hence, the current is

$$i = \frac{V}{R}$$

The conductance is

We can calculate the power in various ways

$$P = i^2 R$$

or

or

$$P = \frac{V^2}{R}$$

Energy lost in the resistor is

INDUCTOR

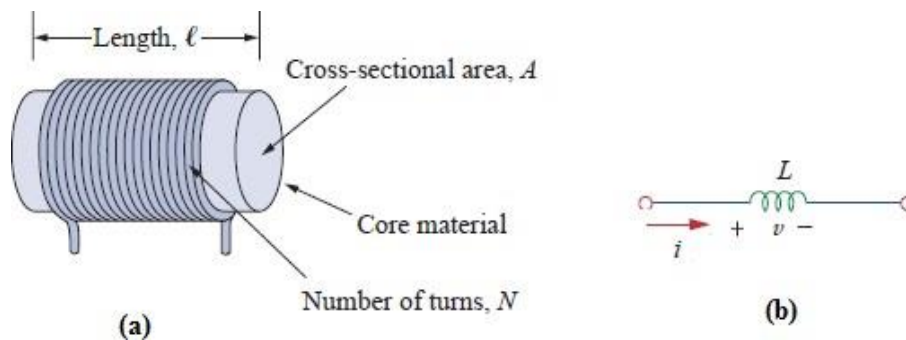

Fig. 1.14 (a) Typical Inductor, (b) Circuit symbol of Inductor

A wire of certain length, when twisted into a coil becomes a basic inductor. The symbol for inductor is shown in Fig.1.14 (b). If current is made to pass through an inductor, an electromagnetic field is formed. A change in the magnitude of the current changes the electromagnetic field. Increase in current expands the fields, and decrease in current reduces it. Therefore, a change in current produces change in the electromagnetic field, which induces a voltage across the coil according to Faraday's law of electromagnetic induction. i.e., the voltage across the inductor is directly proportional to the time rate of change of current.

Mathematically,

$$v = L \frac{di}{dt}$$

Where L is the constant of proportionality called the inductance of an inductor. The unit of inductance is Henry (H).we can rewrite the above equation as

$$v dt = L di$$

Integrating both sides from time 0 to t, we get

$$\int_0^t v dt = L \int_0^t di$$

From the above equation we note that the current in an inductor is dependent upon the integral of the voltage across its terminal and the initial current in the coil .

The power absorbed by the inductor is

The energy stored by the inductor is

From the above discussion, we can conclude the following.

1. The induced voltage across an inductor is zero if the current through it is constant. That means an inductor acts as short circuit to DC.
2. A small change in current within zero time through an inductor gives an infinite voltage across the inductor, which is physically impossible. In a fixed inductor the current cannot change abruptly i.e., the inductor opposes the sudden changes in currents.
3. The inductor can store finite amount of energy. Even if the voltage across the inductor is zero
4. A pure inductor never dissipates energy, only stores it. That is why it is also called a non-dissipative passive element. However, physical inductors dissipate power due to internal resistance.

Example 1.9

Find the current through a 5-H inductor if the voltage across it is

Also, find the energy stored at $t = 5$ s. assume initial conditions to be zero.

Solution:

The power

Then the energy stored is

1.5.2.2 CAPACITOR

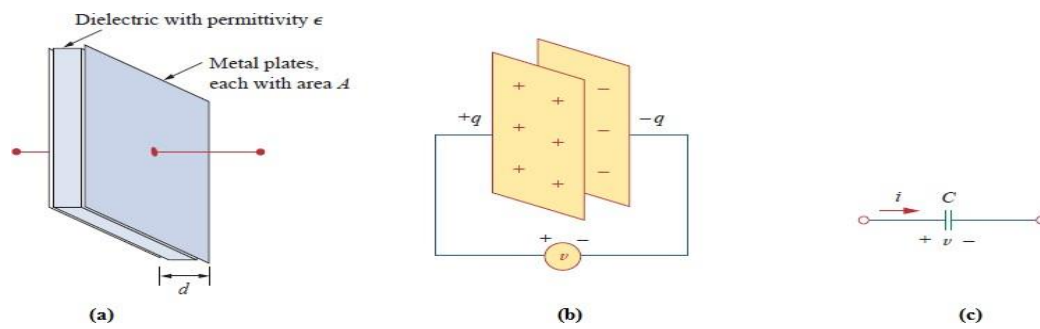

Fig. 1.15 (a) Typical Capacitor, (b) Capacitor connected to a voltage source, (c) Circuit Symbol of capacitor

Any two conducting surfaces separated by an insulating medium exhibit the property of a capacitor. The conducting surfaces are called electrodes, and the insulating medium is called dielectric. A capacitor stores energy in the form of an electric field that is established by the opposite charges on the two electrodes. The electric field is represented by lines of force between the positive and negative charges, and is concentrated within the dielectric.

When a voltage source v is connected to the capacitor, as in Fig 1.15 (c), the source deposits a positive charge q on one plate and a negative charge $-q$ on the other. The capacitor is said to store the electric charge. The amount of charge stored, represented by q , is directly proportional to the applied voltage v so that

Where C , the constant of proportionality, is known as the capacitance of the capacitor. The unit of capacitance is the farad (F).

Although the capacitance C of a capacitor is the ratio of the charge q per plate to the applied voltage v , it does not depend on q or v . It depends on the physical dimensions of the capacitor. For example, for the parallel-plate capacitor shown in Fig.1.15 (a), the capacitance is given by

$$C = \frac{\epsilon A}{d}$$

Where A is the surface area of each plate, d is the distance between the plates, and ϵ is the permittivity of the dielectric material between the plates. The current flowing through the capacitor is given by

$$i = \frac{dq}{dt}$$

$$dq = i dt$$

We can rewrite the above equation as

$$dq = C dv$$

Integrating both sides from time 0 to t , we get

$$q = Cv$$

$$i = C \frac{dv}{dt}$$

$$i dt = C dv$$

From the above equation we note that the voltage across the terminals of a capacitor is dependent upon the integral of the current through it and the initial voltage .

The power absorbed by the capacitor is

—

The energy stored by the capacitor is

— —

From the above discussion we can conclude the following,

1. The current in a capacitor is zero if the voltage across it is constant; that means, the capacitor acts as an open circuit to DC.
2. A small change in voltage across a capacitance within zero time gives an infinite current through the capacitor, which is physically impossible. In a fixed capacitance the voltage cannot change abruptly. i.e., A capacitor will oppose the sudden changes in voltages.
3. The capacitor can store a finite amount of energy, even if the current through it is zero.
4. A pure capacitor never dissipates energy, but only stores it; that is why it is called non-dissipative passive element. However, physical capacitors dissipate power due to internal resistance.

Example 1.10

Determine the current through a 200 capacitor whose voltage is shown in Fig. below

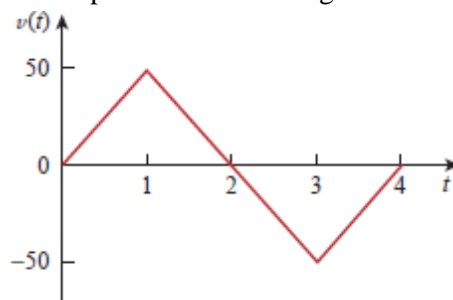

Solution:

The voltage waveform can be described mathematically as

Since we take the derivative of to obtain the i

Hence, the current wave form is as shown in the fig. below

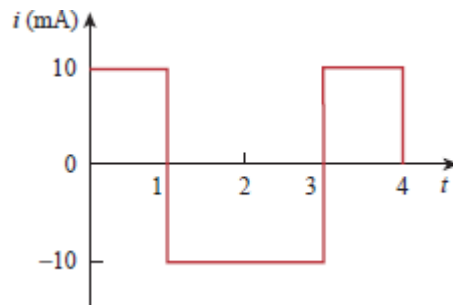

NETWORK/CIRCUIT TERMINOLOGY

In the following section various definitions and terminologies frequently used in electrical circuit analysis are outlined.

- **Network Elements:** The individual components such as a resistor, inductor, capacitor, diode, voltage source, current source etc. that are used in circuit are known as network elements.
- **Network:** The interconnection of network elements is called a network.
- **Circuit:** A network with at least one closed path is called a circuit. So, all the circuits are networks but all networks are not circuits.
- **Branch:** A branch is an element of a network having only two terminals.
- **Node:** A node is the point of connection between two or more branches. It is usually indicated by a dot in a circuit.
- **Loop:** A loop is any closed path in a circuit. A loop is a closed path formed by starting at a node, passing through a set of nodes, and returning to the starting node without passing through any node more than once.
- **Mesh or Independent Loop:** Mesh is a loop which does not contain any other loops in it.

KIRCHHOFF'S LAWS

The most common and useful set of laws for solving electric circuits are the Kirchhoff's voltage and current laws. Several other useful relationships can be derived based on these laws. These laws are formally known as Kirchhoff's current law (KCL) and Kirchhoff's voltage law (KVL).

KIRCHHOFF'S CURRENT LAW (KCL)

This is also called as Kirchhoff's first law or Kirchhoff's nodal law. Kirchhoff's first law is based on the law of conservation of charge, which requires that the algebraic sum of charges within a system cannot change.

Statement: Algebraic sum of the currents meeting at any junction or node is zero. The term 'algebraic' means the value of the quantity along with its sign, positive or negative.

Mathematically, KCL implies that

Where N is the number of branches connected to the node and i_n is the n th current entering (or leaving) the node. By this law, currents entering a node may be regarded as positive, while currents leaving the node may be taken as negative or vice versa.

Alternate Statement: Sum of the currents flowing towards a junction is equal to the sum of the currents flowing away from the junction.

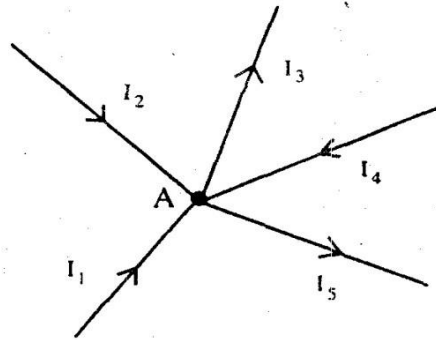

Fig 1.16 Currents meeting in a junction

Consider Fig. 1.16 where five branches of a circuit are connected together at the junction or node A. Currents I_1 , I_2 and I_4 are flowing towards the junction whereas currents I_3 and I_5 are flowing away from junction A. If a positive sign is assigned to the currents I_2 and I_4 that are flowing into the junction then the currents I_3 and I_5 flowing away from the junction should be assigned with the opposite sign i.e. the negative sign.

Applying Kirchhoff's current law to the junction A

$$I_1 + I_2 - I_3 + I_4 - I_5 = 0 \text{ (algebraic sum is zero)}$$

The above equation can be modified as $I_1 + I_2 + I_4 = I_3 + I_5$ (sum of currents towards the junction = sum of currents flowing away from the junction).

KIRCHHOFF'S VOLTAGE LAW (KVL)

This is also called as Kirchhoff's second law or Kirchhoff's loop or mesh law. Kirchhoff's second law is based on the principle of conservation of energy.

Statement: Algebraic sum of all the voltages around a closed path or closed loop at any instant is zero. Algebraic sum of the voltages means the magnitude and direction of the voltages; care should be taken in assigning proper signs or polarities for voltages in different sections of the circuit.

Mathematically, KVL implies that

Where N is the number of voltages in the loop (or the number of branches in the loop) and is the n^{th} voltage in a loop.

The polarity of the voltages across active elements is fixed on its terminals. The polarity of the voltage drop across the passive elements (Resistance in DC circuits) should be assigned with reference to the direction of the current through the elements with the concept that the current flows from a higher potential to lower potential. Hence, the entry point of the current through the passive elements should be marked as the positive polarity of voltage drop across the element and the exit point of the current as the negative polarity. The direction of currents in different branches of the circuits is initially marked either with the known direction or assumed direction.

After assigning the polarities for the voltage drops across the different passive elements, algebraic sum is accounted around a closed loop, either clockwise or anticlockwise, by assigning a particular sign, say the positive sign for all rising potentials along the path of tracing and the negative sign for all decreasing potentials. For example consider the circuit shown in Fig. 1.17

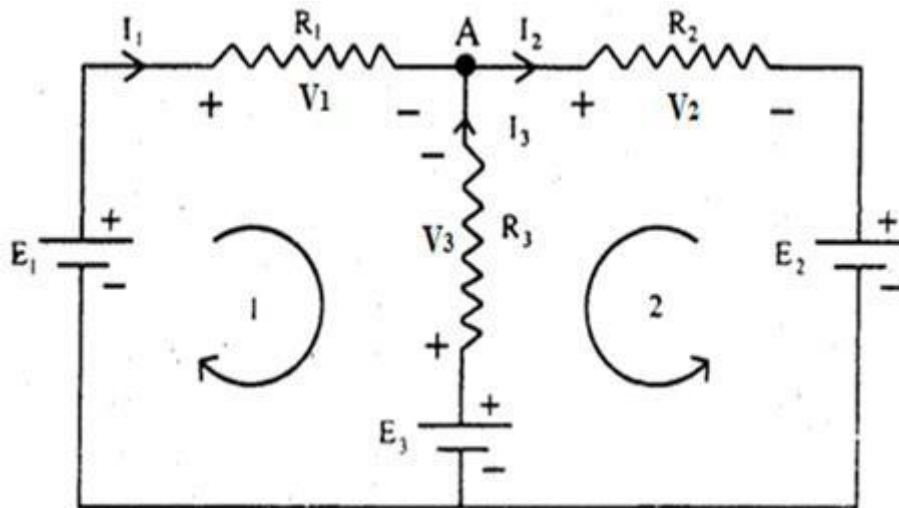

Fig. 1.17 Circuit for KVL

The circuit has three active elements with voltages E_1 , E_2 and E_3 . The polarity of each of them is fixed. R_1 , R_2 , R_3 are three passive elements present in the circuit. Currents I_1 and I_3 are marked flowing into the junction A and current I_2 marked away from the junction A with known information or assumed directions. With reference to the direction of these currents, the polarity of voltage drops V_1 , V_2 and V_3 are marked.

For loop1 it is considered around clockwise

$$\begin{aligned}
 + E_1 - V_1 + V_3 - E_3 &= 0 \\
 + E_1 - I_1 R_1 + I_3 R_3 - E_3 &= 0 \\
 E_1 - E_3 &= I_1 R_1 - I_3 R_3
 \end{aligned}$$

For loop2 it is considered anticlockwise

$$\begin{aligned}
 + E_2 + V_2 + V_3 - E_3 &= 0 \\
 + E_2 + I_2 R_2 + I_3 R_3 - E_3 &= 0 \\
 E_2 - E_3 &= - I_2 R_2 - I_3 R_3
 \end{aligned}$$

Two equations are obtained following Kirchhoff's voltage law. The third equation can be written based on Kirchhoff's current law as

$$I_1 - I_2 + I_3 = 0$$

With the three equations, one can solve for the three currents I_1 , I_2 , and I_3 .

If the results obtained for I_1 , I_2 , and I_3 are all positive, then the assumed direction of the currents are said to be along the actual directions. A negative result for one or more currents will indicate that the assumed direction of the respective current is opposite to the actual direction.

Example 1.11

Calculate the current supplied by two batteries in the circuit given below

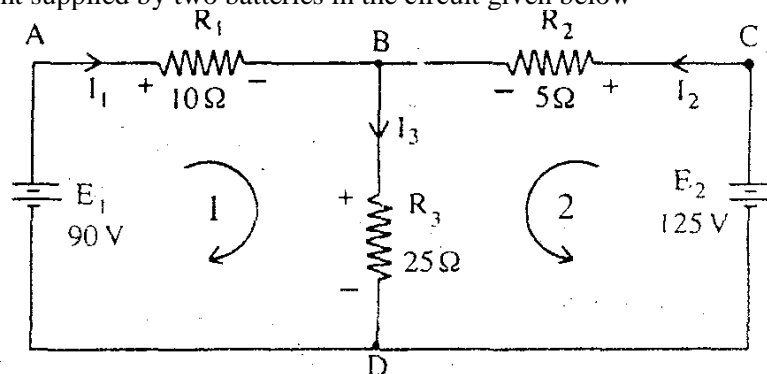

Solution:

The four junctions are marked as A, B, C and D. The current through R_1 is assumed to flow from A to B and through R_2 , from C to B and finally through R_3 from B to D. With reference to current directions, polarities of the voltage drop in R_1 , R_2 and R_3 are then marked as shown in the figure.

Applying KCL to junction B

$$I_3 = I_1 + I_2 \quad \dots\dots(1)$$

Applying KVL to loop 1

$$\begin{aligned} E_1 - I_1R_1 - I_3R_3 &= 0 \\ I_1R_1 + I_3R_3 &= E_1 \\ 10I_1 + 25I_3 &= 90 \quad \dots\dots (2) \end{aligned}$$

Substituting Eq. (1) in Eq. (2)

$$\begin{aligned} 10I_1 + 25(I_1 + I_2) &= 90 \\ 35I_1 + 25I_2 &= 90 \quad \dots\dots (3) \end{aligned}$$

Applying KVL to loop 2

$$\begin{aligned} E_2 - I_2R_2 - I_3R_3 &= 0 \\ I_2R_2 + I_3R_3 &= E_2 \\ 5I_2 + 25I_3 &= 125 \quad \dots\dots (4) \end{aligned}$$

Substituting Eq. (1) in Eq. (4)

$$\begin{aligned} 5I_2 + 25(I_1 + I_2) &= 125 \\ 25I_1 + 30I_2 &= 125 \quad \dots\dots (5) \end{aligned}$$

Multiplying Eq. (3) by 6/5 we get

$$42I_1 + 30I_2 = 108 \quad \dots\dots (6)$$

Subtracting Eq. (6) from Eq. (5)

$$\begin{aligned} -17I_1 &= 17 \\ I_1 &= -1 \text{ A} \end{aligned}$$

Substituting the value of I_1 in Eq. (5) we get

$$I_2 = 5 \text{ A}$$

As the sign of the current I_1 is found to be negative from the solution, the actual direction of I_1 is from B to A to D i.e. 90 V battery gets a charging current of 1 A.

1.8 RESISTIVE NETWORKS

1.8.1 SERIES RESISTORS AND VOLTAGE DIVISION

Two or more resistors are said to be in series if the same current flows through all of them. The process of combining the resistors is facilitated by combining two of them at a time. With this in mind, consider the single-loop circuit of Fig. 1.18.

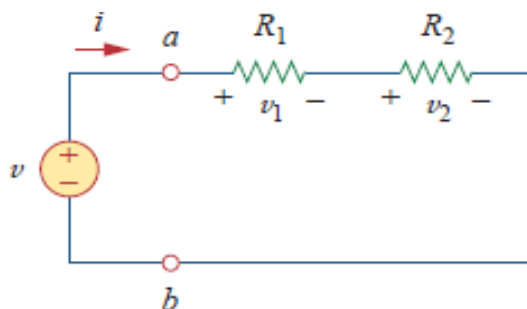

Fig.1.18 A single loop circuit with two resistors in series

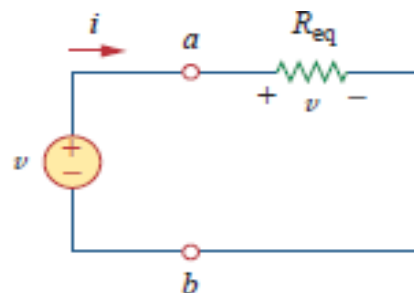

Fig. 1.19 Equivalent Circuit of series resistors

The two resistors are in series, since the same current i flow in both of them. Applying Ohm's law to each of the resistors, we obtain

If we apply KVL to the loop (moving in the clockwise direction), we have (1)

Combining equations (1) and (2), we get (2)

Or (3)

Equation (3) can be written as (4)

implying that the two resistors can be replaced by an equivalent resistor ;that is (5)

..... (6)

Thus, Fig. 1.18 can be replaced by the equivalent circuit in Fig. 1.19. The two circuits in Fig 1.18 and 1.19 are the equivalent because they because they exhibit the same voltage-current relationships at the terminals a-b. An equivalent circuit such as the one in Fig. 1.19 is useful in simplifying the analysis of a circuit.

In general, the equivalent resistance of any number of resistors connected in series is the sum of the individual resistances.

For N resistors in series then,

VOLTAGE DIVISION: (7)

To determine the voltage across each resistor in Fig. 1.18, we substitute Eq. (4) into Eq. (1) and obtain

..... (8)

Notice that the source voltage is divided among the resistors in direct proportion to their resistances; the larger the resistance, the larger the voltage drop. This is called the principle of voltage division, and the circuit in Fig. 1.18 is called a voltage divider. In general, if a voltage divider has N resistors () in series with the source voltage , the nth resistor () will have a voltage drop of

..... (9)

1.8.2 PARALLEL RESISTORS AND CURRENT DIVISION

Two or more resistors are said to be in parallel if the same voltage appears across each element.Consider the circuit in Fig. 1.20, where two resistors are connected in parallel and therefore have the same voltage across them.

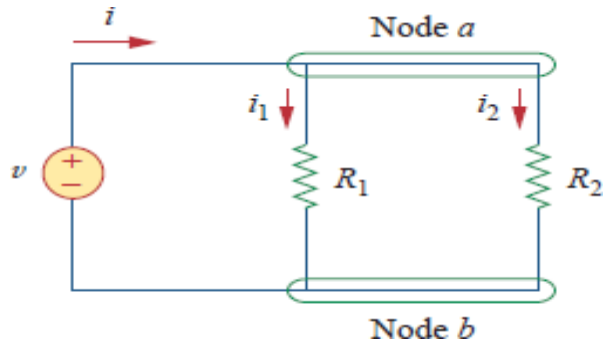

Fig. 1.20 Two resistors in parallel

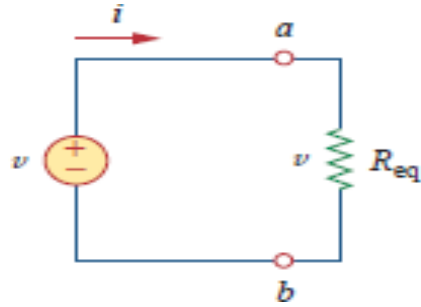

Fig. 1.21 Equivalent circuit of Fig. 1.20

..... (1)

— —

..... (2)

Applying KCL at node gives the total current as

..... (3)

Substituting Eq. (2) into Eq. (3), we get

— — — — —

..... (4)

where is the equivalent resistance of the resistors in parallel.

— — —

..... (5)

Or

—

..... (6)

Thus,

The equivalent resistance of two parallel resistors is equal to the product of their resistances divided by their sum.

It must be emphasized that this applies only to two resistors in parallel. From Eq. (6), if

We can extend the result in Eq. (5) to the general case of a circuit with N resistors in parallel. The equivalent resistance is

$$\frac{1}{R_{eq}} = \frac{1}{R_1} + \frac{1}{R_2} + \frac{1}{R_3} + \dots + \frac{1}{R_N} \quad \dots\dots\dots (7)$$

Thus,

The equivalent Resistance of parallel-connected resistors is the reciprocal of the sum of the reciprocals of the individual resistances.

Note that is always smaller than the resistance of the smallest resistor in the parallel combination.

Current Division:

Given the total current i entering node in Fig. 1.20, then how do we obtain currents ? We know that the equivalent resistor has the same voltage, or

$$i R_{eq} = i_k R_k \quad \dots\dots\dots (8)$$

Substitute (8) in (2), we get

$$i R_{eq} = i_k R_k \Rightarrow i_k = i \frac{R_{eq}}{R_k} \quad \dots\dots\dots (9)$$

This shows that the total current is shared by the resistors in inverse proportion to their resistances. This is known as the principle of current division, and the circuit in Fig.1.20 is known as a current divider. Notice that the larger current flows through the smaller resistance.

INDUCTIVE NETWORKS

Now that the inductor has been added to our list of passive elements, it is Necessary to extend the powerful tool of series-parallel combination. We need to know how to find the equivalent inductance of a series-connected or parallel-connected set of inductors found in practical circuits.

SERIES INDUCTORS

Two or more inductors are said to be in series, if the same current flows through all of them. Consider a series connection of N inductors, as shown in Fig. 1.22(a), with the equivalent circuit shown in Fig. 1.22(b). The inductors have the same current through them.

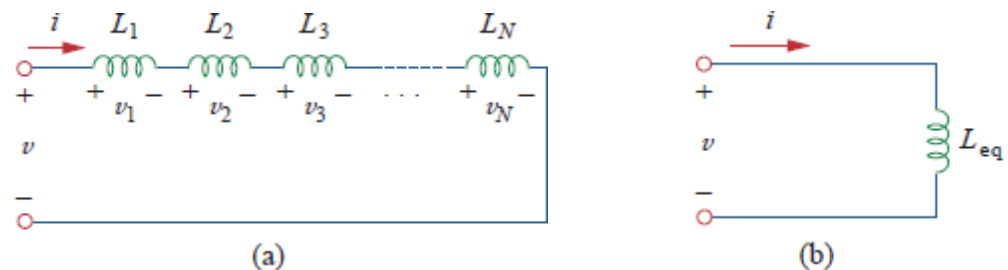

Fig. 1.22 (a) series connection of N inductors (b) Equivalent circuit for the series inductors

Applying KVL to the loop,

We know that the voltage across an inductor is —

Therefore, Eq. (1) becomes

$$v = L \frac{di}{dt}$$

Where,

Thus

The equivalent inductance of series-connected inductors is the sum of the individual inductances.

* Inductors in series are combined in exactly the same way as resistors in series.

INDUCTORS IN PARALLEL

Two or more inductors are said to be in parallel, if the same voltage appears across each element. We now consider a parallel connection of N inductors, as shown in Fig. 1.23(a), with the equivalent circuit in Fig. 1.23(b). The inductors have the same voltage across them.

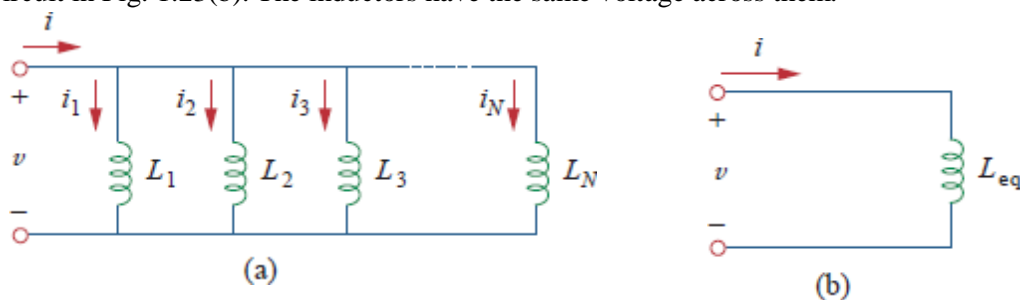

Fig. 1.23 (a) Parallel connection of N inductors (b) Equivalent circuit for parallel inductors

Using KCL,

But the current through the inductor is

$$i = i_1 + i_2 + i_3 + \dots + i_N$$

If we neglect the initial value of current i.e, then current through inductor becomes

$$i = L \frac{di}{dt}$$

Hence,

$$\frac{1}{L_{eq}} = \frac{1}{L_1} + \frac{1}{L_2} + \frac{1}{L_3} + \dots + \frac{1}{L_N}$$

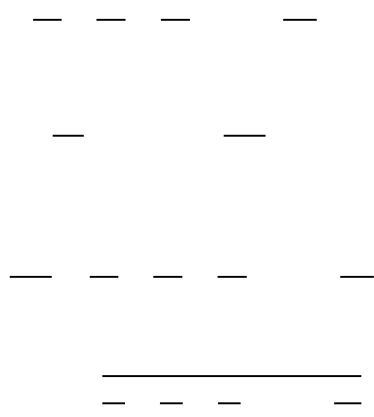

Where,

Thus,

The equivalent inductance of parallel inductors is the reciprocal of the sum of the reciprocals of the individual inductances.

* Note that the inductors in parallel are combined in the same way as resistors in parallel.

CAPACITIVE NETWORKS

We know from resistive circuits and inductive circuits that the series-parallel combination is a powerful tool for reducing circuits. This technique can be extended to series-parallel connections of capacitors, which are sometimes encountered. We desire to replace these capacitors by a single equivalent capacitor C_{eq} .

SERIES CAPACITORS

Two or more capacitors are said to be in series, if the same current flows through all of them. Consider a series connection of N capacitors, as shown in Fig. 1.24(a), with the equivalent circuit shown in Fig. 1.24(b). The capacitors have the same current through them.

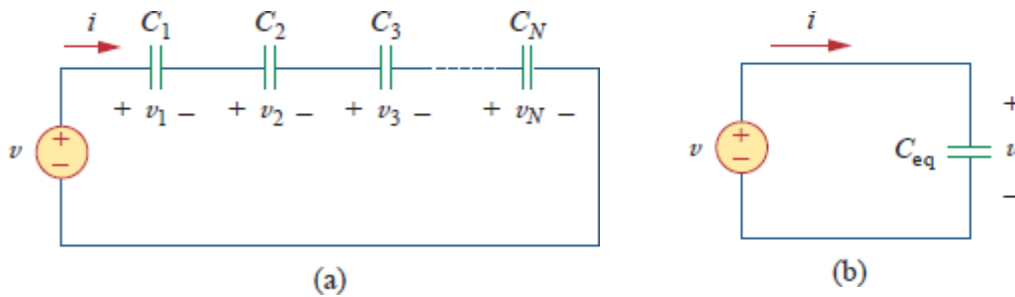

Fig. 1.24 (a) series connection of N capacitors (b) Equivalent circuit for the series capacitors

Applying KVL to the loop,

We know that the voltage across a capacitor is

$$v = \frac{1}{C} \int i dt + v_0$$

If we neglect the initial value of voltage i.e, then voltage across the capacitor becomes

$$v = \frac{1}{C} \int i dt$$

Hence, Eq. (1) becomes

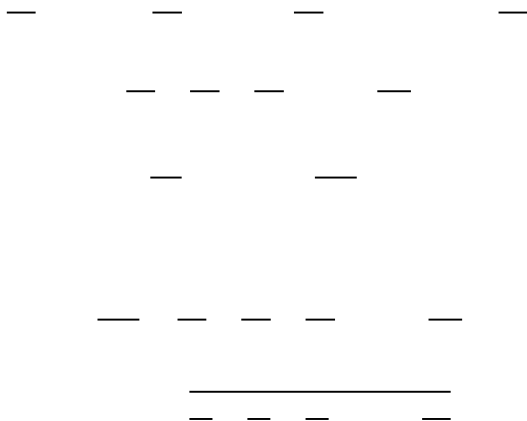

Where,

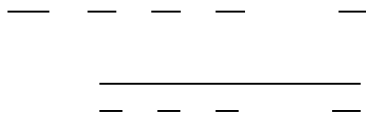

Thus,

The equivalent capacitance of series-connected capacitors is the reciprocal of the sum of the reciprocals of the individual capacitances.

* Note that the capacitors in series are combined in the same way as resistors in parallel.

For $N=2$,

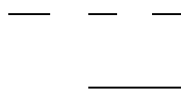

PARALLEL CAPACITORS

Two or more capacitors are said to be in parallel, if the same voltage appears across each element. Consider a parallel connection of N capacitors, as shown in Fig. 1.25(a), with the equivalent circuit in Fig. 1.25(b). The capacitors have the same voltage across them.

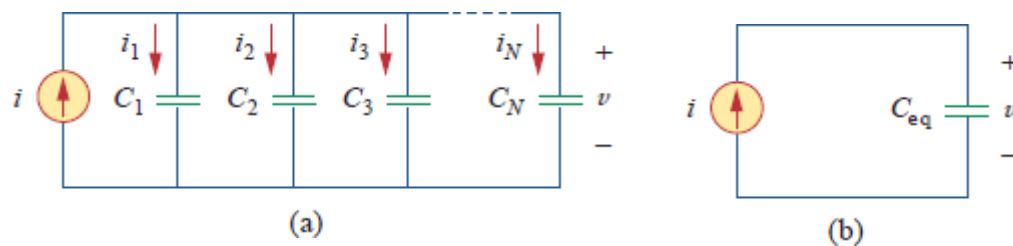

Fig. 1.25 (a) Parallel connection of N capacitors (b) Equivalent circuit for parallel capacitors

Applying KCL to Fig. 1.25(a)

We know that the current through capacitor is



Therefore, Eq. (1) becomes

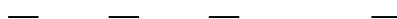

Where,

Thus

The equivalent capacitance of parallel-connected capacitors is the sum of the individual capacitances.

* Capacitors in parallel are combined in exactly the same way as resistors in series.

INTRODUCTION TO MEASURING INSTRUMENTS

The measurement of a given quantity is the result of comparison between the quantity to be measured and a definite standard. The instruments which are used for such measurements are called **measuring instruments**. The three basic quantities in the electrical measurement are current, voltage and power. The measurement of these quantities is important as it is used for obtaining measurement of some other quantity or used to test the performance of some electronic circuits or components etc.

The necessary requirements for any measuring instruments are:

1. With the introduction of the instrument in the circuit, the circuit conditions should not be altered. Thus the quantity to be measured should not get affected due to the instrument used.
2. The power consumed by the instruments for their operation should be as small as possible.

The instrument which measures the current flowing in the circuit is called ammeter while the instrument which measures the voltage across any two points of a circuit is called voltmeter. But there is no fundamental difference in the operating principle of analog voltmeter and ammeter. The action of almost all the analog ammeters and voltmeters depends on the deflecting torque produced by an electric current. In ammeters such a torque is proportional to the current to be measured. In voltmeters this torque is decided by a current which is proportional to the voltage to be measured. Thus all the analog ammeters and voltmeters are basically current measuring devices. The instruments which are used to measure the power are called power meters or wattmeters.

CLASSIFICATIONS OF ELECTRICAL INSTRUMENTS

Electrical instruments are broadly classified into two types

1) Absolute instruments

Absolute instruments are those which give the value of the quantity to be measured in terms of the constants of the instrument and their detection only. No previous calibration or comparison is necessary in their case. The example of such an instrument is tangent galvanometer, which gives the value of current, in terms of the tangent of deflection produced by the current, the radius and number of turns of wire used and the horizontal component of earth's field.

2) Secondary instruments

Secondary instruments are those, in which the value of electrical quantity to be measured can be determined from the deflection of the instruments, only when they have been pre-calibrated by comparison with an absolute instrument. Without calibration, the deflection of such instruments is

meaningless. Secondary instruments are most generally used in everyday work; the use of the absolute instruments being merely confined within laboratories, as standardizing instruments.

The secondary instruments are again divided into the following three types

- a) Indicating instruments
- b) Recording instruments
- c) Integrating instruments

a) Indicating instruments:

Indicating instruments are those which indicate the instantaneous value of the electrical quantity being measured at the time at which it is being measured. Their indications are given by pointers moving over calibrated dials. Ordinary ammeters, voltmeters and wattmeters belong to this class.

b) Recording instruments:

These instruments give a continuous record of the given electrical quantity which is being measured over a specific period. The examples are various types of recorders. In such recording instruments, the readings are recorded by drawing the graph. The pointer of such instruments is provided with a marker i.e. pen or pencil, which moves on graph paper as per the reading. The X-Y plotter is the best example of such an instrument.

c) Integrating instruments:

These instruments measure the total quantity of electricity delivered over period of time. For example a household energy meter registers number of revolutions made by the disc to give the total energy delivered, with the help of counting mechanism consisting of dials and pointers.

ESSENTIAL REQUIREMENTS OF AN INSTRUMENT

In case of measuring instruments, the effect of unknown quantity is converted into a mechanical force which is transmitted to the pointer which moves over a calibrated scale. The moving system of such instrument is mounted on a pivoted spindle. For satisfactory operation of any indicating instrument, following systems must be present in an instrument.

- 1) Deflecting system producing deflecting torque T_d
- 2) Controlling system producing controlling torque T_c
- 3) Damping system producing damping torque

Let us see the various ways in which these torques are obtained in an indicating instrument.

DEFLECTING SYSTEM:

In most of the indicating instruments the mechanical force proportional to the quantity to be measured is generated. This force or torque deflects the pointer. The system which produces such a deflecting torque is called deflecting system and the torque is denoted as T_d .

The deflecting system uses one of the following effects produced by current or voltage, to produce deflecting torque.

- a) **Magnetic Effect:** When a current carrying conductor is placed in uniform magnetic field, it experiences a force which causes to move it. This effect is mostly used in many instruments like moving iron attraction and repulsion type, permanent magnet moving coil instruments etc
- b) **Thermal Effect:** The current to be measured is passed through a small element which heats it to cause rise in temperature which is converted to an e.m.f. by a thermocouple attached to it. When two dissimilar metals are connected end to end to form a closed loop and the two junctions formed are maintained at different temperatures, then e.m.f. is induced which causes the flow of current through the closed circuit which is called a thermocouple.

- c) **Electrostatic Effect:** When two plates are charged, there is a force exerted between them, which move one of the plates. This effect is used in electrostatic instruments which are normally voltmeters.
- d) **Induction Effect:** When a non-magnetic conducting disc is placed in a magnetic field produced by electromagnets which are excited by alternating currents, an e.m.f. is induced in it. If a closed path is provided, there is a flow of current in the disc. The interaction between induced currents and the alternating magnetic fields exerts a force on the disc which causes to move it. This interaction is called an induction effect. This principle is mainly used in energy meters.
- e) **Hall Effect:** If a bar of semiconducting material is placed in uniform magnetic field and if the bar carries current, then an e.m.f. is produced between two edges of conductor. The magnitude of this e.m.f. depends on flux density of magnetic field, current passing through the conducting bar and Hall Effect co-efficient which is constant for a given semiconductor. This effect is mainly used in flux-meters.

Thus the deflecting system provides the deflecting torque or operating torque for movement of pointer from its zero position. It acts as the prime mover for the deflection of pointer.

CONTROLLING SYSTEM

This system should provide a force so that current or any other electrical quantity will produce deflection of the pointer proportional to its magnitude. The important functions of this system are,

- 1) It produces a force equal and opposite to the deflecting force in order to make the deflection of pointer at a definite magnitude. If this system is absent, then the pointer will swing beyond its final steady position for the given magnitude and deflection will become indefinite.
- 2) It brings the moving system back to zero position when the force which causes the movement of the moving system is removed. It will never come back to its zero position in the absence of controlling system.

The controlling torque in indicating instruments may be provide by one of the following two methods.

- 1) By weighting of moving parts i.e., Gravity Control
- 2) By one or more springs i.e., Spring Control

1) GRAVITY CONTROL

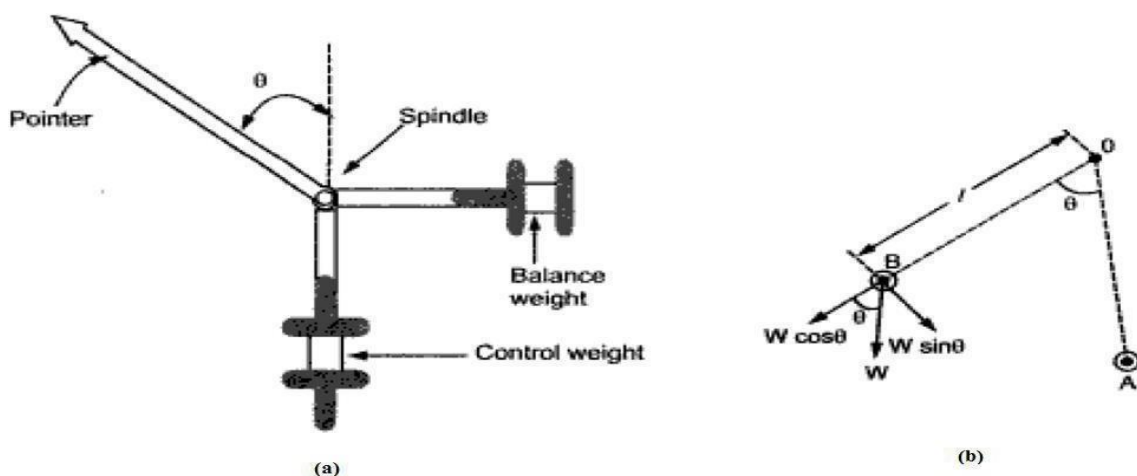

Fig. 1.29 Gravity Control

This type of control consists of a small weight attached to the moving system whose position is adjustable. This weight produces a controlling torque due to gravity. This weight is called control weight. The Figs. 1.29(a) shows the gravity control system. At the zero position of the pointer, the controlling torque is zero. This position is shown as position A of the weight in the Fig. 1.29(b). If the system deflects, the weight position also changes, as shown in the Fig.1.29(b).

The system deflects through an angle θ . The control weight acts at a distance from the center.

The component $W \sin \theta$ of this weight we try to restore the pointer back to the zero position.

This is nothing but the controlling torque T_c .

Thus,

Here

Generally all meters are current sensing meters, where deflecting torque is proportional to current. i.e.,

Where $K = \text{constant}$

In equilibrium position,

Thus the deflection is proportional to current i.e. quantity to be measured. But as it is a function of, the scale for the instrument using gravity control is not uniform.

Advantages:

- 1) Its performance is not time dependent.
- 2) It is simple and cheap.
- 3) The controlling torque can be varied by adjusting the position of the control weight.
- 4) Its performance is not temperature dependent.

Disadvantages:

- 1) The scale is non-uniform causing problems to record accurate readings.
- 2) The system must be used in vertical position only and must be properly levelled. Otherwise it may cause serious errors in the measurement.
- 3) As delicate and proper leveling required, in general it is not used for indicating instruments and portable instruments.

2) SPRING CONTROL

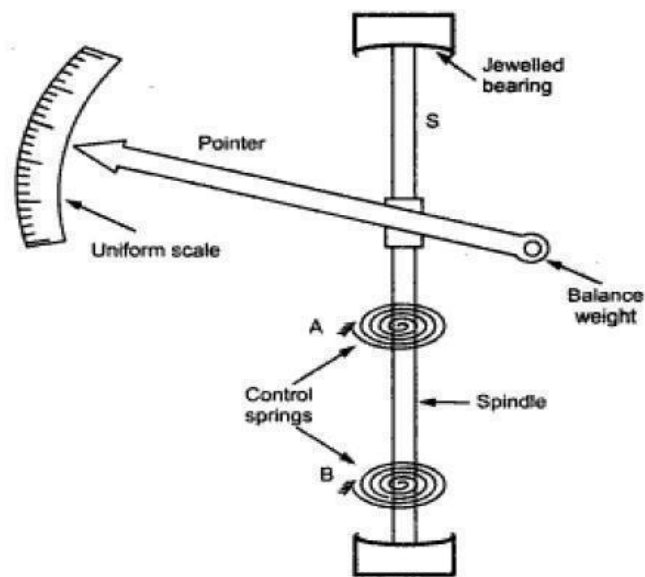

Fig. 1.30 Spring Control

Two hair springs are attached to the moving system which exerts controlling torque. To employ spring control to an instrument, following requirements are essential.

- 1) The spring should be non-magnetic.
- 2) The spring should be free from mechanical stress.
- 3) The spring should have a small resistance, sufficient cross-sectional area.
- 4) It should have low resistance temperature co-efficient.

The arrangement of the springs is shown in the Fig. 1.30. The springs are made up of non-magnetic materials like silicon bronze, hard rolled silver or copper, platinum silver and german silver. For most of the instruments, phosphor bronze spiral springs are provided. Flat spiral springs are used in almost all indicating instruments. The inner end of the spring is attached to the spindle while the outer end is attached to a lever or arm which is actuated by a set of screw mounted at the front of the instrument. So zero setting can be easily done.

The controlling torque provided by the instrument is directly proportional to the angular deflection of the pointer.

Now, deflecting torque is proportional to current

At equilibrium

Thus the deflection is proportional to the current. Hence the scale of the instrument using spring control is uniform. When the current is removed, due to spring force the pointer comes back to initial position. The spring control is very popular and is used in almost all indicating instruments.

DAMPING SYSTEM

The deflecting torque provides some deflection and controlling torque acts in the opposite direction to that of deflecting torque. So before coming to the rest, pointer always oscillates due to inertia, about the equilibrium position. Unless pointer rests, final reading cannot be obtained. So to bring the pointer to rest within short time, damping system is required. The system should provide a damping torque only when the moving system is in motion. Damping torque is proportional to velocity of the moving system but it does not depend on operating current. It must not affect controlling torque or increase the friction.

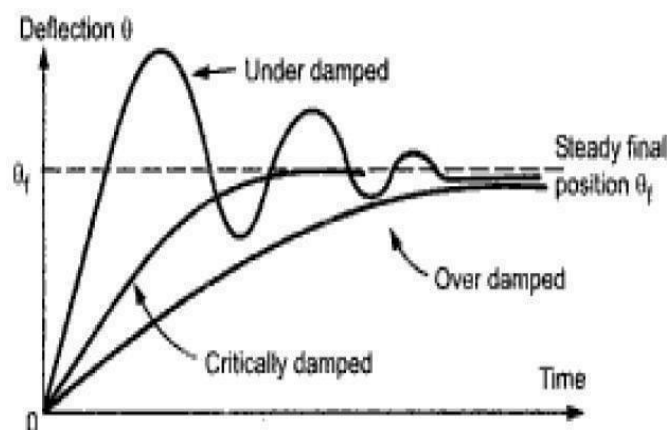

Fig 1.31 time response of damping system

The quickness with which over damped the moving system settles to the final steady position Time depends on relative damping. If the moving system reaches to its final position rapidly.

but smoothly without oscillations, the instrument is said to be critically damped. If the instrument is under damped, the moving system will oscillate about the final steady position with decreasing amplitude and will take some time to come to rest. The instrument is said to be over damped, if the moving system moves slowly to its final steady position. In over damped case the response of the system is very slow and sluggish. In practice slightly under damped systems are preferred. The time response of damping system for various types of damping conditions is shown in the Fig. 1.31.

The following methods are used to produce damping torque.

- 1) Air friction damping
- 2) Fluid friction r damping
- 3) Eddy current damping.

1) AIR FRICTION DAMPING

This arrangement consists of a light aluminium piston which is attached to the moving system, as shown in the Fig. 1.32.

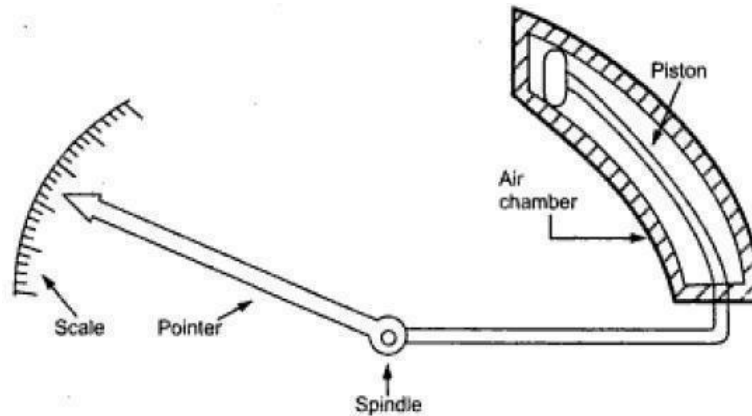

Fig. 1.32 Air friction damping

The piston moves in a fixed air chamber. It is close to one end. The clearance between piston and wall chambers is uniform and small. The piston reciprocates in the chamber when there are oscillations. When piston moves into the chamber, air inside is compressed and pressure of air developed due to friction opposes the motion of pointer. There is also opposition to motion of moving system when piston moves out of the chamber. Thus the oscillations and the overshoot gets reduced due to and fro motion of the piston in the chamber, providing necessary damping torque. This helps in settling down the pointer to its final steady position very quickly.

2) FLUID FRICTION DAMPING

Fluid friction damping may be used in some instruments. The method is similar to air friction damping, only air is replaced by working fluid. The friction between the disc and fluid is used for opposing motion. Damping force due to fluid is greater than that of air due to more viscosity. The disc is also called vane.

The arrangement is shown in the Fig. 1.33. It consists of a vane attached to the spindle which is completely dipped in the oil. The frictional force between oil and the vane is used to produce the damping torque, which opposes the oscillating behavior of the pointer.

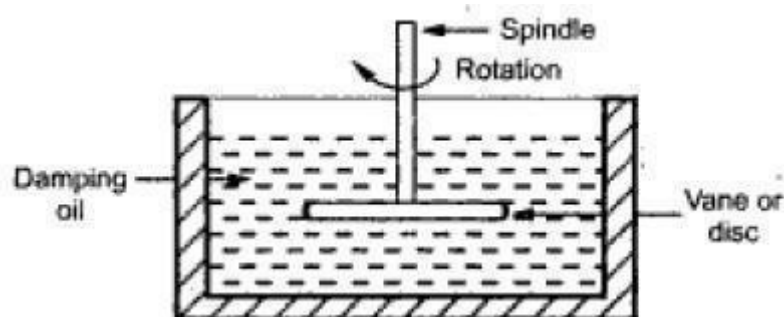

Fig 1.33 Fluid friction damping

Advantages:

- I. Due to more viscosity of fluid, more damping is provided.
- J. The oil can also be used for insulation purposes.
- K. Due to up thrust of oil, the load on the bearings is reduced, thus reducing the frictional errors.

Disadvantage

- 1. This can be only used for the instruments which are in vertical "position.
- 2. Due to oil leakage, the instruments cannot be kept clean.

3) EDDY CURRENT DAMPING

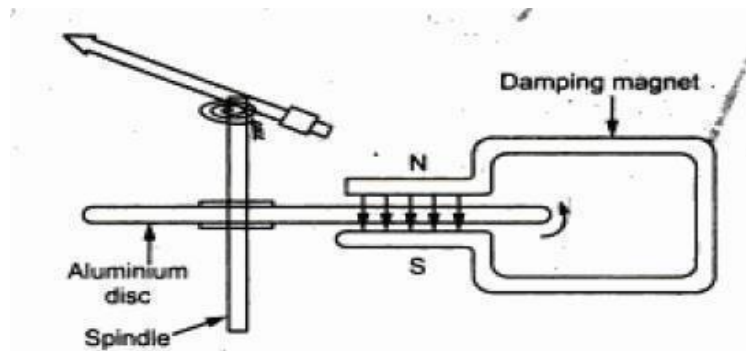

Fig. 1.34 Eddy current damping

This is the most effective way of providing damping. It is based on the Faraday's law and Lenz's law. When a conductor moves in a magnetic field cutting the flux, e.m.f. gets induced in it and the direction of this e.m.f. is so as to oppose the cause producing it.

In this method, an 'aluminium disc is connected to the spindle. The arrangement of disc is such that when it rotates, it cuts the magnetic flux lines of a permanent magnet. The arrangement is shown in the Fig. 1.34. When the pointer oscillates, aluminium disc rotates under the influence of magnetic field of damping magnet. So disc cuts the flux which causes an induced e.m.f. in the disc. The disc is a closed path hence induced e.m.f. circulates current through the disc called eddy current. The direction of such eddy current is so as oppose the cause producing it. The cause is relative motion between disc and field. Thus it produces an opposing torque so as to reduce the oscillations of pointer. This brings pointer to rest quickly. This is most effective and efficient method of damping.

PERMANENT MAGNET MOVING COIL (PMMC) INSTRUMENT

Principle:

When a current carrying coil is placed in the magnetic field produced by permanent magnet, the coil experiences a force and moves. The amount of force experienced by the coil is proportional to the current passing through the coil.

Construction:

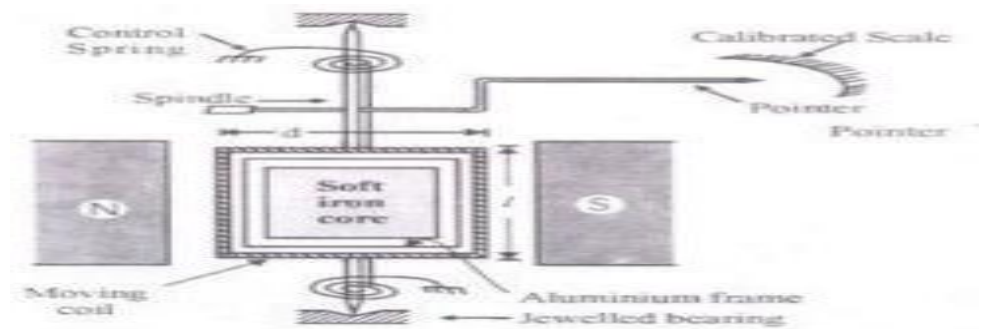

Fig. 1.35 PMMC instrument

The construction of PMMC instrument is as shown in the Fig. 1.35. It consists of a moving coil which is either rectangular or circular in shape. It has number of turns of fine wire. The coil is suspended so that it is free to turn about its vertical axis. The coil is placed in uniform, horizontal and radial magnetic field of a permanent magnet in the shape of a horse-shoe. As the coil is moving and the magnet is permanent, the instrument is called permanent magnet moving coil instrument. The controlling torque is provided by two phosphor bronze hair springs. The damping torque is provided by eddy current damping. It is obtained by movement of the aluminium former, moving in the magnetic field of the permanent magnet. The pointer is carried by the spindle and it moves over a graduated scale. The pointer has light weight so that it can deflect rapidly. The mirror is placed below the pointer to get the accurate reading by removing the parallax error. The scale markings of the basic PMMC instruments are usually linearly spaced as the deflecting torque and hence the pointer deflection is directly proportional to the current passing through the coil.

Operation:

Whenever the PMMC instrument is connected in the electric circuit to measure the current or voltage, current flows through the moving coil. As the current carrying coil is placed in the magnetic field produced by the permanent magnet, a mechanical force acts on the coil. As the coil is attached to the moving system the pointer moves in a clockwise direction over a graduated scale to indicate the value of current or voltage being measured. Therefore, the mechanical force is responsible for producing the deflecting torque in the clockwise direction. The two hair springs provided in the spindle will generate the necessary controlling torque. When the controlling torque equals to the deflecting torque the pointer comes to the rest and indicate the current through the coil. The damping torque is provided by the eddy current damping, it is obtained by the movement of the aluminium former moving in the magnetic field of permanent magnet.

If we reverse the direction of current through the coil, then the pointer tends to rotate in anti clockwise direction. But a stopper or observer is provided to protect the pointer tends to rotate in the anticlockwise direction. The resultant deflecting torque in the coil for AC input current is zero. Hence the PMMC meter cannot measure AC quantities and measure DC only.

TORQUE EQUATION OF PMMC

When the current of I ampere flows through the coil, the coil experiences a force of F Newton which is given by

$$F = NBIL \text{ newton}$$

Deflecting torque

$$T_d = F * \text{Perpendicular Distance (d)}$$

$$= NBII*d$$

$$= NBIA$$

Where N = Number of turns of the coil

B = Flux density in air gap (wb/m²)

A = Effective coil area (m²)

I = Current flowing in moving coil

(A) Td= Deflecting torque (N-m)

For a given instrument N, B and A are constant, thus

$$Td \propto I$$

$$Td = K I$$

Since spring control has been used,

$$Tc \propto \theta$$

$$Tc = Kc \theta$$

Under equilibrium conditions,

$$Td = Tc$$

$$K I = Kc \theta$$

$$\theta = (K/Kc) I$$

Therefore,

$$\theta \propto I$$

Thus the deflection of the pointer is directly proportional to the current passing through the coil.

Advantages:

1. The scale is uniformly divided as the current is directly proportional to deflection of the pointer. Hence it is very easy to measure the quantities from the instruments.
2. Power consumption is also very low.
3. The torque to weight ratio is high
4. The sensitivity is high
5. Extension of instrument range is possible
6. The eddy currents induced in the metallic former on which coil is wound, provide effective damping.

Disadvantages:

1. Suitable for only D.C. measurements.

2. The cost is high due to delicate construction and accurate machining.
3. Ageing of permanent magnet and control springs introduces the errors.

ERRORS IN PMMC INSTRUMENT:

The basic sources of errors in PMMC instruments are friction, temperature and aging of various parts. To reduce the frictional errors ratio of torque to weight is made very high.

The most serious errors are produced by the heat generated or by changes in the temperature. This changes the resistance of the working coil, causing large errors. In case of voltmeters, a large series resistance of very low temperature coefficient is used. This reduces the temperature errors.

The aging of permanent magnet and control springs also cause errors. The weakening of magnet and springs cause opposite errors. The weakening of magnet cause less deflection while weakening of the control springs cause large deflection, for a particular value of current. The proper use of material and pre-ageing during manufacturing can reduce the errors due to weakening of the control springs.

MOVING IRON (MI) INSTRUMENT

Moving iron type instruments are of mainly two types.

1. Moving Iron Attraction Type Instrument
2. Moving Iron Repulsion Type Instrument.

1) MOVING IRON ATTRACTION TYPE INSTRUMENT

Principle:

The basic working principle of these instruments is very simple that a soft iron piece if brought near the magnet gets attracted by the magnet.

Construction:

The construction of the attraction type instrument is shown in the Fig. 1.36. It consists of a fixed coil C and moving iron piece D. The coil is flat and has a narrow slot like opening. The moving iron is a flat disc which is eccentrically mounted on the spindle. The spindle is supported between the jewel bearings. The spindle carries a pointer which moves over a graduated scale. The numbers of turns of the fixed coil are dependent on the range of the instrument. For passing large current through the coil only few turns are required

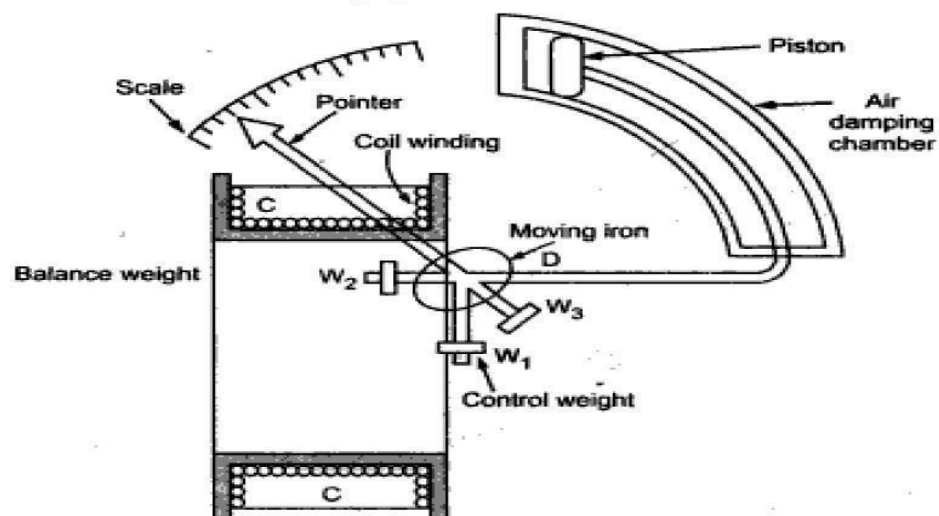

Fig. 1.36 Moving Iron Attraction Type Instrument

The controlling torque is provided by the springs but gravity control may also be used for vertically mounted panel type instruments. The damping torque is provided by the air friction. A light aluminium piston is attached to the moving system. It moves in a fixed chamber. The chamber is closed at one end. It can also be provided with the help of vane attached to the moving system. The operating magnetic field in moving iron instruments is very weak. Hence eddy current damping is not used since it requires a permanent magnet which would affect or distort the operating field.

Operation:

When the instrument is connected in a circuit to measure the current, then the fixed coil develops a magnetic field. The coil behaves like a magnet and attracts the moving iron piece towards it. As an moving iron piece is attached to the moving system, the pointer moves over a graduated scale.

If the current in the coil is reversed, direction of magnetic field produced is also reverse and attracts the iron piece toward the centre of the coil and the pointer moves. Hence the moving iron instrument can be used to measure both DC and AC quantities.

2) MOVING IRON REPULSION TYPE INSTRUMENT

Principle:

Two iron pieces are kept with close proximity in a magnetic field get magnetized with the same polarity. Hence a repulsive force is developed. If one of the two iron pieces is made movable, the repulsive force will act on it and move it one side. This movement is used to measure voltage or current which produces the field.

Construction:

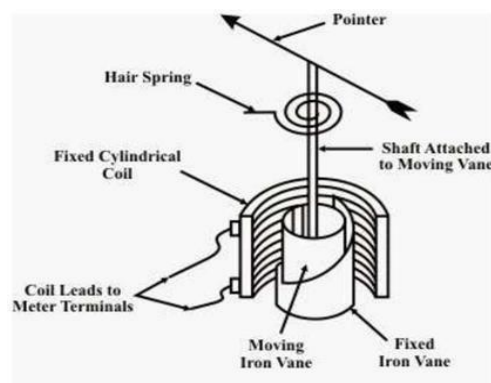

Fig. 1.37 Moving Iron Repulsive Type Instrument

The construction of the attraction type instrument is shown in the Fig. 1.37. It consists of a fixed hollow cylindrical coil which carries the operating current. Two iron pieces (iron vanes) are available inside the coil, one iron piece is fixed and the other is movable. The fixed iron piece is attached to the coil,

while the moving iron piece is attached to the moving system. When the moving iron is repulsed from the fixed iron piece the pointer moves over a graduated scale.

Operation:

When the voltage is applied to the coil the magnetic field will be developed inside the coil. Then the two iron pieces are magnetized with same polarity. Due to the same polarity in between them, the moving iron piece get repulsive from the fixed iron piece. As the pointer is attached to the moving iron, with the movement of the moving iron the pointer also moves and show the reading. Here the controlling torque is provided by the spring control or gravity control and damping torque is provided by the air friction damping.

TORQUE EQUATION OF MOVING IRON INSTRUMENT

Then the deflection torque produced due to the current flowing through the coil is given by,

Where I = Current through the coil

L = Inductance of the coil

θ = angular deflection

dL = change in inductance

$d\theta$ = change in angular deflection

The controlling torque provide by the spring control is

Where k is spring constant

Under equilibrium condition,

Hence, the deflection of the moving iron instrument is directly proportional to the square of the current flowing through the coil.

ADVANTAGES AND DISADVANTAGES OF MOVING IRON INSTRUMENTS

Advantages:

- 1) These instruments can be used to measure the both DC and AC quantities.
- 2) These are less expensive, robust and simple in construction.
- 3) These instruments have high operating torque.
- 4) These instruments have the high torque to weight ratio, hence frictional error is very less.

Disadvantages:

- 1) Scale of these instruments is non-uniform.
- 2) Power consumption is higher for low voltage ratings.
- 3) There are serious errors due to hysteresis, frequency changes and stray magnetic fields.
- 4) These instruments are less sensitive than PMMC instruments.

ERRORS IN MOVING IRON INSTRUMENT:

The various errors in the moving iron instruments are,

- 1) **Hysteresis error:** Due to hysteresis effect, the flux density for the same current while ascending and descending values is different. While descending, the flux density is higher and while ascending it is lesser. So meter reads higher for descending values of current or voltage. So remedy for this is to use smaller iron parts which can demagnetize quickly or to work with lower flux densities

2) Temperature error: The temperature error arises due to the effect of temperature on the temperature coefficient of the spring. This error is of the order of 0.02% per °C change in temperature. Errors can cause due to self heating of the coil and due to which change in resistance of the coil. So coil and series resistance must have low temperature coefficient. Hence manganin is generally used for the series resistances.

3) Stray magnetic field error: The operating magnetic field in case of moving iron instruments is very low. Hence effect of external i.e. stray magnetic field can cause error. This effect depends on the direction of the stray magnetic field with respect to the operating field of the instrument.

4) Frequency error: These are related to a.c. operation of the instrument. The change in frequency affects the reactance of the working coil and also affects the magnitude of the eddy currents. This causes errors in the instrument.

5) Eddy current error: When instrument is used for a.c. measurements the eddy currents are produced in the iron parts of the instrument. The eddy current affects the instrument current causing the change in the deflecting torque. This produces the error in the meter reading. As eddy currents are frequency dependent, frequency changes cause eddy current error.

UNIT II

DC MACHINES

Introduction

Converters that are used to continuously translate electrical input to mechanical output or vice versa are called electric machines. The process of translation is known as electromechanical energy conversion. An electric machine is therefore a link between an electrical system and a mechanical system. In these machines the conversion is reversible. If the conversion is from mechanical to electrical energy, the machine is said to act as a **generator**. If the conversion is from electrical to mechanical energy, the machine is said to act as a **motor**. In these machines, conversion of energy from electrical to mechanical form or vice versa results from the following two electromagnetic phenomena:

- When a conductor moves in a magnetic field, voltage is induced in the conductor. (**Generator action**)
- When a current carrying conductor is placed in a magnetic field, the conductor experiences a mechanical force. (**Motoraction**)

These two effects occur simultaneously whenever energy conversion takes place from electrical to mechanical or vice versa. In motoring action, the electrical system makes current flow through conductors that are placed in the magnetic field. A force is produced on each conductor. If the conductors are placed on a structure free to rotate, an electromagnetic torque will be produced, tending to make the rotating structure rotate at some speed. If the conductors rotate in a magnetic field, a voltage will also be induced in each conductor. In generating action, the process is reversed. In this case, the rotating structure, the rotor, is driven by a prime mover (such as a steam turbine or a diesel engine). A voltage will be induced in the conductors that are rotating with the rotor. If an electrical load is connected to the winding formed by these conductors, a current i will flow, delivering electrical power to the load. Moreover, the current flowing through the conductor will interact with the magnetic field to produce a reaction torque, which will tend to oppose the torque applied by the prime mover.

Construction of a DC Machine:

A DC generator can be used as a DC motor without any constructional changes and vice versa is also possible. Thus, a DC generator or a DC motor can be broadly termed as a DC machine. These basic constructional details are also valid for the construction of a DC motor. Hence, let's call this point as construction of a DC machine instead of just 'construction of a dc generator'.

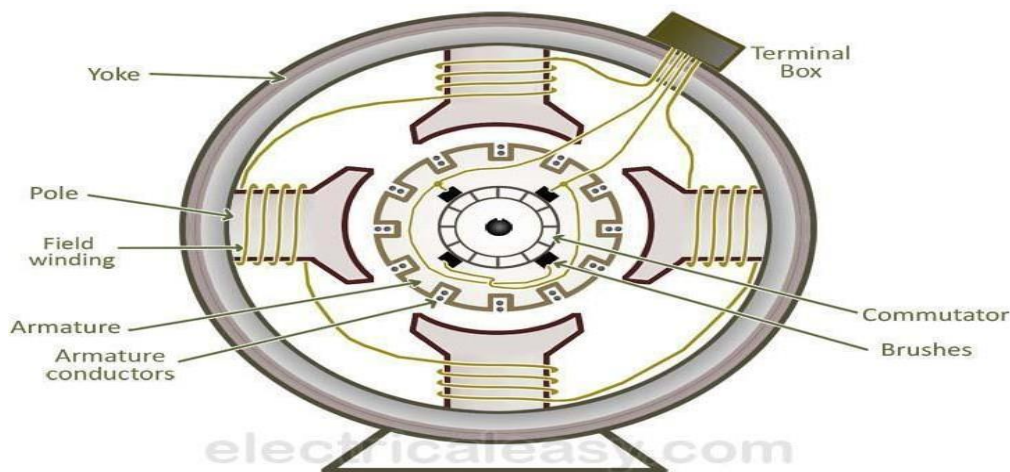

Figure 2.1 DC Machine construction

The above figure shows the constructional details of a simple 4-pole DC machine. A DC machine consists of two basic parts; stator and rotor. Basic constructional parts of a DC machine are described below.

1. **Yoke:** The outer frame of a dc machine is called as yoke. It is made up of cast iron or steel. It not only provides mechanical strength to the whole assembly but also carries the magnetic flux produced by the field winding.
2. **Poles and pole shoes:** Poles are joined to the yoke with the help of bolts or welding. They carry field winding and pole shoes are fastened to them. Pole shoes serve two purposes; (i) they support field coils and (ii) spread out the flux in air gap uniformly.
3. **Field winding:** They are usually made of copper. Field coils are former wound and placed on each pole and are connected in series. They are wound in such a way that, when energized, they form alternate North and South poles.



Figure 2.2 Armature core (rotor)

4. **Armature core:** Armature core is the rotor of the machine. It is cylindrical in shape with slots to carry armature winding. The armature is built up of thin laminated circular steel disks for reducing eddy current losses. It may be provided with air ducts for the axial air flow for cooling purposes. Armature is keyed to the shaft.
5. **Armature winding:** It is usually a former wound copper coil which rests in armature slots. The armature conductors are insulated from each other and also from the armature core. Armature winding can be wound by one of the two methods; lap winding or wave winding. Double layer lap or wave windings are generally used. A double layer winding means that each armature slot will carry two different coils.
6. **Commutator and brushes:** Physical connection to the armature winding is made through a commutator-brush arrangement. The function of a commutator, in a dc generator, is to collect the current generated in armature conductors. Whereas, in case of a dc motor, commutator helps in providing current to the armature conductors. A commutator consists of a set of copper segments which are insulated from each other. The number of segments is equal to the number of armature coils. Each segment is connected to an armature coil and the commutator is keyed to the shaft. Brushes are usually made from carbon or graphite. They rest on commutator segments and slide on the segments when the commutator rotates keeping the physical contact to collect or supply the current



Figure 2.3 Commutator **2.3 Classifications of DC Machines: (DC Motors and DC Generators)**

Each DC machine can act as a generator or a motor. Hence, this classification is valid for both: DC generators and DC motors. DC machines are usually classified on the basis of their field excitation method. This makes two broad categories of dc machines; (i) Separately excited and (ii) Self-excited.

- **Separately excited:** In separately excited dc machines, the field winding is supplied from a separate power source. That means the field winding is electrically separated from the armature circuit. Separately excited DC generators are not commonly used because they are relatively expensive due to the requirement of an additional power source or circuitry. They are used in laboratories for research work, for accurate speed control of DC motors with Ward-Leonard system and in few other applications where self-excited DC generators are unsatisfactory. In this type, the stator field flux may also be provided with the help of permanent magnets (such as in the case of a permanent magnet DC motors). A PMDC motor may be used in a small toy car.
- **Self-excited:** In this type, field winding and armature winding are interconnected in various ways to achieve a wide range of performance characteristics (for example, field winding in series or parallel with the armature winding). In self-excited type of DC generator, the field winding is energized by the current produced by themselves. A small amount of flux is always present in the poles due to the residual magnetism. So, initially, current induces in the armature conductors of a dc generator only due to the residual magnetism. The field flux gradually increases as the induced current starts flowing through the field winding.

Self-excited machines can be further classified as –

- **Series wound** – In this type, field winding is connected in series with the armature winding. Therefore, the field winding carries whole load current (armature current). That is why series winding is designed with few turns of thick wire and the resistance is kept very low (about 0.5 Ohm).
- **Shunt wound** – Here, field winding is connected in parallel with the armature winding. Hence, the full voltage is applied across the field winding. Shunt winding is made with a large number of turns and the resistance is kept very high (about 100 Ohm). It takes only small current which is less than 5% of the rated armature current.
- **Compound wound** – In this type, there are two sets of field winding. One is connected in series and the other is connected in parallel with the armature winding. Compound wound machines are further divided as -
 - **Short shunt** – field winding is connected in parallel with only the armature winding

- **Long shunt** – field winding is connected in parallel with the combination of series field winding and armature winding

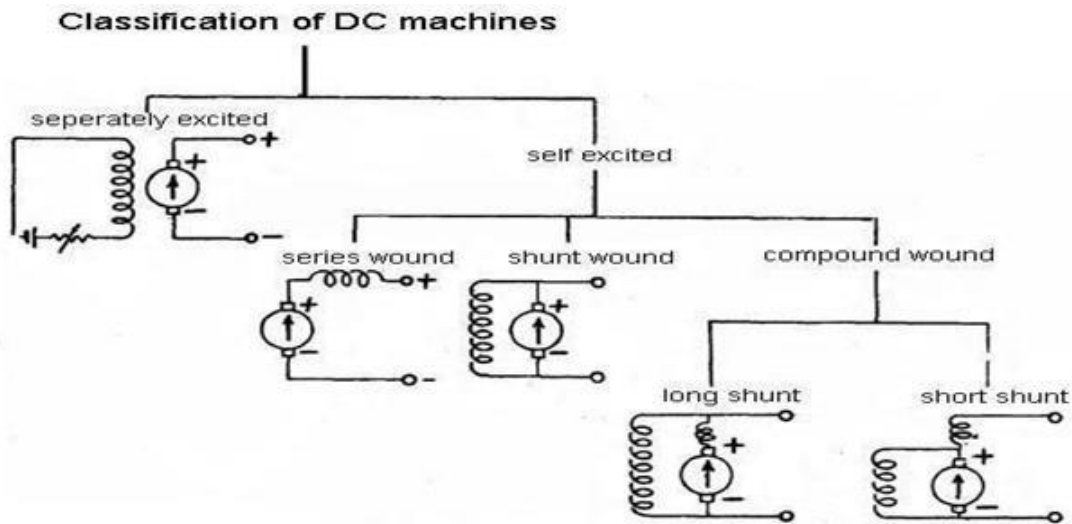

Figure 2.4 Classifications of DC Machines

DC GENERATOR

Working Principle of A DC Generator:

According to Faraday's laws of electromagnetic induction, whenever a conductor is placed in a varying magnetic field (OR a conductor is moved in a magnetic field), an emf (electromotive force) gets induced in the conductor. The magnitude of induced emf can be calculated from the emf equation of dc generator. If the conductor is provided with the closed path, the induced current will circulate within the path. In a DC generator, field coils produce an electromagnetic field and the armature conductors are rotated into the field. Thus, an electromagnetically induced emf is generated in the armature conductors. The direction of induced current is given by Fleming's right hand rule.

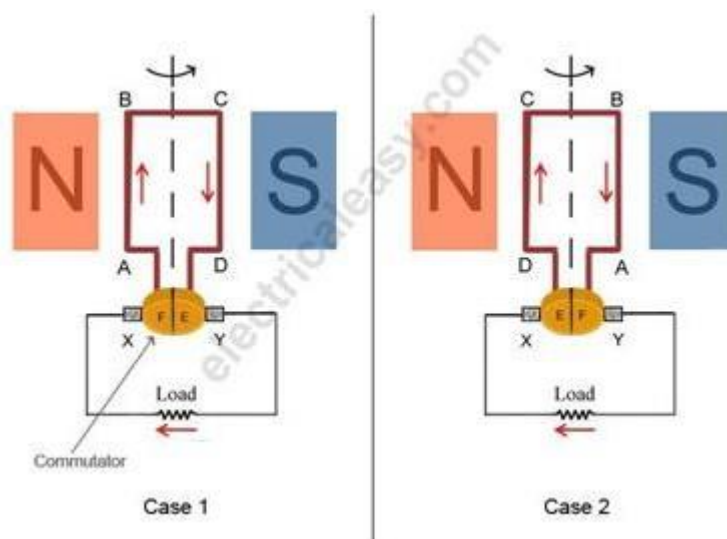

Figure 2.5 Principle of DC generator

According to Fleming's right hand rule, the direction of induced current changes whenever the direction of motion of the conductor changes. Let's consider an armature rotating clockwise and a conductor at the left is moving upward. When the armature completes a half rotation, the direction of motion of that particular conductor will be reversed to downward. Hence, the direction of current in every armature conductor will be alternating. If you look at the above figure, you will know how the direction of the induced current is alternating in an armature conductor. But with a split ring commutator, connections of the armature.

conductors also gets reversed when the current reversal occurs. And therefore, we get unidirectional current at the terminals.

EMF Equation of A DC Generator

Consider a DC generator with the following parameters,

P = number of field poles

Φ = flux produced per pole in Wb (weber)

Z = total no. of armature conductors

A = no. of parallel paths in armature

N = rotational speed of armature in revolutions per min. (rpm)

Now,

▪ Average emf generated per conductor is given by $d\Phi/dt$ (Volts) ... eq. 1 ▪ Flux cut by one conductor in one revolution = $d\Phi = P\Phi$ (Weber),

▪ Number of revolutions per second (speed in RPS) = $N/60$ ▪
Therefore, time for one revolution = $dt = 60/N$ (Seconds)

▪ From eq. 1, emf generated per conductor = $d\Phi/dt = P\Phi N/60$ (Volts)(eq. 2)

Above equation-2 gives the emf generated in one conductor of the generator. The conductors are connected in series per parallel path, and the emf across the generator terminals is equal to the generated emf across any parallel path.

Therefore, $E_g = P\Phi NZ / 60A$

For simplex lap winding, number of parallel paths is equal to the number of poles (i.e. $A=P$),
Therefore, for simplex lap wound dc generator, $E_g = P\Phi NZ / 60P$

For simplex wave winding, number of parallel paths is equal to 2 (i.e $P=2$),
Therefore, for simplex wave wound dc generator, $E_g = P\Phi NZ / 120$

Types of DC Generators:

DC generators can be classified in two main categories, viz; (i) Separately excited and (ii) Self-excited.

(i) Separately excited: In this type, field coils are energized from an independent external DC source.

(ii) Selfexcited: In this type, field coils are energized from the current produced by the generator itself. Initial emf generation is due to residual magnetism in field poles. The generated emf causes a part of current to flow in the field coils, thus strengthening the field flux and thereby increasing emf generation. Self excited dc generators can further be divided into three types

Characteristics of DC Generators

Generally, following three characteristics of DC generators are taken into considerations: (i) Open Circuit Characteristic (O.C.C.), (ii) Internal or Total Characteristic and (iii) External Characteristic. These characteristics of DC generators are explained below.

Open Circuit Characteristic (O.C.C.) (E_0/I_f)

Open circuit characteristic is also known as magnetic characteristic or no-load saturation characteristic. This characteristic shows the relation between generated emf at no load (E_0) and the field current (I_f) at a given fixed speed. The O.C.C. curve is just the magnetization curve and it is practically similar for all type of generators. The data for O.C.C. curve is obtained by operating the generator at no load and keeping a constant speed. Field current is gradually increased and the corresponding terminal voltage is recorded. The connection arrangement to obtain O.C.C. curve is as shown in the figure below. For shunt or series excited generators, the field winding is disconnected from the machine and connected across an external supply.

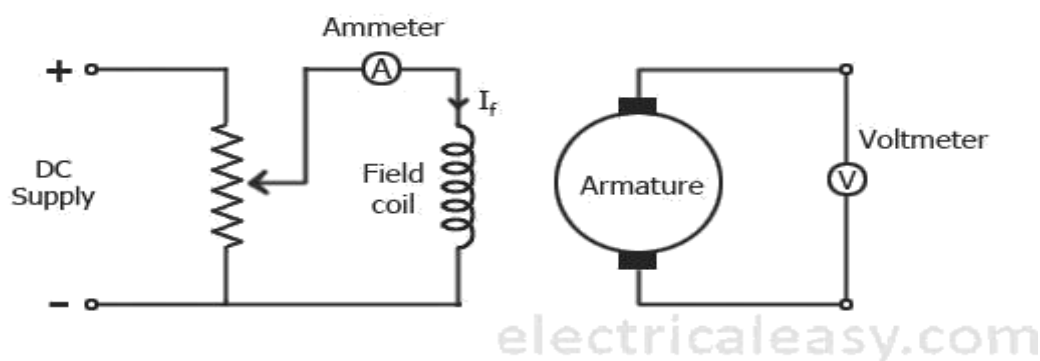
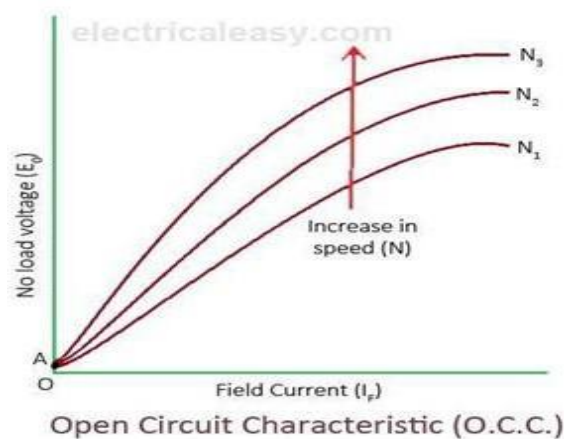

Figure 2. 6 OCC characteristics of DC generator

Now, from the emf equation of dc generator, we know that $E_g = k\phi$. Hence, the generated emf should be directly proportional to field flux (and hence, also directly proportional to the field current). However, even when the field current is zero, some amount of emf is generated (represented by OA in the figure below). This initially induced emf is due to the fact that there exists some residual magnetism in the field poles. Due to the residual magnetism, a small initial emf is induced in the armature. This initially induced emf aids the existing residual flux, and hence, increasing the overall field flux. This consequently increases the induced emf. Thus, O.C.C. follows a straight line. However, as the flux density increases, the

poles get saturated and the ϕ becomes practically constant. Thus, even we increase the I_f further, ϕ remains constant and hence, E_g also remains constant. Hence, the O.C.C. curve looks like the B-H characteristic.



The above figure shows a typical no-load saturation curve or open circuit characteristics for all types of DC generators.

Internal Or Total Characteristic (E/I_a)

An internal characteristic curve shows the relation between the on-load generated emf (E_g) and the armature current (I_a). The on-load generated emf E_g is always less than E₀ due to the armature reaction. E_g can be determined by subtracting the drop due to demagnetizing effect of armature reaction from no-load voltage E₀. Therefore, internal characteristic curve lies below the O.C.C. curve.

External Characteristic (V/I_L)

An external characteristic curve shows the relation between terminal voltage (V) and the load current (I_L). Terminal voltage V is less than the generated emf E_g due to voltage drop in the armature circuit. Therefore, external characteristic curve lies below the internal characteristic curve. External characteristics are very important to determine the suitability of a generator for a given purpose. Therefore, this type of characteristic is sometimes also called as **performance characteristic** or **load characteristic**.

Internal and external characteristic curves are shown below for each type of generator.

Characteristics of Separately Excited DC Generator

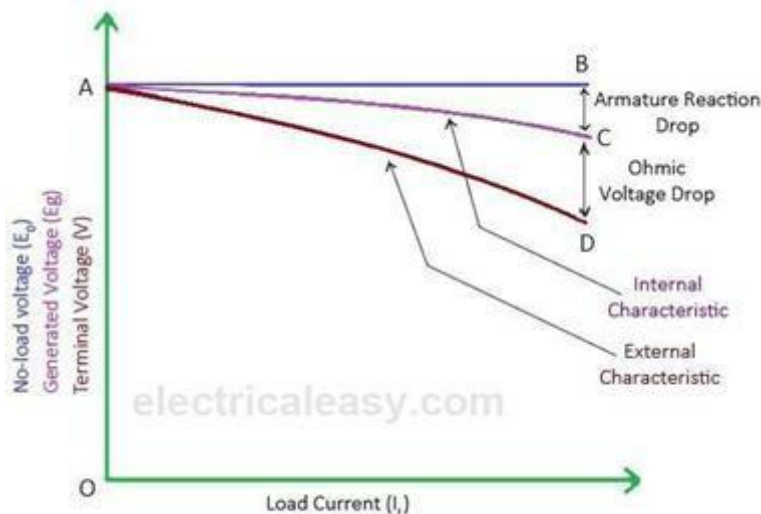

Characteristics of separately excited DC generator

If there is no armature reaction and armature voltage drop, the voltage will remain constant for any load current. Thus, the straight line AB in above figure represents the no-load voltage vs. load current I_L. Due to the demagnetizing effect of armature reaction, the on-load generated emf is less than the no-load voltage. The curve AC represents the on-load generated emf E_g vs. load current I_L i.e. internal characteristic (as I_a = I_L for a separately excited dc generator). Also, the terminal voltage is lesser due to ohmic drop occurring in the armature and brushes. The curve AD represents the terminal voltage vs. load current i.e. external characteristic.

Characteristics of DC Shunt Generator

To determine the internal and external load characteristics of a DC shunt generator the machine is allowed to build up its voltage before applying any external load. To build up voltage of a shunt generator, the generator is driven at the rated speed by a prime mover. Initial voltage is induced due to residual magnetism in the field poles. The generator builds up its voltage as explained by the

O.C.C. curve. When the generator has built up the voltage, it is gradually loaded with resistive load and readings are taken at suitable intervals. Connection arrangement is as shown in the figure below.

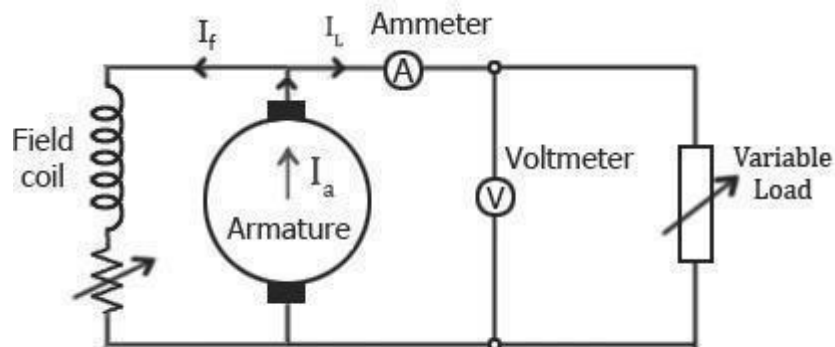

Unlike, separately excited DC generator, here, $I_L \neq I_a$. For a shunt generator, $I_a = I_L + I_f$. Hence, the internal characteristic can be easily transmitted to E_g vs. I_L by subtracting the correct value of I_f from I_a . During a normal running condition, when load resistance is decreased, the load current increases. But, as we go on decreasing the load resistance, terminal voltage also falls. So, load resistance can be decreased up to a certain limit, after which the terminal voltage drastically decreases due to excessive armature reaction at very high armature current and increased I^2R losses. Hence, beyond this limit any further decrease in load resistance results in decreasing load current. Consequently, the external characteristic curve turns back as shown by dotted line in the above figure.

Characteristics of DC Series Generator

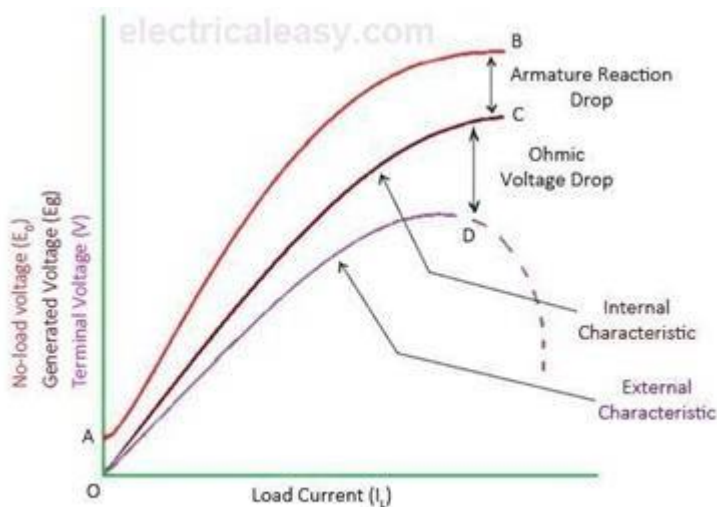

Characteristics of DC series generator

The curve AB in above figure identical to open circuit characteristic (O.C.C.) curve. This is because in DC series generators field winding is connected in series with armature and load. Hence, here load current is similar to field current (i.e. $I_L = I_f$). The curve OC and OD

represent internal and external characteristic respectively. In a DC series generator, terminal voltage increases with the load current. This is because, as the load current increases, field current also increases. However, beyond a certain limit, terminal voltage starts decreasing with increase in load. This is due to excessive demagnetizing effects of the armature reaction.

Characteristics of DC Compound Generator

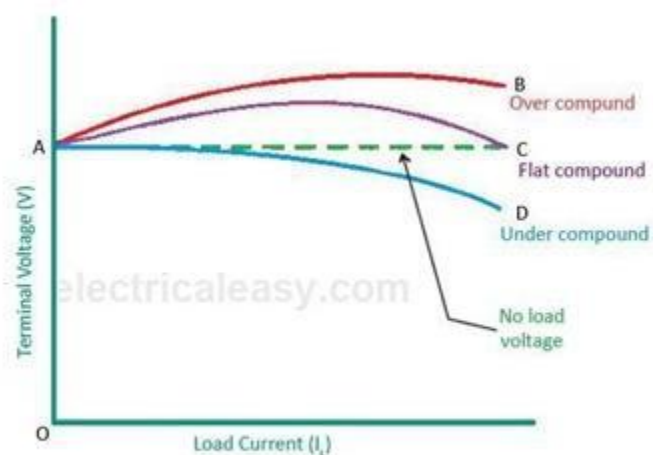

External characteristic of DC compound generator

The above figure shows the external characteristics of DC compound generators. If series winding amp-turns are adjusted so that, increase in load current causes increase in terminal voltage then the generator is called to be over compounded. The external characteristic for over compounded generator is shown by the curve AB in above figure.

If series winding amp-turns are adjusted so that, the terminal voltage remains constant even the load current is increased, then the generator is called to be flat compounded. The external characteristic for a flat compounded generator is shown by the curve AC.

If the series winding has lesser number of turns than that would be required to be flat compounded, then the generator is called to be under compounded. The external characteristics for an under compounded generator are shown by the curve AD.

DC MOTOR

A same DC machine can be used as a motor or generator. **Construction of a DC motor** is same as that of a DC generator.

Working Principle of A DC Motor

A motor is an electrical machine which converts electrical energy into mechanical energy. The **principle of working of a DC motor** is that "whenever a current carrying conductor is placed in a magnetic field, it experiences a mechanical force". The direction of this force is given by Fleming's left hand rule and it's magnitude is given by $F = BIL$. Where, B = magnetic flux density, I = current and L = length of the conductor within the magnetic field.

Fleming's left hand rule: If we stretch the first finger, second finger and thumb of our left hand to be perpendicular to each other AND direction of magnetic field is represented by the first finger,

direction of the current is represented by second finger then the thumb represents the direction of the

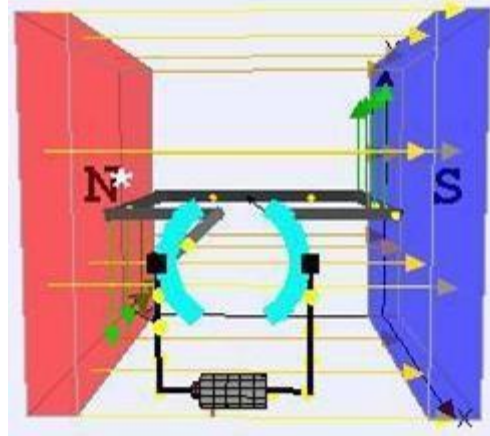

force experienced by the current carrying conductor.

Working of DC Motor

When armature windings are connected to a DC supply, current sets up in the winding. Magnetic field may be provided by field winding (electromagnetism) or by using permanent magnets. In this case, current carrying armature conductors experience force due to the magnetic field, according to the principle stated above.

Commutator is made segmented to achieve unidirectional torque. Otherwise, the direction of force would have reversed every time when the direction of movement of conductor is reversed the magnetic field.

Back EMF

According to fundamental laws of nature, no energy conversion is possible until there is something to oppose the conversion. In case of generators this opposition is provided by magnetic drag, but in case of dc motors there is back emf.

When the armature of the motor is rotating, the conductors are also cutting the magnetic flux lines and hence according to the Faraday's law of electromagnetic induction, an emf induces in the armature conductors. The direction of this induced emf is such that it opposes the armature current (I_a). The circuit diagram below illustrates the **direction of the back emf** and armature current. Magnitude of **Back emf** can be given by the emf equation of DC generator.

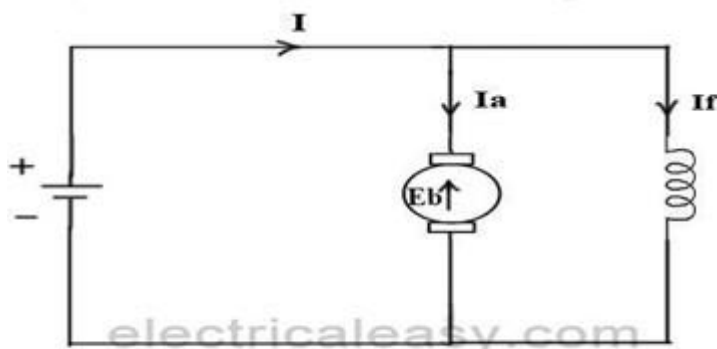

Significance Of Back Emf:

Magnitude of back emf is directly proportional to speed of the motor. Consider the load on a dc motor is suddenly reduced. In this case, required torque will be small as compared to the current torque. Speed of the motor will start increasing due to the excess torque. Hence, being proportional to the speed, magnitude of the back emf will also increase. With increasing back emf armature current will start decreasing. Torque being proportional to the armature current, it will also decrease until it becomes sufficient for the load. Thus, speed of the motor will regulate.

On the other hand, if a dc motor is suddenly loaded, the load will cause decrease in the speed. Due to decrease in speed, back emf will also decrease allowing more armature current. Increased armature current will increase the torque to satisfy the load requirement. Hence, presence of the back emf makes a dc motor 'self-regulating'.

Types of DC Motors

DC motors are usually classified on the basis of their excitation configuration, as follows - ▪
Separately excited (field winding is fed by external source)

- Self excited -
 - Series wound (field winding is connected in series with the armature)
 - Shunt wound (field winding is connected in parallel with the armature)
 - Compound wound -
 - Long shunt
 - Short shunt

Torque Equation of A DC Motor

When armature conductors of a DC motor carry current in the presence of stator field flux, a mechanical torque is developed between the armature and the stator. Torque is given by the product of the force and the radius at which this force acts.

- Torque $T = F \times r$ (N-m) ...where, F = force and r = radius of the armature
- Work done by this force in once revolution = Force \times distance = $F \times 2\pi r$
= circumference of the armature)
- Net power developed in the armature = work done / time

= (force \times circumference \times no. of revolutions) / time

= $(F \times 2\pi r \times N) / 60$ (Joules per second) eq. 2.1

But, $F \times r = T$ and $2\pi N/60 =$ angular velocity ω in radians per second. Putting these in the above equation 2.1

Net power developed in the armature = $P = T \times \omega$ (Joules per second)

Armature Torque (T_a)

- The power developed in the armature can be given as, $P_a = T_a \times \omega = T_a \times 2\pi N/60$

- The mechanical power developed in the armature is converted from the electrical power,
- We know, $E_b = P\Phi NZ / 60A$
- Therefore, $T_a \times 2\pi N/60 = (P\Phi NZ / 60A) \times I_a$
- Rearranging the above equation,

$$T_a = (PZ / 2\pi A) \times \Phi \cdot I_a \text{ (N-m)}$$

The term $(PZ / 2\pi A)$ is practically constant for a DC machine. Thus, armature torque is directly proportional to the product of the flux and the armature current i.e. $T_a \propto \Phi \cdot I_a$

Shaft Torque (Tsh)

Due to iron and friction losses in a dc machine, the total developed armature torque is not available at the shaft of the machine. Some torque is lost, and therefore, shaft torque is always less than the armature torque.

Shaft torque of a DC motor is given as,

$$T_{sh} = \text{output in watts} / (2\pi N/60) \dots (\text{where, } N \text{ is speed in RPM})$$

Characteristics of DC Motors

Generally, three characteristic curves are considered important for DC motors which are, (i) Torque vs. armature current, (ii) Speed vs. armature current and (iii) Speed vs. torque. These are explained below for each type of DC motor. These characteristics are determined by keeping the following two relations in mind.

$$T_a \propto \Phi \cdot I_a \text{ and}$$

$$N \propto E_b / \Phi$$

These above equations can be studied at - emf and torque equation of dc machine. For a DC motor, magnitude of the back emf is given by the same emf equation of a dc generator i.e. $E_b = P\Phi NZ / 60A$.

For a machine, P, Z and A are constant, therefore, $N \propto E_b / \Phi$

Characteristics of DC Series Motors

Torque Vs. Armature Current (T_a-I_a)

This characteristic is also known as **electrical characteristic**. We know that torque is directly proportional to the product of armature current and field flux, $T_a \propto \Phi \cdot I_a$. In DC series motors, field winding is connected in series with the armature, i.e. $I_a = I_f$. Therefore, before magnetic saturation of the field, flux Φ is directly proportional to I_a . Hence, before magnetic saturation $T_a \propto I_a^2$. Therefore, the T_a - I_a curve is parabola for smaller values of I_a .

After magnetic saturation of the field poles, flux Φ is independent of armature current I_a . Therefore, the torque varies proportionally to I_a only, $T \propto I_a$. Therefore, after magnetic saturation, T_a - I_a curve becomes a straight line.

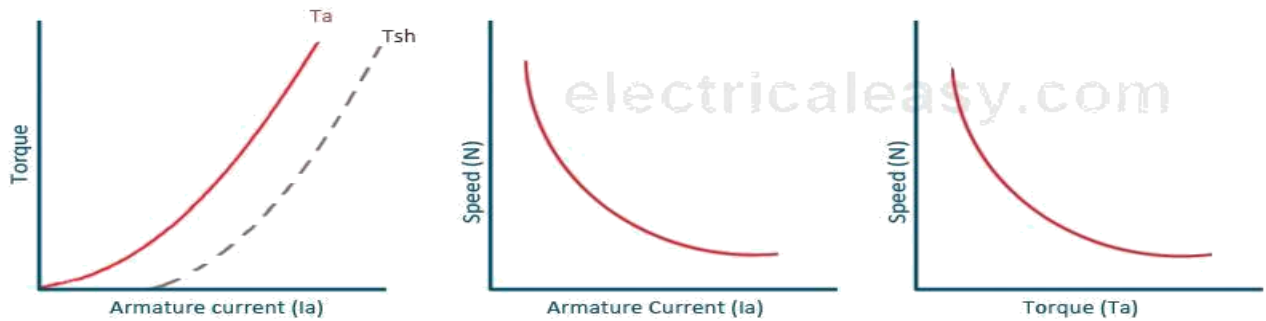

Characteristics of DC series motor

The shaft torque (T_{sh}) is less than armature torque (T_a) due to stray losses. Hence, the curve T_{sh} vs I_a lies slightly lower.

In DC series motors, (prior to magnetic saturation) torque increases as the square of armature current, these motors are used where high starting torque is required.

Speed Vs. Armature Current (N- I_a)

We know the relation, $N \propto E_b / \phi$

For small load current (and hence for small armature current) change in back emf E_b is small and it may be neglected. Hence, for small currents speed is inversely proportional to ϕ . As we know, flux is directly proportional to I_a , speed is inversely proportional to I_a . Therefore, when armature current is very small the speed becomes dangerously high. That is **why a series motor should never be started without some mechanical load**.

But, at heavy loads, armature current I_a is large. And hence, speed is low which results in decreased back emf E_b . Due to decreased E_b , more armature current is allowed.

Speed Vs. Torque (N- T_a)

This characteristic is also called as **mechanical characteristic**. From the above two **characteristics of DC series motor**, it can be found that when speed is high, torque is low and vice versa

Characteristics of DC Shunt Motors

Torque Vs. Armature Current (T_a - I_a)

In case of DC shunt motors, we can assume the field flux ϕ to be constant. Though at heavy loads, ϕ decreases in a small amount due to increased armature reaction. As we are neglecting the change in the flux ϕ , we can say that torque is proportional to armature current. Hence, the T_a - I_a characteristic for a dc shunt motor will be a straight line through the origin. Since heavy starting load needs heavy starting current, **shunt motor should never be started on a heavy load**.

Speed Vs. Armature Current (N- I_a)

As flux ϕ is assumed to be constant, we can say $N \propto E_b$. But, as back emf is also almost constant, the speed should remain constant. But practically, ϕ as well as E_b decreases with increase in load. Back emf E_b decreases slightly more than ϕ , therefore, the speed decreases slightly. Generally, the speed decreases only by 5 to 15% of full load speed. Therefore, **a shunt motor can be assumed as a constant speed motor**. In speed vs. armature current characteristic in the following figure, the straight horizontal line represents the ideal characteristic and the actual characteristic is shown by the dotted line.

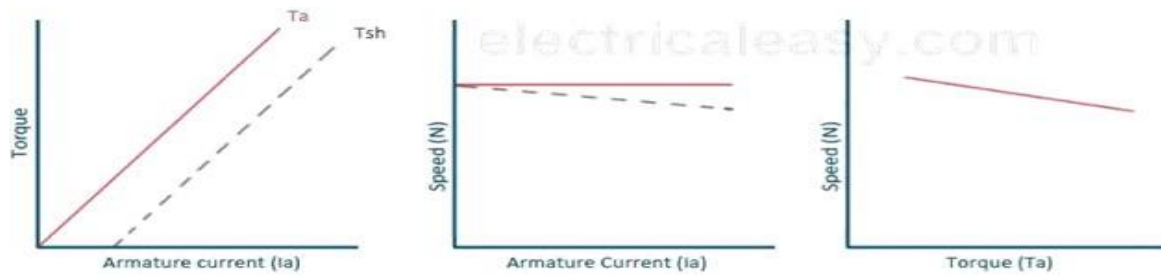

Characteristics of DC shunt motor

Characteristics of DC Compound Motor

DC compound motors have both series as well as shunt winding. In a compound motor, if series and shunt windings are connected such that series flux is in direction as that of the shunt flux then the motor is said to be cumulatively compounded. And if the series flux is opposite to the direction of the shunt flux, then the motor is said to be differentially compounded. Characteristics of both these compound motors are explained below.

(a) Cumulative compound motor

Cumulative compound motors are used where series characteristics are required but the load is likely to be removed completely. Series winding takes care of the heavy load, whereas the shunt winding prevents the motor from running at dangerously high speed when the load is suddenly removed. These motors have generally employed a flywheel, where sudden and temporary loads are applied like in rolling mills.

(b) Differential compound motor

Since in differential field motors, series flux opposes shunt flux, the total flux decreases with increase in load. Due to this, the speed remains almost constant or even it may increase slightly with increase in load ($N \propto E_b/\phi$). Differential compound motors are not commonly used, but they find limited applications in experimental and research work.

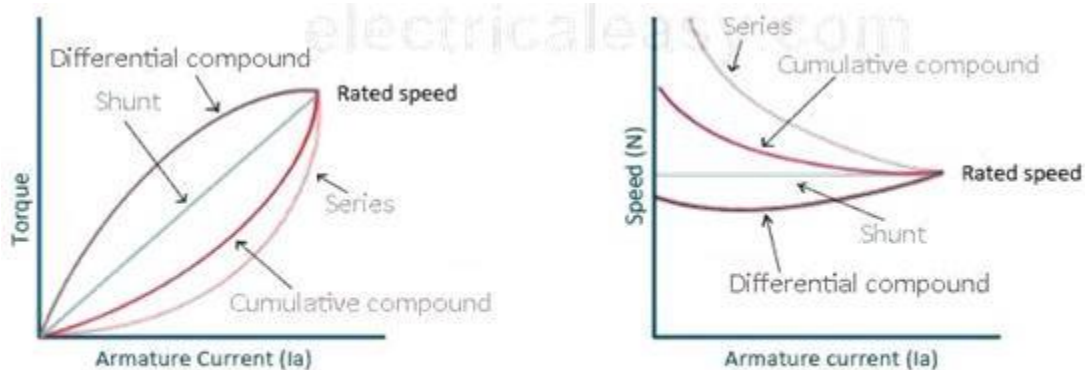

Characteristics of DC compound motor

Starting of A DC Motor

Basic operational voltage equation of a DC motor is given as $E = E_b + I_a R_a$ and hence $I_a = (E - E_b) / R_a$

Now, when the motor is at rest, obviously, there is no back emf E_b , hence armature current will be high at starting.

This excessive current will

1. blow out the fuses and may damage the armature winding and/or commutator brush arrangement.
2. produce very high starting torque (as torque is directly proportional to armature current), and this high starting torque will produce huge centrifugal force which may throw off the armature windings.

Thus to avoid above two drawbacks, starters are used for **starting of DC machine**.

Starting Methods of a DC Motor

Thus, to avoid the above dangers while **starting a DC motor**, it is necessary to limit the starting current. For that purpose, starters are used to start a DC motor. There are various starters like, 3 point starter, 4 point starter, No load release coil starter, thyristor starter etc. The main concept behind every **DC motor starter** is, adding external resistance to the armature winding at starting.

a) 3 Point Starter

The internal wiring of a **3 point starter** is as shown in the figure.

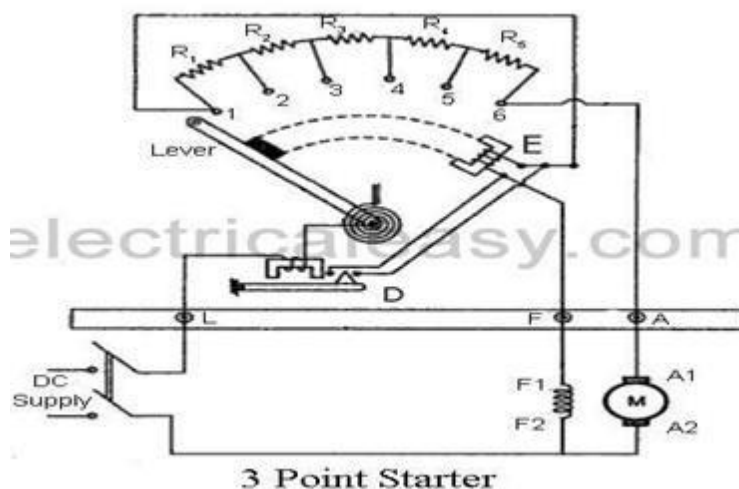

When motor is to be started, the lever is turned gradually to the right. When lever touches point 1, the field winding gets directly connected across the supply, and the armature winding gets connected with resistances R_1 to R_5 in series. Hence at starting full resistance is added in series with armature. Then as the lever is moved further, the resistance is gradually is cut out from the armature circuit. Now, as the lever reaches to position 6, all the resistance is cut out from the armature circuit and armature gets directly connected across the supply. The electromagnet E (no voltage coil) holds the lever at this position. This electromagnet releases the lever when there is no (or low) supply voltage. When the motor is overloaded beyond a predefined value, overcurrent release electromagnet D gets activated, which short circuits electromagnet E, and hence releases the lever and motor is turned off.

b) 4 Point Starter:

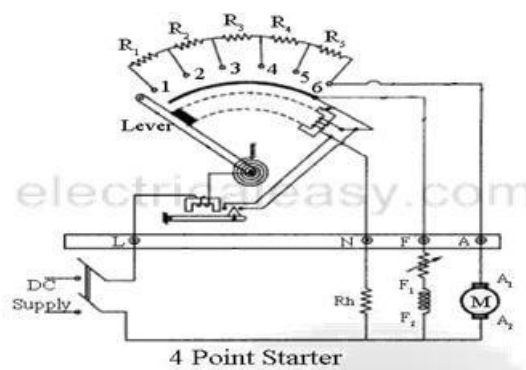

The main **difference between a 3 point starter and a 4 point starter** is that the no voltage coil is not connected in series with field coil. The field gets directly connected to the supply, as the lever moves touching the brass arc. The no voltage coil (or Hold on coil) is connected with a current limiting resistance R_h . This arrangement ensures that any change of current in the shunt field does not affect the current through hold on coil at all. This means that electromagnet pull of the hold-on coil will always be sufficient so that the spring does not unnecessarily restore the lever to the off position.

This starter is used where field current is to be adjusted by means of a field rheostat.

c) DC series motor starter:

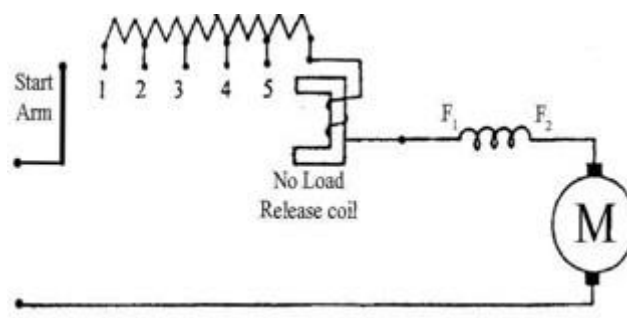

Construction of DC series motor starters is very basic as shown in the figure. A start arm is simply moved towards right to start the motor. Thus at first maximum resistance is connected in series with the armature and then gradually decreased as the start arm moves towards right.

The no load release coil holds the start arm to the run position and leaves it at no load.

Losses in A DC Generator and DC Motor

A dc generator converts mechanical power into electrical power and a dc motor converts electrical power into mechanical power. Thus, for a dc generator, input power is in the form of mechanical and the output power is in the form of electrical. On the other hand, for a dc motor, input power is in the form of electrical and output power is in the form of mechanical. In a practical machine, whole of the input power cannot be converted into output power as some power is lost in the process. This causes the efficiency of the machine to be reduced. Efficiency is the ratio of output power to the input power. Thus, in order to design rotating dc machines with higher efficiency, it is important to study the losses occurring in them.

Various losses in a rotating DC machine (DC generator or DC motor) can be characterized as follows:

Copper losses
Armature Cu loss
Field Cu loss
Loss due to brush contact resistance
Iron Losses
Hysteresis loss
Eddy current loss
Mechanical losses
Friction loss
Windage loss

The above tree categorizes various types of losses that occur in a dc generator or a dc motor. Each of these is explained in details below.

a) Copper Losses

These losses occur in armature and field copper windings. **Copper losses** consist of Armature copper loss, Field copper loss and loss due to brush contact resistance.

Armature copper loss = $I_a^2 R_a$ (where, I_a = Armature current and R_a = Armature resistance)

This loss contributes about 30 to 40% to full load losses. The armature copper loss is variable and depends upon the amount of loading of the machine.

In the case of a shunt wounded field, field copper loss is practically constant. It contributes about 20 to 30% to full load losses.

Brush contact resistance also contributes to the copper losses. Generally, this loss is included into armature copper loss.

b) Iron Losses (Core Losses)

As the armature core is made of iron and it rotates in a magnetic field, a small current gets induced in the core itself too. Due to this current, eddy current loss and hysteresis loss occur in the armature iron core. Iron losses are also called as Core losses or magnetic losses.

Hysteresis loss is due to the reversal of magnetization of the armature core. When the core passes under one pair of poles, it undergoes one complete cycle of magnetic reversal. The frequency of magnetic reversal is given by, $f = P \cdot N / 120$ (where, P = no. of poles and N = Speed in rpm)

The loss depends upon the volume and grade of the iron, frequency of magnetic reversals and value of flux density. **Hysteresis loss** is given by, Steinmetz formula:

$h = \eta B_{max}^{1.6} f V$ (watts) where, η = Steinmetz hysteresis constant

V = volume of the core in m^3

Eddy current loss: When the armature core rotates in the magnetic field, an emf is also induced in the core (just like it induces in armature conductors), according to the Faraday's law of electromagnetic induction. Though this induced emf is small, it causes a large current to flow in the body due to the low resistance of the core. This current is known as eddy current. The power loss due to this current is known as eddy current loss.

c) Mechanical Losses

Mechanical losses consist of the losses due to friction in bearings and commutator. Air friction loss of rotating armature also contributes to these.

These losses are about 10 to 20% of full load losses.

Stray Losses

In addition to the losses stated above, there may be small losses present which are called as stray losses or miscellaneous losses. These losses are difficult to account. They are usually due to inaccuracies in the designing and modeling of the machine. Most of the times, stray losses are assumed to be 1% of the full load.

Power Flow Diagram

The most convenient method to understand these losses in a dc generator or a dc motor is using the power flow diagram. The diagram visualizes the amount of power that has been lost in various types of losses and the amount of power which has been actually converted into the output. Following are the typical power flow diagrams for a dc generator and a dc motor.

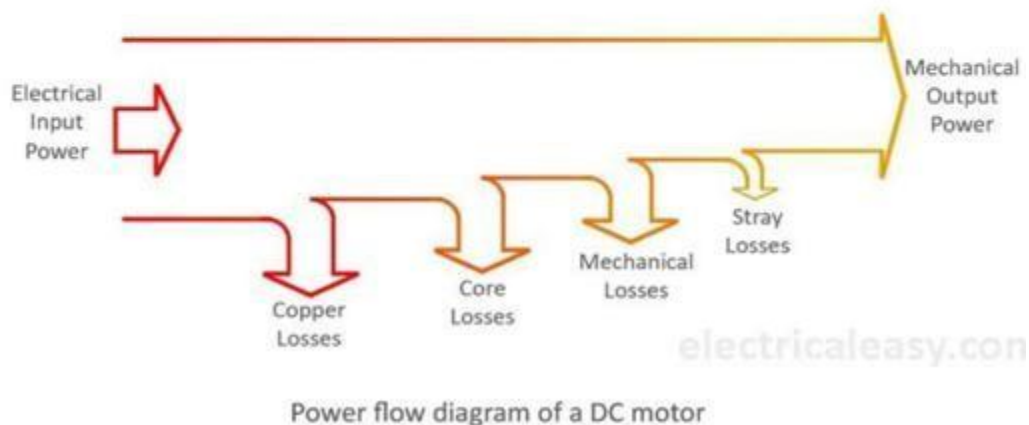
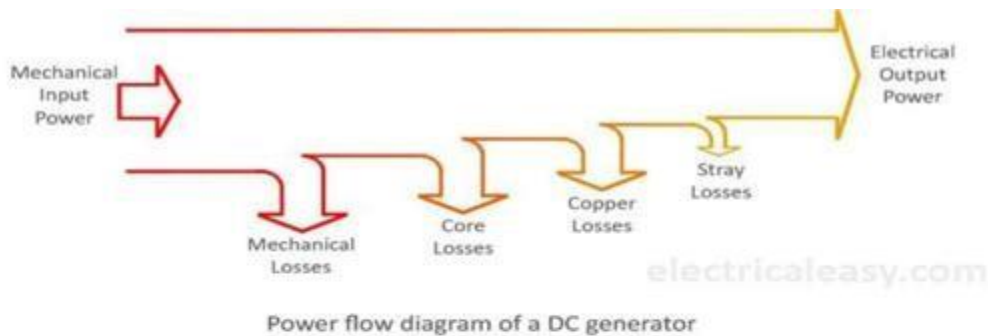

Applications of DC Motors

1. D.C. Shunt Motors:

It is a constant speed motor. Where the speed is required to remain almost constant from no load to full load. Where the load has to be driven at a number of speeds and any one of which is nearly constant.

- Industrial use:

- Lathes
- Drills
- Boring mills
- Shapers
- Spinning and weaving machines.

2. D.C. Series motor:

It is a variable speed motor. The speed is low at high torque and high at light or no load, the motor speed attains dangerously high speed. The motor has a high starting torque. (elevators, electric traction)

Industrial use:

- electric traction
- cranes
- elevators
- air compressor
- vacuum cleaner
- hair dryer
- sewing machine

3. D.C. Compound motor: Differential compound motors are rarely used because of its poor torque characteristics.

Industrial uses:

- Presses Shears
- Reciprocating machine

UNIT III ALTERNATING QUANTITIES AND AC MACHINES

INTRODUCTION:

The alternating quantity is one whose value varies with time. This alternating quantity may be periodic and non-periodic. Periodic quantity is one whose value will be repeated for every specified interval. Generally to represent alternating voltage or current we prefer sinusoidal wave form, because below listed properties

1. Derivative of sine is an sine function only.
2. Integral of sine is an sine function only.
3. It is easy to generate sine function using generators.
4. Most of the 2nd order system response is always sinusoidal.

Alternating quantity:

As said above an alternating voltage or current can be represented with sine wave. Sine wave can be defined with degree or radians as reference.

- At, 0 degrees --- 0
- 90 degrees --- maximum
- 180 degrees --- 0
- 270 degrees --- maximum
- 360 degrees --- 0

i.e value of sine function varies with time, firstly increases from zero and reaches maximum and again falls to zero, there after tends to increase in opposite direction and reaches maximum value and falls to zero. This the variation of sine in 1st cycle is called as positive half cycle and other negative half cycle.(i.e during +ve half cycle direction is required one and during 2nd half cycle direction actual required direction.). Therefore one positive and negative cycle combinly forms one complete cycle.

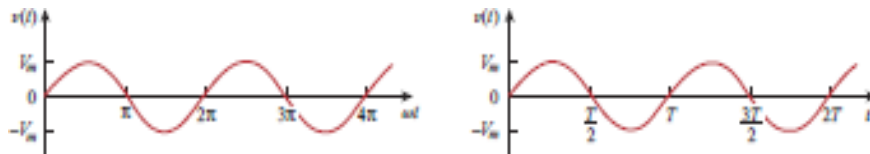

Sine equation , voltage , $V(t) = V_m \sin wt$.

Where, V_m = peak value or maximum value
 W = angular frequency.

Definitions:

Peak to peak value: It is total value from positive peak to the negative peak.($2V_m$)

Instantaneous value: It is the magnitude of wave form at any specified time. $V(t)$

Average value : It is ratio of area covered by wave form to its length.(V_d)

$$V_d = (1/T) \int V(t) dt$$

$$V_d = (1 / 2\pi) \int V_m \sin wt dt$$

$$= - V_m / 2\pi \cdot \cos wt \text{---with limits of } 2\pi \text{ and } 0$$

$$= 0. \text{ (i.e. average value of sine wave over a full cycle is zero)}$$

Hence it is defined for half cycle.

$$\begin{aligned} V_d &= (1 / \Pi) \int V_m \sin wt.dwt \\ &= - V_m / \Pi . \cos wt \text{ with limits of } \Pi \text{ and } 0 \\ &= 2V_m / \Pi \end{aligned}$$

RMS value:

It is the root mean square value of the function, which given as

$$\begin{aligned} V_{rms} &= (1/T) \int V(t)^2 dwt. \\ &= (1/2\Pi) \int V_m^2 [(1- \cos 2wt)/2]dwt. \\ &= (1/2\Pi) .V_m^2 [(wt- \sin 2wt / 2wt)/2] \\ &= V_m / \sqrt{2} = \text{effective value.} \end{aligned}$$

Peak factor:

It is the ratio of peak value to the rms value.

$$P_p = V_p / V_{rms} = \sqrt{2}$$

Form factor:

It is the ratio of average value to the rms value.

$$F_p = V_d / V_{rms} = 2 / \sqrt{\Pi} = 1.11$$

Eg: Find the peak, peak to peak, average, rms, peak factor and form factor of given current function ,
 $i(t) = 5 \sin wt$.

Phase and phase difference:

Phase of the sine indicates starting phase of the sine wave. i.e

Let , $V(t) = V_m \sin wt$, here we can say that phase is zero as function starts from origin.

$V(t) = V_m \sin(wt-\theta)$, here we can say that phase of function is θ degrees to right shift.

$V(t) = V_m \sin(wt+\theta)$, here we can say that phase of function is θ degrees to left shift.

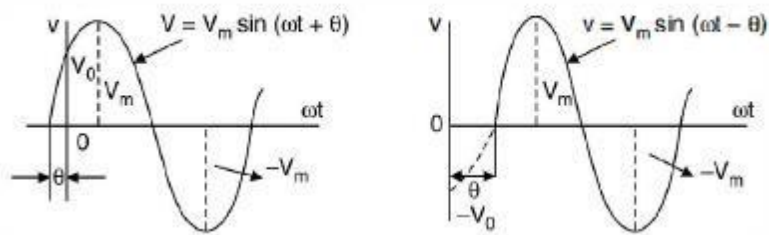

Phase difference is the difference of phase between two wave forms taking one as reference.

Eg: If wave form A is $V_m \sin (wt+15)$, B is $V_m \sin (wt - 30)$ and C is $V_m \sin (wt + 45)$.

Determine the phase difference between every pair if wave forms.

When A and B are compared , phase difference is 45 degrees.

When C and B are compared , phase difference is 75 degrees.

When A and C are compared , phase difference is 30 degrees.

Phasor diagram:

Phasor diagram is the pictorial representation of sine wave. Here magnitude and phase of the wave function are represented in four quadrant axis. We assume positive phases in anti-clock wise direction and negative phases in clock wise direction. From the phasor diagram we can easily identify the phase difference between different wave forms. We can also identify whether function is right shift or left shift.

Phase relations of network parameters:

Resistor:

Let us consider resistor allowing alternating current $i(t)$. Then the voltage drop across resistor is given as,

$$\begin{aligned}\text{If, } V(t) &= V_m \sin \omega t \\ V(t) &= i(t) \cdot R \\ i(t) &= V(t) / R \\ &= V_m \sin \omega t / R \\ i(t) &= I_m \sin \omega t.\end{aligned}$$

The ratio of $V(t) / i(t) = Z = \text{impedance offered by resistor. (ohms)}$.

$$\begin{aligned}Z &= V_m \sin \omega t / I_m \sin \omega t \\ &= V_m / I_m\end{aligned}$$

Hence we can say that $V(t)$ and $i(t)$ in resistor element are in phase.

Inductor:

Let us consider an coil of N turns allowing current $i(t)$. ($I_m \sin \omega t$)

Hence emf induced in the coil is ,

$$\begin{aligned}V(t) &= L di(t) / dt \\ &= L d(I_m \sin \omega t) / dt \\ &= L \omega I_m \cos \omega t \\ &= V_m \cos \omega t = V_m \sin(\omega t + 90).\end{aligned}$$

Where, $V_m = L \omega I_m = I_m \cdot X_L$

$X_L = \text{reactance offered by coil}$.

Impedance offered by coil is , $Z = V(t) / i(t)$
 $= V_m \sin(\omega t + 90) / I_m \sin \omega t$

The function $V_m \sin \omega t = V_m$.

$$\begin{aligned}Z &= V_m / I_m \\ Z &= V_m / I_m \\ &= j \omega L = j X_L \quad (j = 1 \angle 90^\circ)\end{aligned}$$

As there is left shift in $V(t)$, we can say that $i(t)$ lags $V(t)$ by 90 degrees.

Capacitor:

Let us consider an capacitor allowing current $i(t)$. ($I_m \sin \omega t$)

Hence voltage across it is ,

$$\begin{aligned}V(t) &= 1 / C \int i(t) dt \\ &= 1 / C \int I_m \sin \omega t dt \\ &= - \cos \omega t \cdot I_m / \omega C \\ &= V_m \sin(\omega t - 90).\end{aligned}$$

Where, $V_m = I_m / \omega C = I_m \cdot X_C$

$X_C = \text{reactance offered by capacitor}$

Impedance offered by capacitor is , $Z = V(t) / i(t)$
 $= V_m \sin(\omega t - 90) / I_m \sin \omega t$

The function $V_m \sin \omega t = V_m$.

$$\begin{aligned}Z &= V_m / I_m \\ Z &= V_m / I_m \\ &= -j \omega L = -j X_L \quad (j = 1 \angle 90^\circ)\end{aligned}$$

As there is right shift in $V(t)$, we can say that $i(t)$ leads $V(t)$ by 90 degrees.

Power in Ac circuits

In the case of DC circuits power is given as product of voltage and current in that element.

$$P = V \cdot I \text{ (W)}$$

$$\text{Let } V(t) = V_m \sin \omega t$$

$$i(t) = I_m \sin(\omega t + 90)$$

Instantaneous power, $P(t) = V(t) \cdot i(t)$

$$= V_m \sin \omega t \cdot I_m \sin(\omega t + \Phi)$$

$$= V_m I_m \sin \omega t \sin(\omega t + \Phi).$$

Average power, $P_{av} = \frac{1}{2\pi} \int p(t) d\omega t$.

$$= \frac{1}{2\pi} \int V_m I_m [\cos \Phi - \cos(2\omega t + \Phi)] d\omega t$$

As average value over full cycle is equal to zero, hence second term can be neglected.

$$P_{av} = \frac{1}{2\pi} \int V_m I_m [\cos \Phi] d\omega t$$

$$= V_{rms} I_{rms} \cos \Phi [\omega t] \text{ ----- with limits } 2\pi \text{ and } 2\pi$$

$$P_{av} = V_{rms} \cdot I_{rms} \cos \Phi \cdot (W) = \text{true power} = \text{active power}.$$

$\cos \Phi = P_{av} / V_{rms} \cdot I_{rms}$ = defined as power factor of the circuit.

$$\cos \Phi = P_{av} / P_a$$

$$= \text{true power} / \text{apparent power}$$

$$= \text{actual power utilized by load} / \text{total generated power}.$$

$$P_a = \text{apparent power} = V_{rms} \cdot I_{rms} = V \cdot A$$

Let us consider commercial inductor,

$$Z = R + jXL$$

Where, Z = impedance of the coil

R = internal resistance of the coil

XL = reactance offered by the coil.

$$I(t) Z = I(t) R + I(t) jXL$$

$$I^2 Z = I^2 R + j I^2 XL$$

$$P_a = P_{av} + j P_r$$

$$P_{av} = P_a \cos \Phi = V_{rms} \cdot I_{rms} \cos \Phi = \text{active power} = W$$

$$P_r = P_a \sin \Phi = V_{rms} \cdot I_{rms} \sin \Phi = \text{reactive power} = VAR$$

Let us consider commercial capacitor

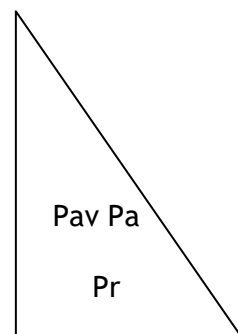

power triangle with phase Φ

$$Z = R - jXC$$

Where, Z = impedance of the capacitor

R = internal resistance of the capacitor

XC = reactance offered by the capacitor.

$$I(t) Z = I(t) R - I(t) jXC$$

$$I^2 Z = I^2 R - j I^2 XC$$

$$P_a = P_{av} - j P_r$$

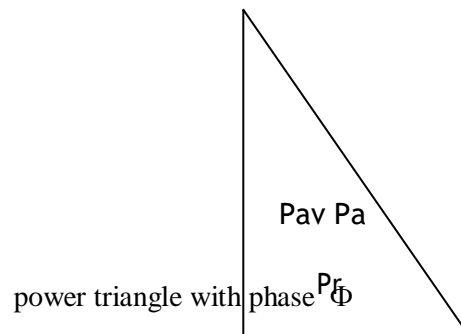

$$P_{av} = P_a \cos \Phi = V_{rms}.I_{rms} \cos \Phi = \text{active power} = W$$

$$P_r = P_a \sin \Phi = V_{rms}.I_{rms} \sin \Phi = \text{reactive power} = VAR$$

Complex power:

Complex power is represented with S.

$$S = V(t).i(t)^*$$

$$= P + jQ \text{ or } P - jQ$$

Where, P = active power

Q = reactive power

Here only useful power is true power where as net reactive power over an cycle will be zero.

Complex numbers:

Complex numbers can be represented in two ways, either rectangle form or polar form

Rectangular form = $a + j b$

Polar form = $\tan^{-1} (b/a)$

Here j operator plays major role in complex number, which is define unit vector rotating in anti-clock wise direction with phase 90.

$$j = 1 =$$

$$j^2 = -1$$

$$j^3 = -$$

RLC series A.C. circuits

The e.m.f. that is supplied to the circuit is distributed between the resistor, the inductor, and the capacitor. Since the elements are in series the common current is taken to have the reference phase.

$$I = I_m \exp[j\omega t]$$

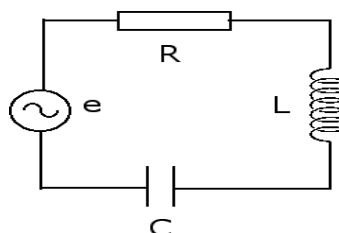

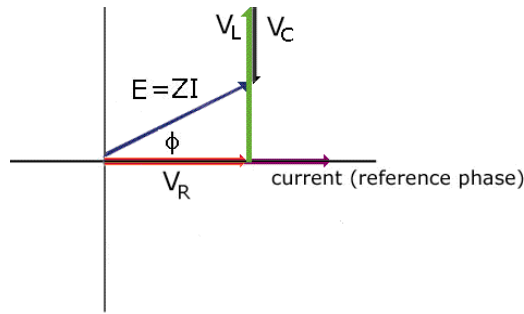

Adding the potentials around the circuit:

$$\begin{aligned}
 \underline{E} &= \underline{V}_R + \underline{V}_L + \underline{V}_C \\
 &= R\underline{I} + j\omega L\underline{I} - \frac{j}{\omega C}\underline{I} \\
 &= \left(R + j\left\{ \omega L - \frac{1}{\omega C} \right\} \right) I_m \exp[j\omega t] \\
 &= \sqrt{R^2 + \left\{ \omega L - \frac{1}{\omega C} \right\}^2} \exp\left[+j \tan^{-1} \left(\frac{\omega L - \frac{1}{\omega C}}{R} \right) \right] I_m \exp[j\omega t]
 \end{aligned}$$

$$\underline{E} = ZI_m \exp[j(\omega t + \phi)], \quad \text{where}$$

$$Z = \sqrt{R^2 + \left\{ \omega L - \frac{1}{\omega C} \right\}^2}, \quad \text{and} \quad \tan \phi = \frac{\omega L - \frac{1}{\omega C}}{R}$$

The physical current and potentials are:

$$\begin{aligned}
 i &= \text{Im}\{I_m \exp[j\omega t]\} &= I_m \sin \omega t \\
 v_R &= \text{Im}\{RI_m \exp[j\omega t]\} &= RI_m \sin \omega t \\
 v_L &= \text{Im}\{j\omega LI_m \exp[j\omega t]\} &= \omega LI_m \sin\left(\omega t + \frac{\pi}{2}\right) \\
 v_C &= \text{Im}\left\{\frac{I_m}{j\omega C} \exp[j\omega t]\right\} &= \frac{I_m}{\omega C} \sin\left(\omega t - \frac{\pi}{2}\right) \\
 e &= \text{Im}\{ZI_m \exp[j(\omega t + \phi)]\} &= ZI_m \sin(\omega t + \phi)
 \end{aligned}$$

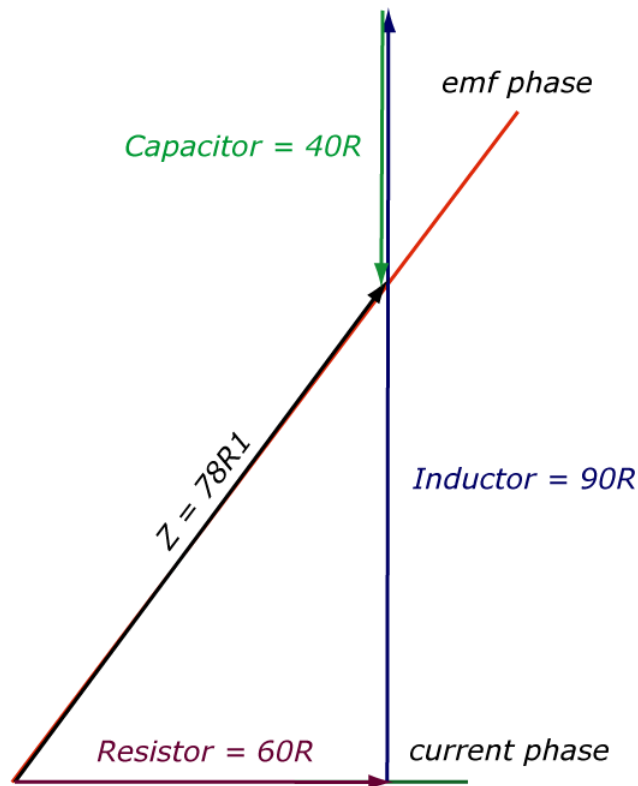

Example

A 240V, $250/\pi$ Hz supply is connected in series with 60R, 180mH and 50 μ F. Take the emf as the reference phase and find:

- the complex impedance of the circuit
- the complex, real (i.e. physical) and rms currents, and
- the complex, real (i.e. physical) and rms potential differences across each element.

$$\omega = 2\pi \left(\frac{250}{\pi} \right) = 500 \text{ rad.s}^{-1}$$

$$\begin{aligned} \underline{Z} &= R + j\omega L - \frac{j}{\omega C} \\ &= 60 + j500 \times (180 \times 10^{-3}) - \frac{j}{500 \times (50 \times 10^{-6})} \\ &= 60 + j(90 - 40) \\ &= \sqrt{60^2 + (90 - 40)^2} \exp \left[j \tan^{-1} \frac{50}{60} \right] \\ &= 78.1 \exp[0.69j] \quad (\phi = 39.8^\circ) \end{aligned}$$

The complex impedance for the circuit is 78.1Ω , and the phase angle between current and applied emf is 0.69 radians (or 39.8°).

$$\underline{E} = 240 \text{ V} \quad \therefore E_m = 240\sqrt{2} = 339 \text{ V}$$

$$\underline{E} = 339 \exp[j(500t)]$$

$$\underline{I} = \frac{\underline{E}}{\underline{Z}} = \frac{339}{78.1} \exp[j(500t - 0.69)]$$

$$\underline{I} = 4.3 \exp[j(500t - 0.69)] \text{ A}$$

$$i = 4.3 \sin(500t - 0.69) \text{ A}$$

$$I = \frac{E}{Z} = \frac{240}{78.1} \quad \text{or} \quad = \frac{4.3}{\sqrt{2}} = 3 \text{ A}$$

$$\underline{V}_R = R\underline{I} = 60 \times 4.3 \exp[j(500t - 0.69)] \text{ V}$$

$$\underline{V}_R = 255 \times \exp[j(500t - 0.69)] \text{ V}$$

$$v_R = 255 \times \sin(500t - 0.69) \text{ V}$$

$$V_R = \frac{255}{\sqrt{2}} \quad \text{or} \quad = 60 \times 3 = 180 \text{ V}$$

$$\begin{aligned} \underline{V}_L &= j\omega L \underline{I} = 90j \times 4.3 \exp[j(500t - 0.69)] \\ &= 90 \exp\left[\frac{\pi}{2}j\right] \times 4.3 \exp[j(500t - 0.69)] \\ &= 382 \exp\left[j\left(500t - 0.69 + \frac{\pi}{2}\right)\right] \end{aligned}$$

$$\underline{V}_L = 382 \exp[j(500t + 0.88)] \text{ V}$$

$$v_L = 382 \sin(500t + 0.88) \text{ V}$$

$$V_L = \frac{382}{\sqrt{2}} \quad \text{or} \quad = 90 \times 3 = 270 \text{ V}$$

$$\begin{aligned} \underline{V}_C &= -\frac{j}{\omega C} \underline{I} = 40 \exp\left[-\frac{\pi}{2}j\right] \times 4.3 \exp[j(500t - 0.69)] \\ &= 172 \exp\left[j\left(500t - \frac{\pi}{2} - 0.69\right)\right] \end{aligned}$$

$$\underline{V}_C = 172 \exp[j(500t - 2.27)] \quad (\phi = -129.8^\circ)$$

$$v_C = 172 \sin(500t - 2.27) \text{ V}$$

$$V_C = \frac{172}{\sqrt{2}} \quad \text{or} \quad = 40 \times 3 = 120 \text{ V}$$

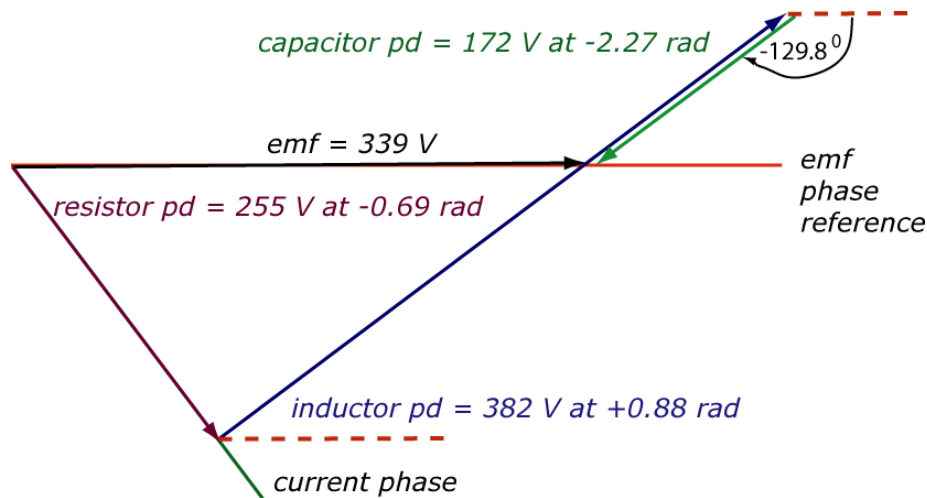

Complex potentials and currents hold both magnitude and phase information. Resistor/Capacitor and Resistor/Inductor circuits can form filters to block high or low frequency signals.

Average Power is calculated with rms quantities. Apparent Power is the product of applied emf and current. Real Power is the product of applied emf, current and $\cos(\text{the phase angle between emf and current})$ (in Watt). $\cos(\text{phase angle between emf and current})$ is called the power factor. Apparent and Complex power are given the unit VA (Volt Amp). Reactive Power is given the unit VAR (Volt Amp Reactive).

However, the analysis of a parallel RLC circuits can be a little more mathematically difficult than for series RLC circuits so in this tutorial about parallel RLC circuits only pure components are assumed in this tutorial to keep things simple.

This time instead of the current being common to the circuit components, the applied voltage is now common to all so we need to find the individual branch currents through each element. The total impedance, Z of a parallel RLC circuit is calculated using the current of the circuit similar to that for a DC parallel circuit, the difference this time is that admittance is used instead of impedance. Consider the parallel RLC circuit below.

Parallel RLC Circuit

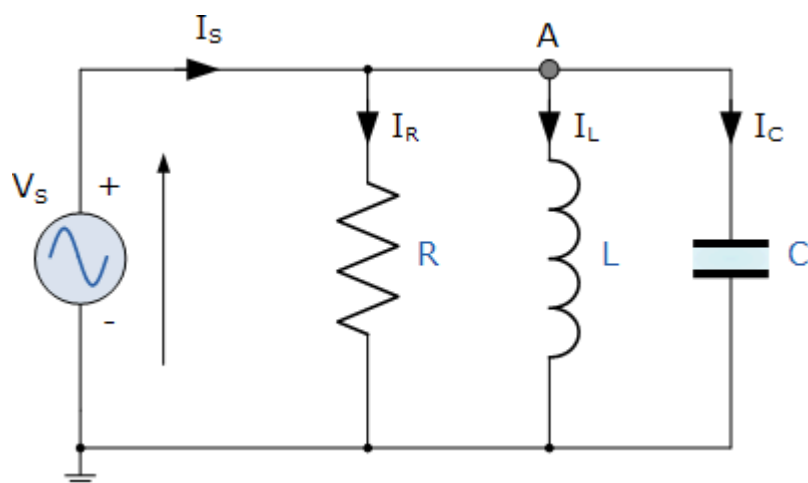

In the above parallel RLC circuit, we can see that the supply voltage, V_s is common to all three components whilst the supply current I_s consists of three parts. The current flowing through the resistor, I_R , the current flowing through the inductor, I_L and the current through the capacitor, I_C .

But the current flowing through each branch and therefore each component will be different to each other and to the supply current, I_s . The total current drawn from the supply will not be the mathematical sum of the three individual branch currents but their vector sum.

Like the series RLC circuit, we can solve this circuit using the phasor or vector method but this time the vector diagram will have the voltage as its reference with the three current vectors plotted with respect to the voltage. The phasor diagram for a parallel RLC circuit is produced by combining together the three individual phasors for each component and adding the currents vectorially.

Since the voltage across the circuit is common to all three circuit elements we can use this as the reference vector with the three current vectors drawn relative to this at their corresponding angles. The resulting vector I_S is obtained by adding together two of the vectors, I_L and I_C and then adding this sum to the remaining vector I_R . The resulting angle obtained between V and I_S will be the circuit's phase angle as shown below.

Phasor Diagram for a Parallel RLC Circuit

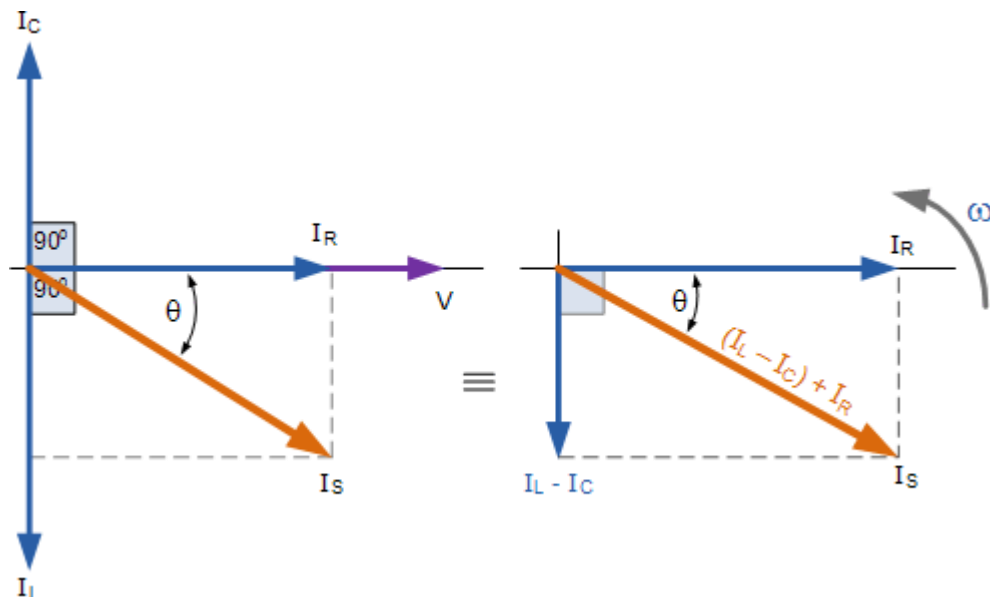

We can see from the phasor diagram on the right hand side above that the current vectors produce a rectangular triangle, comprising of hypotenuse I_S , horizontal axis I_R and vertical axis $I_L - I_C$. Hopefully you will notice then, that this forms a **Current Triangle** and we can therefore use Pythagoras's theorem on this current triangle to mathematically obtain the magnitude of the branch currents along the x-axis and y-axis and then determine the total current I_S of these components as shown.

Current Triangle for a Parallel RLC Circuit

$$I_S^2 = I_R^2 + (I_L - I_C)^2$$

$$I_S = \sqrt{I_R^2 + (I_L - I_C)^2}$$

$$\therefore I_S = \sqrt{\left(\frac{V}{R}\right)^2 + \left(\frac{V}{X_L} - \frac{V}{X_C}\right)^2} = \frac{V}{Z}$$

$$\text{where: } I_R = \frac{V}{R}, \quad I_L = \frac{V}{X_L}, \quad I_C = \frac{V}{X_C}$$

Since the voltage across the circuit is common to all three circuit elements, the current through each branch can be found using Kirchoff's Current Law, (KCL). Kirchoff's current law or junction law states that "the total current entering a junction or node is exactly equal to the current leaving that node", so the currents entering and leaving node "A" above are given as:

$$\text{KCL: } I_s - I_R - I_L - I_C = 0$$

$$I_s - \frac{V}{R} - \frac{1}{L} \int v dt - C \frac{dv}{dt} = 0$$

Taking the derivative, dividing through the above equation by C and rearranging gives us the following Second-order equation for the circuit current. It becomes a second-order equation because there are two reactive elements in the circuit, the inductor and the capacitor.

$$I_s - \frac{d^2V}{dt^2} - \frac{dV}{RCdt} - \frac{V}{LC} = 0$$

$$\therefore I_{s(t)} = \frac{d^2V}{dt^2} + \frac{dV}{dt} \frac{1}{RC} + \frac{1}{LC} V$$

The opposition to current flow in this type of AC circuit is made up of three components: X_L , X_C and R and the combination of these three gives the circuit impedance, Z . We know from above that the voltage has the same amplitude and phase in all the components of a parallel RLC circuit. Then the impedance across each component can also be described mathematically according to the current flowing through and the voltage across each element as.

Impedance of a Parallel RLC Circuit

$$R = \frac{V}{I_R} \quad X_L = \frac{V}{I_L} \quad X_C = \frac{V}{I_C}$$

$$Z = \frac{1}{\sqrt{\left(\frac{1}{R}\right)^2 + \left(\frac{1}{X_L} - \frac{1}{X_C}\right)^2}}$$

$$\therefore \frac{1}{Z} = \sqrt{\left(\frac{1}{R}\right)^2 + \left(\frac{1}{X_L} - \frac{1}{X_C}\right)^2}$$

You will notice that the final equation for a parallel RLC circuit produces complex impedance's for each parallel branch as each element becomes the reciprocal of impedance, ($1/Z$) with the reciprocal of impedance being called **Admittance**.

In parallel AC circuits it is more convenient to use **admittance**, symbol (Y) to solve complex branch impedance's especially when two or more parallel branch impedance's are involved (helps with the math's). The total admittance of the circuit can simply be found by the addition of the parallel admittances. Then the total impedance, Z_T of the circuit will therefore be $1/Y_T$ Siemens as shown.

3.11.1 Admittance of a Parallel RLC Circuit

$$\frac{1}{Z_T} = Y_T = Y_1 + Y_2 + Y_3 + Y_4 + \dots \text{etc}$$

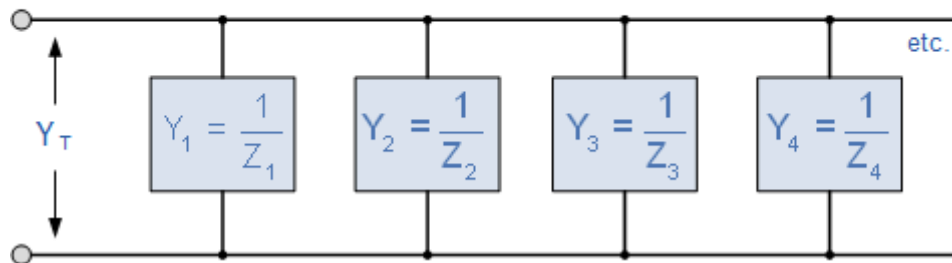

The new unit for admittance is the Siemens, abbreviated as S, (old unit mho's \mathcal{U} , ohm's in reverse). Admittances are added together in parallel branches, whereas impedance's are added together in series branches. But if we can have a reciprocal of impedance, we can also have a reciprocal of resistance and reactance as impedance consists of two components, R and X. Then the reciprocal of resistance is called **Conductance** and the reciprocal of reactance is called **Susceptance**.

Three Phase AC Circuits Introduction

Three-phase systems are commonly used in generation, transmission and distribution of electric power. Power in a three-phase system is constant rather than pulsating and three-phase motors start and run much better than single-phase motors. A three-phase system is a generator-load pair in which the generator produces three sinusoidal voltages of equal amplitude and frequency but differing in phase by 120° from each other.

There are two types of system available in electric circuit, single phase and **three phase system**. In single phase circuit, there will be only one phase, i.e the current will flow through only one wire and there will be one return path called neutral line to complete the circuit. So in single phase minimum amount of power can be transported. Here the generating station and load station will also be single phase. This is an old system using from previous time.

In polyphase system, that more than one phase can be used for generating, transmitting and for load system. **Three phase circuit** is the polyphase system where three phases are send together from the generator to the load. Each phase are having a phase difference of 120° , i.e 120° angle electrically. So from the total of 360° , three phases are equally divided into 120° each. The power in **three phase system** is continuous as all the three phases are involved in generating the total power. The sinusoidal waves for 3 phase system is shown below The three phases can be used as single phase each. So if the load is single phase, then one phase can be taken from the **three phase circuit** and the neutral can be used as ground to complete the circuit..

The phase voltages $v_a(t)$, $v_b(t)$ and $v_c(t)$ are as follows

$$\begin{aligned} v_a &= V_m \cos \omega t \\ v_b &= V_m \cos(\omega t - 120^\circ) \\ v_c &= V_m \cos(\omega t - 240^\circ), \end{aligned}$$

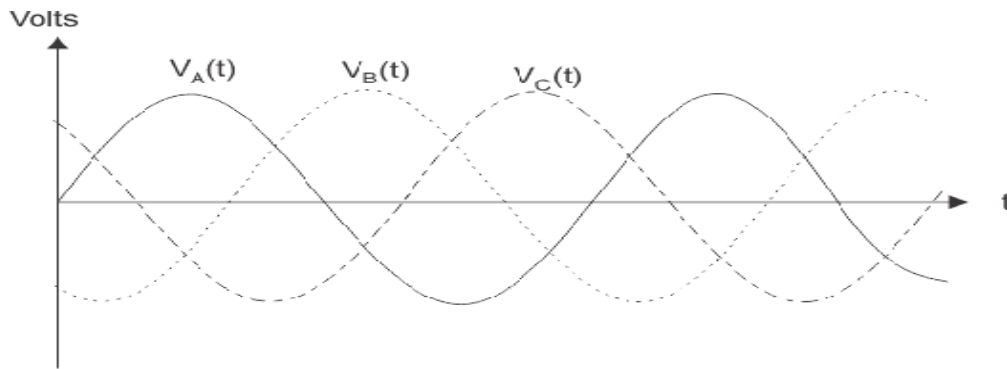

the corresponding phasors are

$$V_a = V_m$$

$$V_b = V_m e^{-j120^\circ}$$

$$V_c = V_m e^{-j240^\circ}$$

Basic Three-Phase Circuit

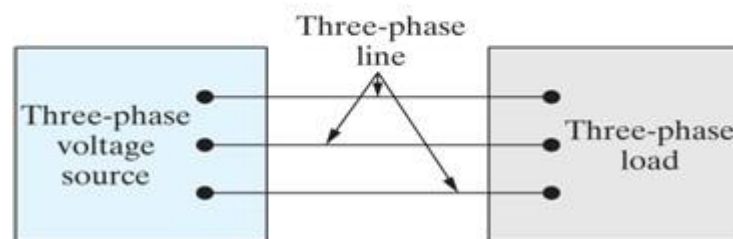

Basic three Phase Circuit

Advantages of Three Phase is preferred Over Single Phase

The three phase system can be used as three single phase line so it can act as three single phase system. The three phase generation and single phase generation is same in the generator except the arrangement of coil in the generator to get 120° phase difference. The conductor needed in three phase circuit is 75% that of conductor needed in single phase circuit. And also the instantaneous power in single phase system falls down to zero as in single phase we can see from the sinusoidal curve but in three phase system the net power from all the phases gives a continuous power to the load. they will have better and higher efficiency compared to the single phase system.

In three phase circuit, connections can be given in two types:

1. Star connection
2. Delta connection

STAR CONNECTION

In star connection, there is four wire, three wires are phase wire and fourth is neutral which is taken from the star point. Star connection is preferred for long distance power transmission because it is having the neutral point. In this we need to come to the concept of balanced and unbalanced current in power system.

When equal current will flow through all the three phases, then it is called as balanced current. And when the current will not be equal in any of the phase, then it is unbalanced current. In this case, during balanced condition there will be no current flowing through the neutral line and hence there is no use of the neutral terminal. But when there will be unbalanced current flowing in the three phase

circuit, neutral is having a vital role. It will take the unbalanced current through to the ground and protect the transformer. Unbalanced current affects transformer and it may also cause damage to the transformer and for this star connection is preferred for long distance transmission.

The Star Connection

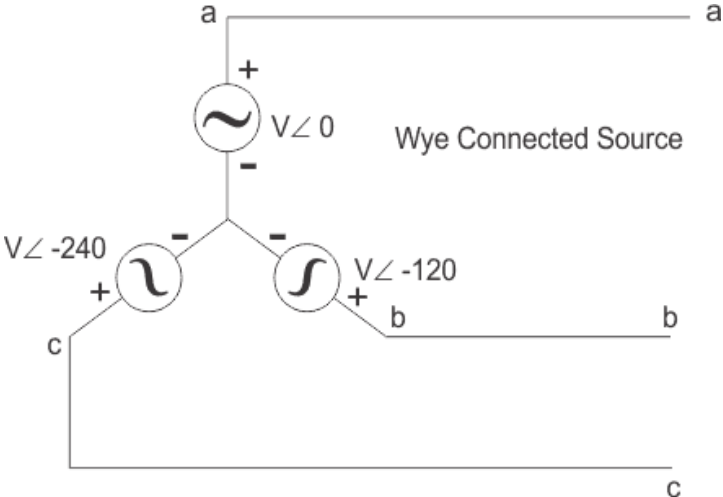

In star connection, the line voltage is $\sqrt{3}$ times of phase voltage. Line voltage is the voltage between two phases in three phase circuit and phase voltage is the voltage between one phase to the neutral line. And the current is same for both line and phase. It is shown as expression below

$$E_{Line} = \sqrt{3}E_{phase} \text{ and } I_{Line} = I_{Phase}$$

Delta Connection

In delta connection, there are three wires alone and no neutral terminal is taken. Normally delta connection is preferred for short distance due to the problem of unbalanced current in the circuit. The figure is shown below for delta connection. In the load station, ground can be used as neutral path if required. In delta connection, the line voltage is same with that of phase voltage. And the line current is $\sqrt{3}$ times of phase current. It is shown as expression below,

$$E_{Line} = E_{phase} \text{ and } I_{Line} = \sqrt{3}I_{Phase}$$

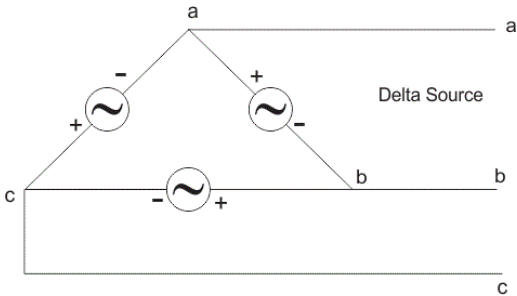

If we compare the line-to-neutral voltages with the line-to-line voltages, we find the following relationships,

Line-to-neutral voltages	Line-to-line voltages
$V_{an} = V_{rms} \angle 0^\circ$	$V_{ab} = \sqrt{3}V_{rms} \angle 30^\circ$
$V_{bn} = V_{rms} \angle -120^\circ$	$V_{bc} = \sqrt{3}V_{rms} \angle -90^\circ$
$V_{cn} = V_{rms} \angle 120^\circ$	$V_{ca} = \sqrt{3}V_{rms} \angle 150^\circ$

In three phase circuit, star and delta connection can be arranged in four different ways-

1. Star-Star connection
2. Star-Delta connection
3. Delta-Star connection
4. Delta-Delta connection

Phase Sequence

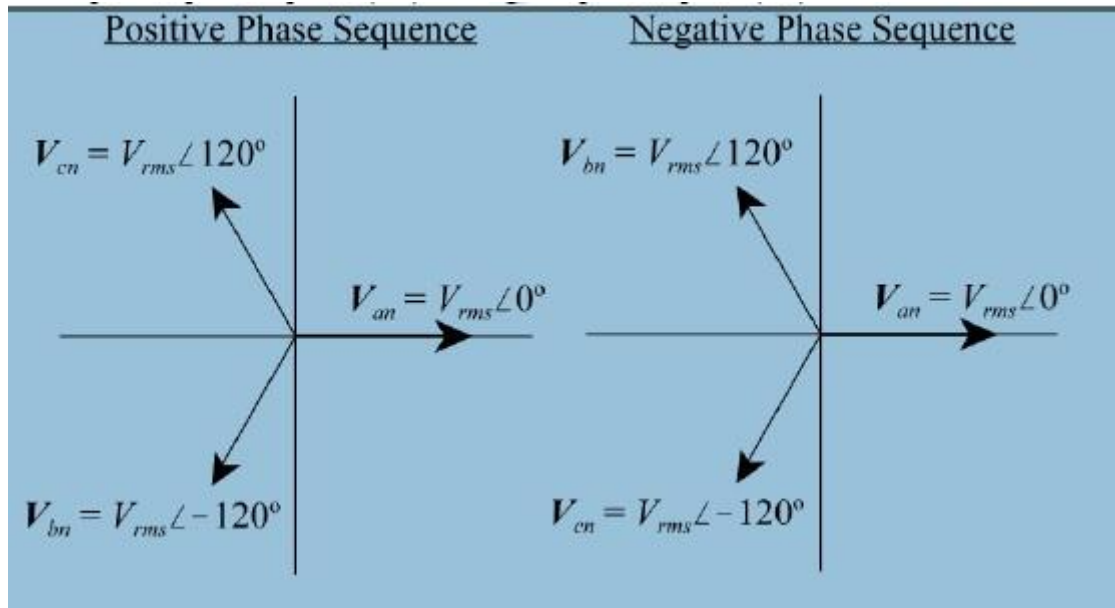

But the power is independent of the circuit arrangement of the three phase system. The net power in the circuit will be same in both star and delta connection. The power in three phase circuit can be calculated from the equation below,

$$P_{Total} = 3 \times E_{phase} \times I_{phase} \times PF$$

Since there is three phases, so the multiple of 3 is made in the normal power equation and the PF is power factor. Power factor is a very important factor in three phase system and sometimes due to certain error, it is corrected by using capacitors.

ANALYSIS OF BALANCED THREE PHASE CIRCUITS

In a balanced system, each of the three instantaneous voltages has equal amplitudes, but is separated from the other voltages by a phase angle of 120. The three voltages (or phases) are typically labeled a, b and c. The common reference point for the three phase voltages is designated as the neutral connection and is labeled as n.

A three-phase system is shown in Fig. In a special case all impedances are identical

$$Z_a = Z_b = Z_c = Z$$

Such a load is called a balanced load and is described by equations

$$I_a = \frac{V_a}{Z} \quad I_b = \frac{V_b}{Z} \quad I_c = \frac{V_c}{Z}$$

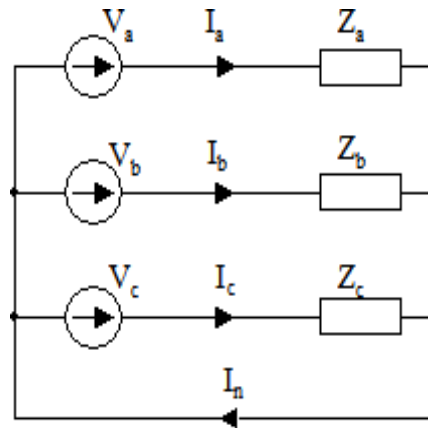

Using KCL, we have,

$$V_a + V_b + V_c = V_m \left(1 + e^{-j120^\circ} + e^{-j240^\circ} \right) = 0$$

$$I_n = I_a + I_b + I_c = \frac{1}{Z} (V_a + V_b + V_c), (4)$$

From the above result, we obtain $I_n = 0$.

Since the current flowing through the fourth wire is zero, the wire can be removed

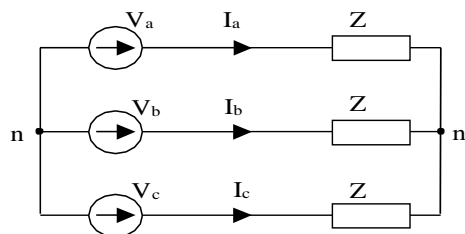

ANALYSIS OF UNBALANCED LOADS

Three-phase systems deliver power in enormous amounts to single-phase loads such as lamps, heaters, air-conditioners, and small motors. It is the responsibility of the power systems engineer to distribute these loads equally among the three-phases to maintain the demand for power fairly balanced at all times. While good balance can be achieved on large power systems, individual loads on smaller systems are generally unbalanced and must be analyzed as unbalanced three phase systems.

When the three phases of the load are not identical, an unbalanced system is produced. An unbalanced Y-connected system is shown in Fig.1. The system of Fig.1 contains perfectly conducting wires connecting the source to the load. Now we consider a more realistic case where the wires are represented by impedances Z_p and the neutral wire connecting n and n' is represented by impedance Z_n

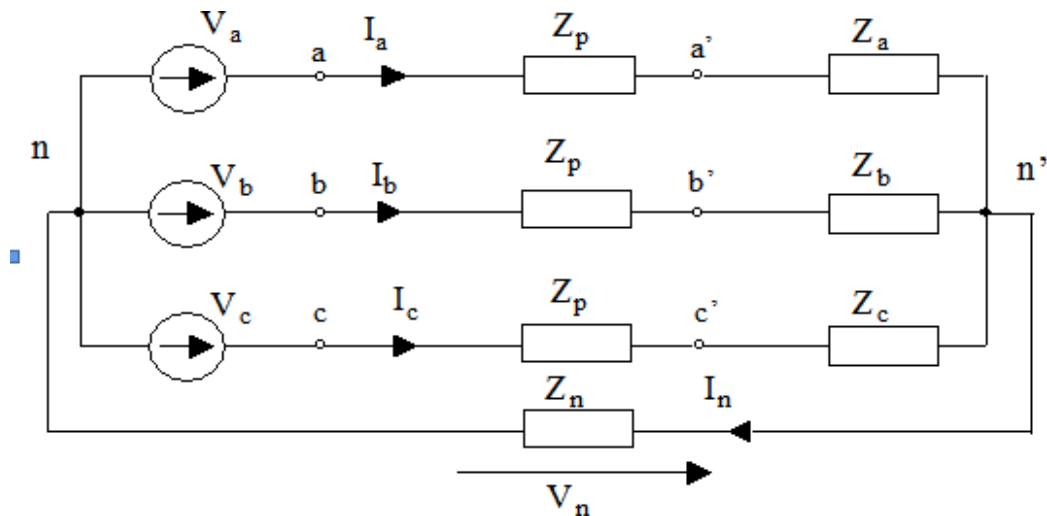

the node n as the datum, we express the currents I_a , I_b , I_c and I_n in terms of the node voltage V_n

$$I_a = \frac{V_a - V_n}{Z_a + Z_p}$$

$$I_b = \frac{V_b - V_n}{Z_b + Z_p}$$

$$I_c = \frac{V_c - V_n}{Z_c + Z_p}$$

$$I_n = \frac{V_n}{Z_n}$$

The node equation is

$$\frac{V_n}{Z_n} - \frac{V_a - V_n}{Z_a + Z_p} - \frac{V_b - V_n}{Z_b + Z_p} - \frac{V_c - V_n}{Z_c + Z_p} = 0$$

$$\text{And } V_n = \frac{\frac{V_a}{Z_a + Z_p} + \frac{V_b}{Z_b + Z_p} + \frac{V_c}{Z_c + Z_p}}{\frac{1}{Z_n} + \frac{1}{Z_a + Z_p} + \frac{1}{Z_b + Z_p} + \frac{1}{Z_c + Z_p}}$$

Power in three-phase circuits

In the balanced systems, the average power consumed by each load branch is the same and given by

$$\tilde{P}_{av} = V_{eff} I_{eff} \cos \phi$$

where V_{eff} is the effective value of the phase voltage, I_{eff} is the effective value of the phase current and ϕ is the angle of the impedance. The total average power consumed by the load is the sum of those consumed by each branch, hence, we have

$$P_{av} = 3\tilde{P}_{av} = 3V_{eff} I_{eff} \cos \phi$$

In the balanced Y systems, the phase current has the same amplitude as the line current

$I_{\text{eff}} = (I_{\text{eff}})_L$, whereas the line voltage has the effective value $(V_{\text{eff}})_L$ which is $\sqrt{3}$ times greater than the effective value of the phase voltage, $(V_{\text{eff}})_L = \sqrt{3}V_{\text{eff}}$. Hence, using (22), we obtain

Measurement of Three Phase Power by Two Wattmeters Method

In this method we have two types of connections

(a) Star connection of loads

(b) Delta connection of loads.

When the star connected load, the diagram is shown in below-

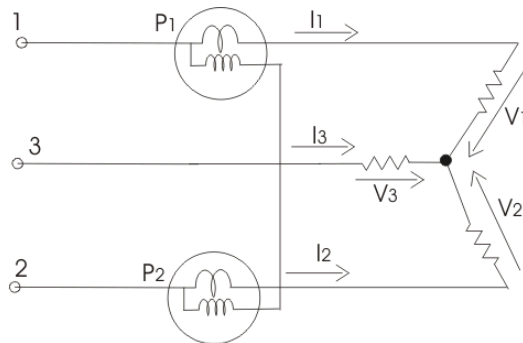

$$P = P_1 + P_2 = I_1(V_1 + V_2) + I_2(V_2 - V_3)$$

But we have $I_1 + I_2 + I_3 = 0$, hence putting the value of $I_1 + I_2 = -I_3$. We get total power as $V_1 I_1 + V_2 I_2 + V_3 I_3$.

For delta connected load, the diagram is shown in below

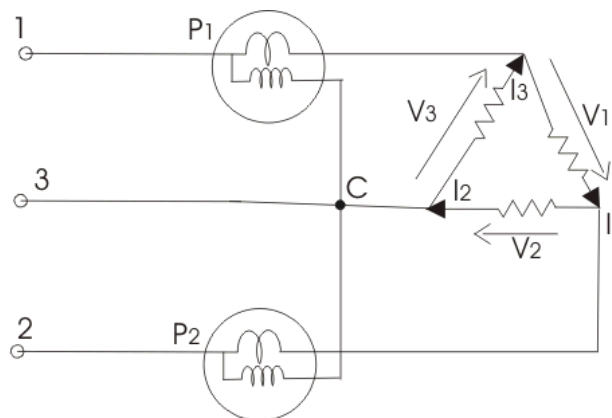

The reading of wattmeter one can be written as

$$P_1 = -V_3(I_1 - I_3)$$

And reading of wattmeter two is

$$P_2 = -V_2(I_2 - I_1)$$

$$\text{Total power is } P = P_1 + P_2 = V_2 I_2 + V_3 I_3 - I_1(V_2 + V_3)$$

But $V_1 + V_2 + V_3 = 0$, hence expression for total power will reduce to $V_1 I_1 + V_2 I_2 + V_3 I_3$

13.16 Measurement of Three Phase Power by One Wattmeter Method

Limitation of this method is that it cannot be applied on unbalanced load. So under this condition we have $I_1=I_2=I_3=I$ and $V_1=V_2=V_3=V$.

Diagram is shown below:

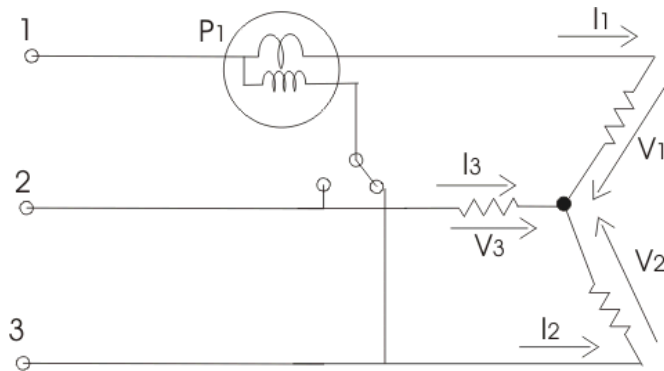

Two switches are given which are marked as 1-3 and 1-2, by closing the switch 1-3 we get reading of wattmeter as

$$P_1 = V_{13} I_1 \cos(30 - \phi) = \sqrt{3} \times V I \cos(30 - \phi)$$

Similarly the reading of wattmeter when switch 1-2 is closed is

$$P_2 = V_{12} I_1 \cos(30 + \phi) = \sqrt{3} \times V I \cos(30 + \phi)$$

$$\text{Total power is } P_1 + P_2 = 3VI \cos \phi$$

UNIT IV SEMICONDUCTOR DIODE AND APPLICATIONS

INTRODUCTION:

We start our study of nonlinear circuit elements. These elements (diodes and transistors) are made of semiconductors. A brief description of how semiconductor devices work is first given to understand their $i-v$ characteristics. You will see a rigorous analysis of semiconductors in the breadth courses.

Energy Bands in Solids:

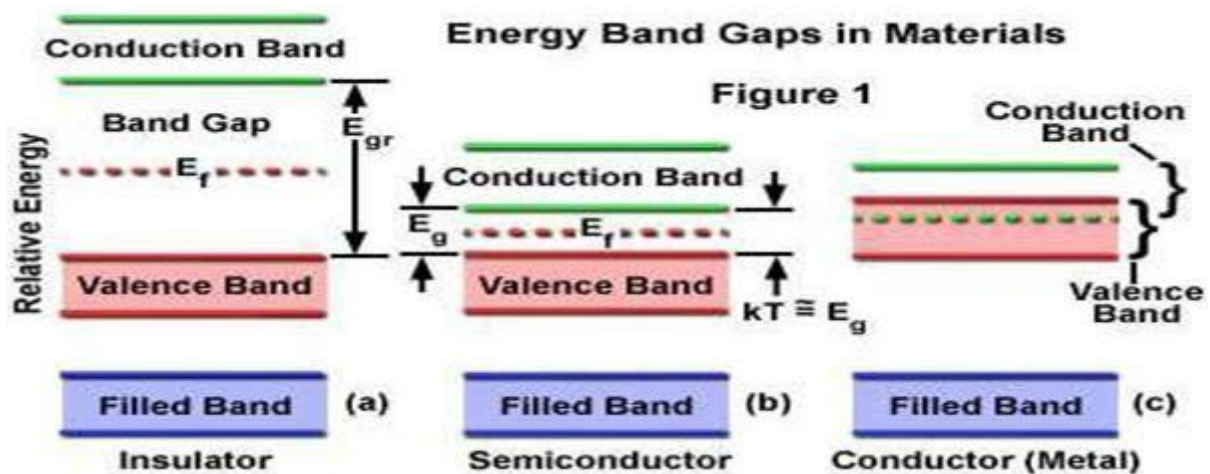

Semiconductors:

Semiconductor materials are mainly made of elements from group IVB of the periodic table like C (diamond), Si, Ge, SiC. These materials have 4 electrons in their outermost electronic shell. Each atom can form a "covalent" bond with four of its neighbors sharing one electron with that atom. In this manner, each atom "sees" eight electrons in its outermost electronic shell (4 of its own, and one from each neighbor), completely filling that shell. It is also possible to form this type of covalent bond by combining elements from group IIIA (sharing three electrons) with an element from group VA (sharing five electrons). Examples of these semiconductors are GaAs or AlGaAs and are usually called "3-5" semiconductors. We focus mostly on Si semiconductors in this class. Figure below shows this covalent

bond structure for Si. A pair of electrons and holes are shown. Note that Si forms a tetrahedron structure and an atom in the center of the tetrahedron shares electrons with atoms on the each vertex. Figure below is a two-dimensional representation of such a structure. The left figure is for a pure Si semiconductor and an electron-hole pair is depicted. Both electrons and holes are called "mobile" carriers as they are responsible for carrying electric current.

If we add a small amount of an element from group VA, such as P, to the semiconductor, we create an n-type semiconductor and the impurity dopant is called an n-type dopant. Each of these new atoms also forms a covalent bond with four of its neighbors. However, as an n-type dopant has 5 valence electrons, the extra electron will be located in the "empty" energy band. As can be seen, there is no hole associated with this electron. In addition to electrons from the n-type dopant, there are electron-hole pairs in the solid from the base semiconductor (Si in the above figure) which are generated due to temperature effects. In an n-type semiconductor, the number of free electrons from the dopant is much larger than the number of electrons from electron-hole pairs. As such, an n-type semiconductor is considerably more conductive than the base semiconductor (in this respect, an n-type semiconductor is more like a "resistive" metal than a semiconductor).

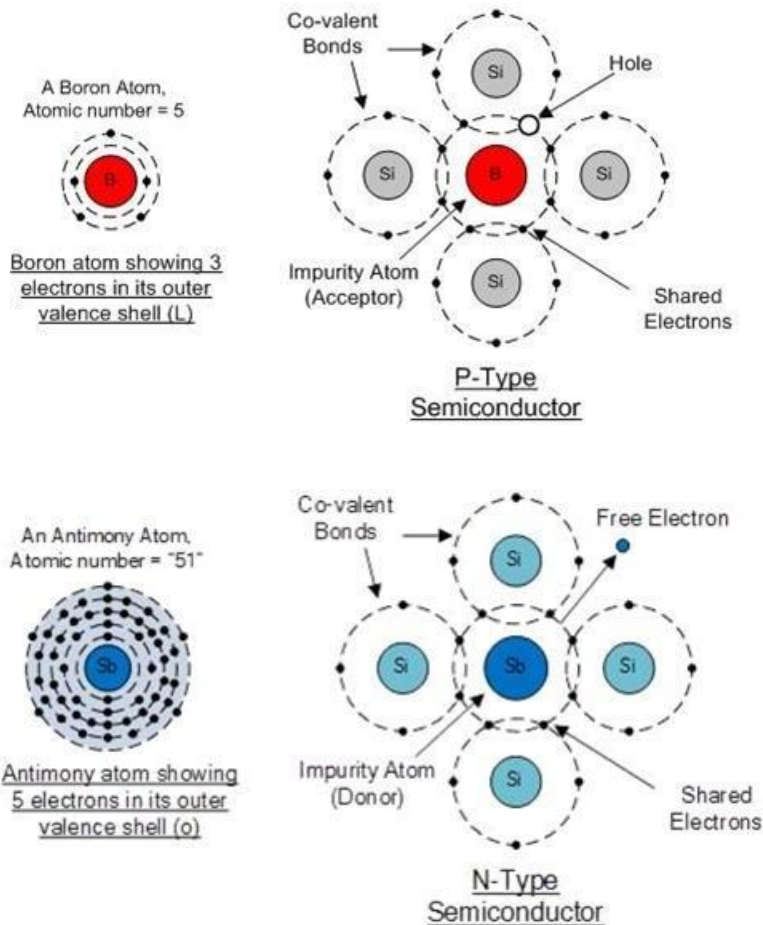

In summary, in a n-type semiconductor there are two charge carriers: "holes" from the base semiconductor (called the "minority" carriers) and electrons from both the n-type dopant and electron-hole pairs (called the "majority" carrier).

Similarly, we can create a p-type semiconductor by adding an element from group IIIA, such as B, to the semiconductor. In this case, the p-type dopant generate holes. We will have two charge carriers: majority carriers are "holes" from the p-type dopant and electron-hole pairs and minority carriers are electrons from the base semiconductor (from electron-hole pairs).

The charge carriers (electrons and holes) move in a semiconductor through two mechanisms: First, charge carriers would move from regions of higher concentration to lower concentration in order to achieve a uniform distribution throughout the semiconductor. This process is called **Diffusion** and is characterized by the diffusion coefficient, D . Second, charge carriers move under the influence of an electric field. This motion is called the drift and is characterized by the mobility.

4.2 DIODE | WORKING PRINCIPLE AND TYPES OF DIODE

What is a Diode?

A diode is a device which only allows unidirectional flow of current if operated within a rated specified voltage level. A diode only blocks current in the reverse direction while the reverse voltage is within a limited range otherwise reverse barrier breaks and the voltage at which this breakdown occurs is called reverse breakdown voltage. The diode acts as a valve in the electronic and electrical circuit. A P-N junction is the simplest form of the diode which behaves as ideally short circuit when it is in forward biased and behaves as ideally open circuit when it is in the reverse biased. Beside simple PN junction diodes, there are different types of diodes although the fundamental principle is more or less same. So a particular arrangement of diodes can convert AC to pulsating DC, and hence, it is

sometimes also called as a rectifier. The name diode is derived from "di-ode" which means a device having two electrodes.

4.2.1 Symbol of Diode

The symbol of a diode is shown below, the arrowhead points in the direction of conventional current flow.

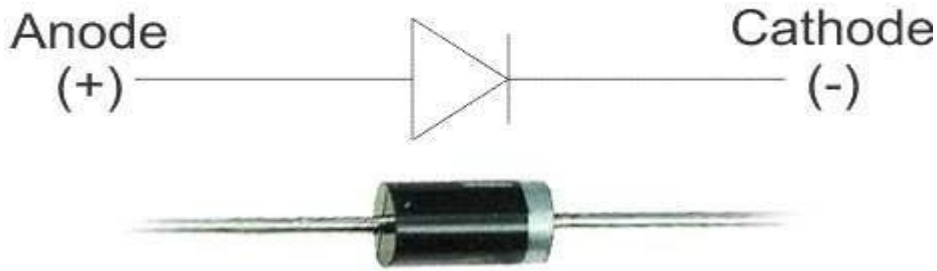

A simple **PN junction diode** can be created by doping donor impurity in one portion and acceptor impurity in other portion of a silicon or germanium crystal block. These make a p n junction at the middle portion of the block beside which one portion is p type (which is doped by trivalent or acceptor impurity) and other portion is n type (which is doped by pentavalent or donor impurity). It can also be formed by joining a p-type (intrinsic semiconductor doped with a trivalent impurity) and n-type semiconductor (intrinsic semiconductor doped with a pentavalent impurity) together with a special fabrication technique such that a p-n junction is formed. Hence, it is a device with two elements, the p-type forms anode and the n-type forms the cathode. These terminals are brought out to make the external connections.

4.2.3 Working Principle of Diode

The n side will have a large number of electrons and very few holes (due to thermal excitation) whereas the p side will have a high concentration of holes and very few electrons. Due to this, a process called diffusion takes place. In this process free electrons from the n side will diffuse (spread) into the p side and combine with holes present there, leaving a positive immobile (not moveable) ion in the n side. Hence, few atoms on the p side are converted into negative ions. Similarly, few atoms on the n-side will get converted to positive ions. Due to this large number of positive ions and negative ions will accumulate on the n-side and p-side respectively. This region so formed is called as depletion region. Due to the presence of these positive and negative ions a static electric field called as "barrier potential" is created across the p-n junction of the diode. It is called as "barrier potential" because it acts as a barrier and opposes the further migration of holes and electrons across the junction.

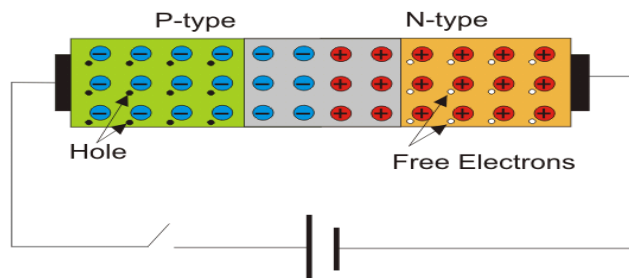

In a PN junction diode when the forward voltage is applied i.e. positive terminal of a source is connected to the p-type side, and the negative terminal of the source is connected to the n-type side, the diode is said to be in forward biased condition. We know that there is a barrier potential across the junction. This barrier potential is directed in the opposite of the forward applied voltage. So a diode can only allow current to flow in the forward direction when forward applied voltage is more than barrier potential of the junction. This voltage is called forward biased voltage. For silicon diode, it is 0.7 volts. For germanium diode, it is 0.3 volts. When forward applied voltage is more than this forward biased voltage, there will be forward current in the diode, and the diode will become short

circuited. Hence, there will be no more voltage drop across the diode beyond this forward biased voltage, and forward current is only limited by the external resistance" >resistance connected in series with the diode. Thus, if forward applied voltage increases from zero, the diode will start conducting only after this voltage reaches just above the barrier potential or forward biased voltage of the junction. The time taken by this input voltage to reach that value or in other words the time taken by this input voltage to overcome the forward biased voltage is called recovery time.

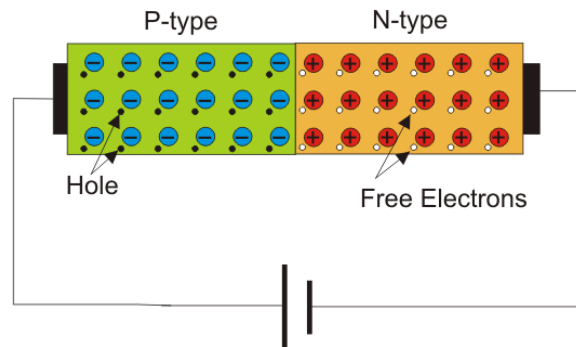

Now if the diode is reverse biased i.e. positive terminal of the source is connected to the n-type end, and the negative terminal of the source is connected to the p-type end of the diode, there will be no current through the diode except reverse saturation current. This is because at the reverse biased condition the depletion layer of the junction becomes wider with increasing reverse biased voltage. Although there is a tiny current flowing from n-type end to p-type end in the diode due to minority carriers. This tiny current is called reverse saturation current. Minority carriers are mainly thermally generated electrons and holes in p-type semiconductor and n-type semiconductor respectively. Now if reverse applied voltage across the diode is continually increased, then after certain applied voltage the depletion layer will destroy which will cause a huge reverse current to flow through the diode. If this current is not externally limited and it reaches beyond the safe value, the **diode** may be permanently destroyed. This is because, as the magnitude of the reverse voltage increases, the kinetic energy of the minority charge carriers also increase. These fast moving electrons collide with the other atoms in the device to knock-off some more electrons from them. The electrons so released further release much more electrons from the atoms by breaking the covalent bonds. This process is termed as carrier multiplication and leads to a considerable increase in the flow of current through the p-n junction. The associated phenomenon is called Avalanche Breakdown.

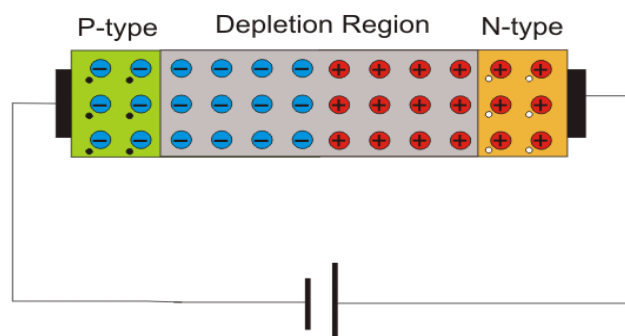

Types of Diode

Types of diodes:

- 1) Zener diode
- 2) P-N junction diode

- 3) Tunnel diode
- 4) Varractor diode
- 5) Schottky diode
- 6) Photo diode
- 7) PIN diode
- 8) Laser diode
- 9) Avalanche diode
- 10) Light emitting diode

DIODE CHARACTERISTICS

Semiconductor materials (Si, Ge) are used to form variety of electronic devices. The most basic device is diode. Diode is a two terminal P-N junction device. P-N junction is formed by bringing a P type material in contact with N type material. When a P-type material is brought in contact with N- type material electrons and holes start recombining near the junction. This result in lack of charge carriers at the junction and thus the junction is called depletion region. Symbol of P-N junction is given as:

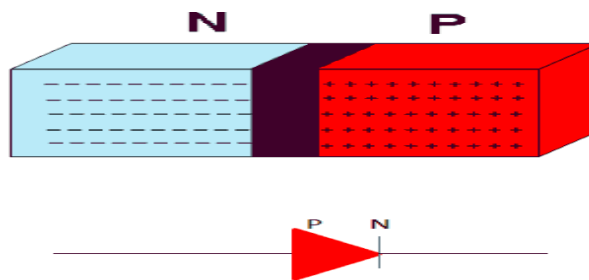

Biased i.e. when voltage is applied across the terminals of P-N junction, it is called diode.

Diode is unidirectional device that allows the flow of current in one direction only depending on the biasing.

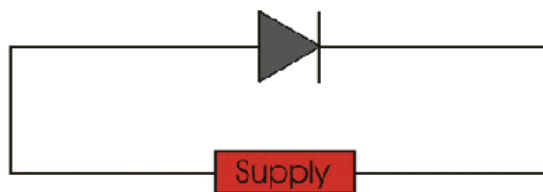

Forward Biasing Characteristic of Diode

When, P terminal is more positive as compared to N terminal i.e. P- terminal connected to positive terminal of battery and N-terminal connected to negative terminal of battery, it is said to be forward biased.

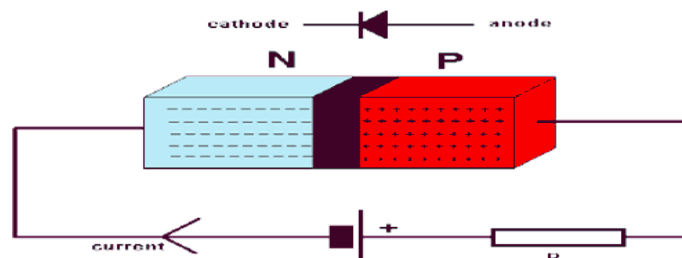

Positive terminal of the battery repels majority carriers, holes, in P-region and negative terminal repels electrons in the N-region and push them towards the junction. This result in increase in concentration of charge carriers near junction, recombination takes place and width of depletion region decreases. As forward bias voltage is raised depletion region continues to reduce in width, and more and more carriers recombine. This results in exponential rise of current.

Reverse Biasing Characteristic of Diode

In reverse biasing P- terminal is connected to negative terminal of the battery and N- terminal to positive terminal of battery. Thus applied voltage makes N-side more positive than P-side.

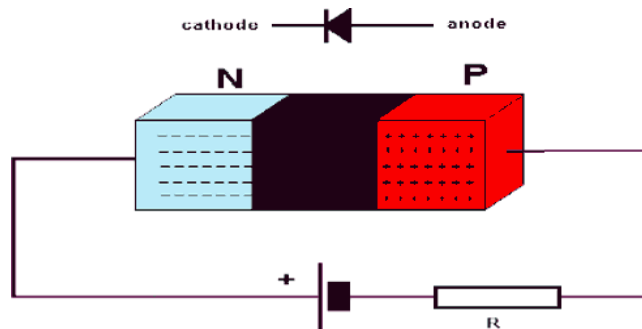

Negative terminal of the battery attracts majority carriers, holes, in P-region and positive terminal attracts electrons in the N-region and pull them away from the junction. This result in decrease in concentration of charge carriers near junction and width of depletion region increases. A small amount of current flow due to minority carriers, called as reverse bias current or leakage current. As reverse bias voltage is raised depletion region continues to increase in width and no current flows. It can be concluded that diode acts only when forward biased. Operation of diode can be summarized in form of I-V **diode characteristics** graph. For reverse bias diode, $V < 0$, $I_D = I_S$ Where, V = supply voltage I_D = diode current I_S = reverse saturation current For forward bias, $V > 0$, $I_D = I_S(e^{V/NV_T} - 1)$

Where,

$$V_T = \text{volt's equivalent of temperature} = \frac{KT}{Q} = \frac{T}{11600}$$

$$Q = \text{electronic charge} = 1.632 \times 10^{-19} \text{ C}$$

$$K = \text{Boltzmann's constant} = 1.38 \times 10^{-23}$$

$$N = 1, \text{ for Ge}$$

$$= 2, \text{ for Si}$$

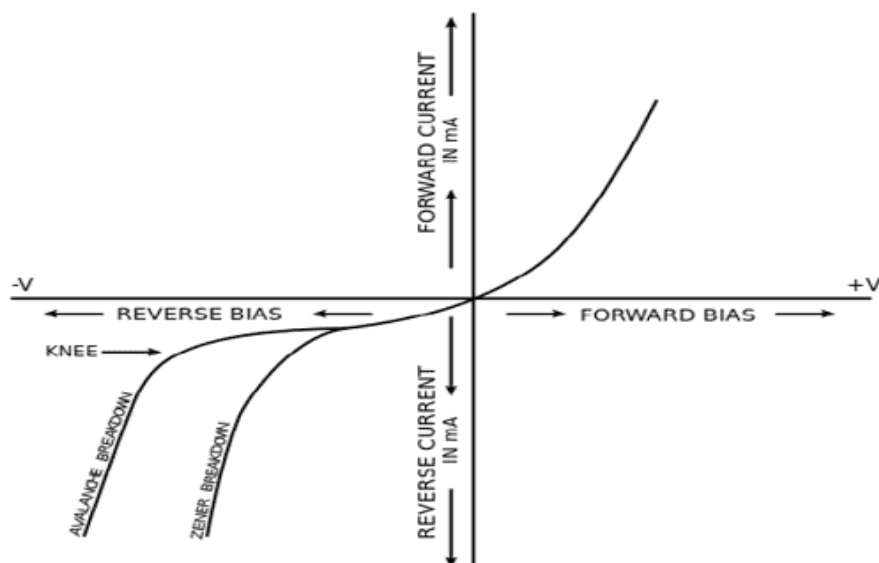

As reverse bias voltage is further raised, depletion region width increases and a point comes when junction breaks down. This results in large flow of current. Breakdown is the knee of **diode characteristics** curve. Junction breakdown takes place due to two phenomena

Avalanche Breakdown(for $V > 5V$)

Under very high reverse bias voltage kinetic energy of minority carriers become so large that they knock out electrons from covalent bonds, which in turn knock more electrons and this cycle continues until and unless junction breakdowns.

Zener Effect (for $V < 5V$)

Under reverse bias voltage junction barrier tends to increase with increase in bias voltage. This results in very high static electric field at the junction. This static electric field breaks covalent bond and set minority carriers free which contributes to reverse current. Current increases abruptly and junction breaks down.

P-N JUNCTION DIODE AND CHARACTERISTICS OF P-N JUNCTION

The volt-ampere characteristics of a diode explained by the following equations:

$$I = I_S(e^{V_D/(\eta V_T)} - 1)$$

Where

I = current flowing in the diode, I_0 = reverse saturation current

V_D = Voltage applied to the diode

V_T = volt- equivalent of temperature = $k T/q = T/ 11,600 = 26mV$ (@ room temp)

$\eta = 1$ (for Ge) and 2 (for Si)

It is observed that **Ge** diodes has smaller cut-in-voltage when compared to **Si** diode. The reverse saturation current in **Ge** diode is larger in magnitude when compared to silicon diode.

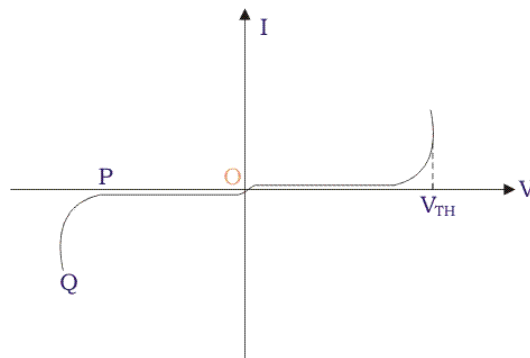

When, V is positive the junction is forward biased and when V is negative, the junction is reversing biased. When V is negative and less than V_{TH} , the current is very small. But when V exceeds V_{TH} , the current suddenly becomes very high. The voltage V_{TH} is known as threshold or cut in voltage. For Silicon diode $V_{TH} = 0.6 V$. At a reverse voltage corresponding to the point P, there is abrupt increment in reverse current. The PQ portion of the characteristics is known as breakdown region.

P-N Junction Band Diagram

For an n-type semiconductor, the Fermi level E_F lies near the conduction band edge. E_C but for an p-type semiconductor, E_F lies near the valance band edge E_V .

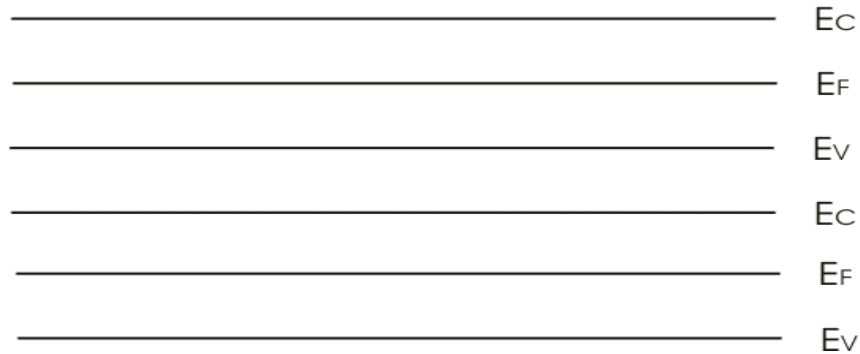

Now, when a p-n junction is built, the Fermi energy E_F attains a constant value. In this scenario the p-sides conduction band edge. Similarly n-side valance band edge will be at higher level than E_{cn} , n-sides conduction band edge of p-side. This energy difference is known as barrier energy. The barrier energy is $E_B = E_{cp} - E_{cn} = E_{vp} - E_{vn}$

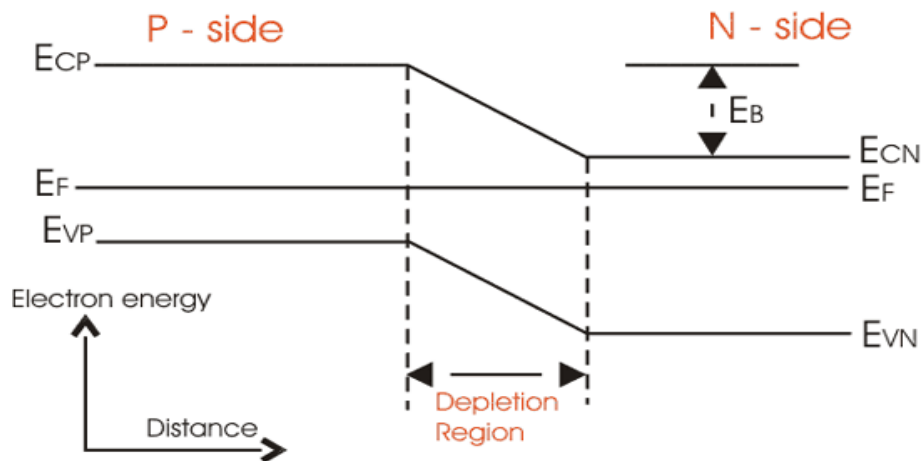

If we apply forward bias voltage V , across junction then the barrier energy decreases by an amount of eV and if V is reverse bias is applied the barrier energy increases by eV .

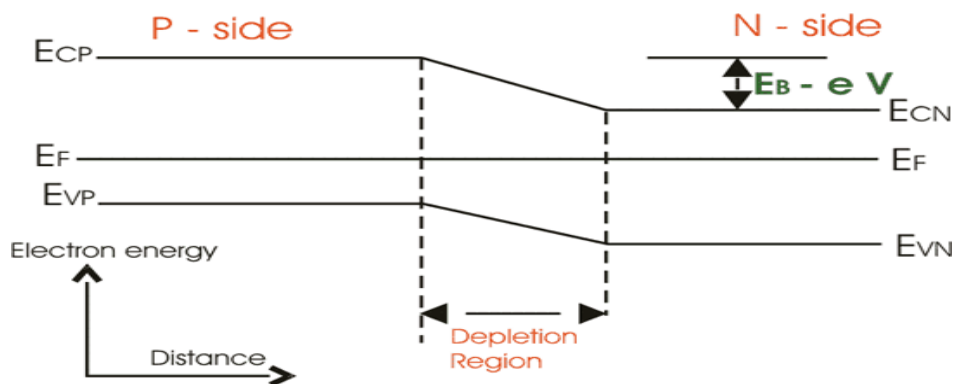

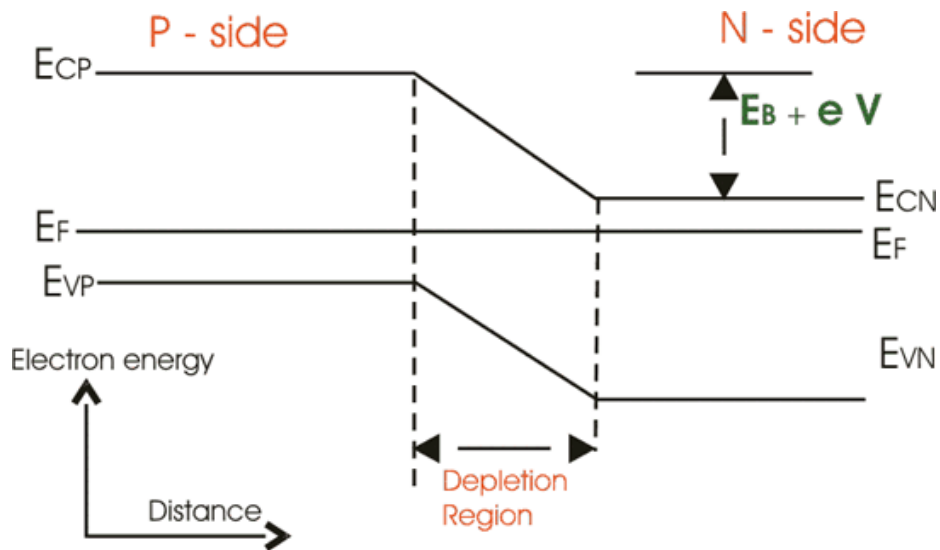

P-N Junction Diode Equation

The p-n junction diode equation for an ideal diode is given below

$$I = I_s[\exp(eV/K_B T) - 1]$$

Here,

I_s = reverse saturation current

e = charge of electron

K_B = Boltzmann constant

T = temperature For a normal p-n junction diode, the equation becomes

$$I = I_s[\exp(eV/\eta K_B T) - 1]$$

Here,

η = emission co-efficient, which is a number between 1 and 2, which typically increases as the current increases.

APPLICATIONS OF DIODES

- Rectifying a voltage, such as turning AC into DC voltages
- Isolating signals from a supply
- Voltage Reference
- Controlling the size of a signal
- Mixing signals
- Detection signals
- Lighting
- Lasers diodes

HALF WAVE DIODE RECTIFIER

Electric current flows through a p - n junction diode when it is forward biased and we get output current through the load. Let, we supply a sinusoidal voltage $V_{in} = V \sin \omega t$ as a source voltage. Now, if the input voltage is positive, the diode is forward biased and when that is negative, the diode is in reverse bias condition. When the input voltage is positive, i.e, for the positive cycle of the input voltage, the current flows through the diode.

So, the current will flow through the load also and we obtain output voltage across the load. But for the negative half cycle of the input, the p-n junction get reverse biased and no current flows through the diode as a result we obtain zero current and zero voltage across the load.

Circuit Diagram of Half Wave Rectifier

The basic diagram of **half wave diode rectifier** is given below,

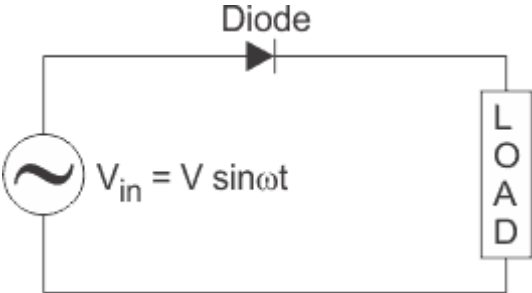

For positive half cycle



For negative half cycle

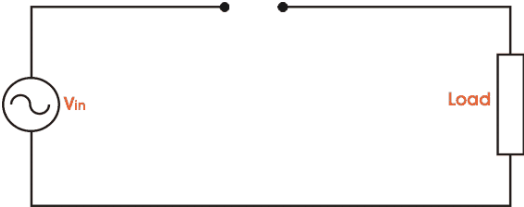

Input voltage and Output Voltage Waveforms

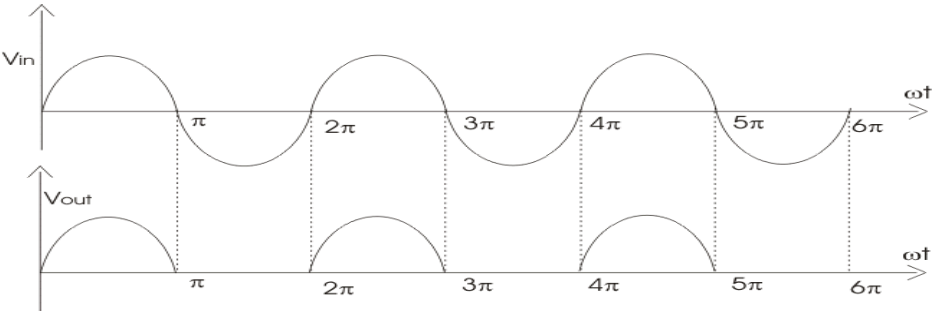

Now, different parameters for **half wave rectifier** is given below

The average of load current (I_{DC}) :

Let, the load current be $i_L = I_m \sin \omega t$,

$$I_{dc} = \frac{1}{2\pi} \int_0^{\pi} I_m \sin \omega t = \frac{I_m}{\pi}$$

Ripple factor of half wave rectifier,

$$Ripple\ factor(r) = \frac{(I_{rms}^2 - I_{dc}^2)}{I_{dc}} = 1.21$$

The rms value of the load current (I_{rms}),

$$I_{rms} = \frac{I_m}{4}$$

4.8 FULL WAVE DIODE RECTIFIER

The diode works only when it is in forward bias, only the current flows through p-n junction diode and output current across the load is found. If two diodes are connected in such a way that one diode conducts during one half of the input voltage and the other one conducts during the next half of the cycle, in a unidirectional can flow through the load during the full cycle of the input voltage. This is known as **full wave rectifier**.

According to the diagram given below a center tapped transformer D_1 , and D_2 are two p-n junction diodes with similar characteristics D_1 conducts for negative half of the output voltage. Thus we get output voltage and the output current for the entire input cycle.

4.8.1 Circuit Diagram of Full Wave Diode Rectifier

The circuit diagram of the **full wave diode rectifier** given below,

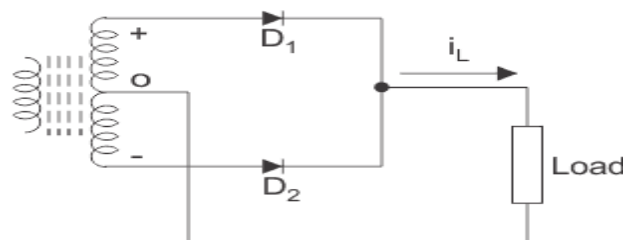

Full wave rectification can also be achieved using a bridge rectifier which is made of four diodes.

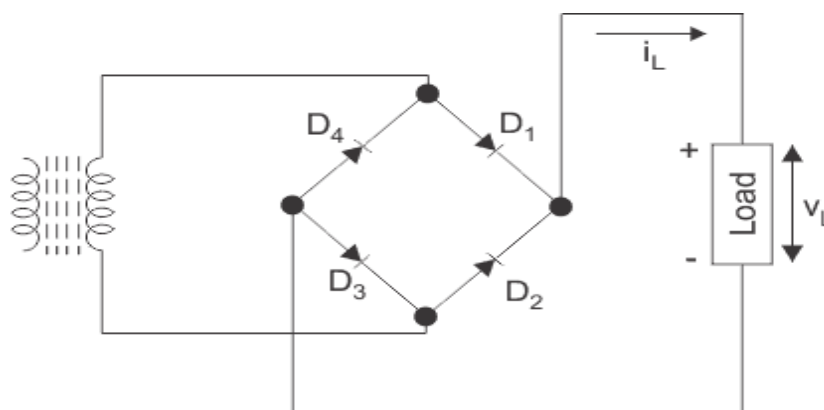

According to the figure, when D_1 and D_3 are forward biased, they conduct but D_2 and D_4 and on D_1 and D_3 are reverse biased in both cases load current in the same direction.

Bridge rectifier has several advantages over simple full wave rectifier. Its performance and efficiency is better than that of the simple full time rectifier.

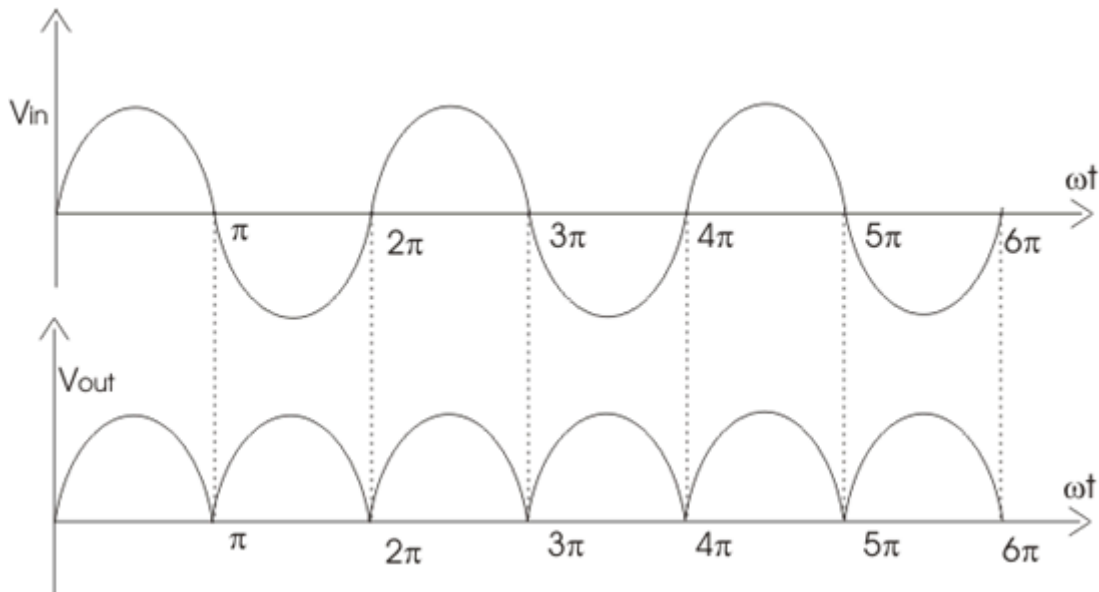

Now, different parameters for **half wave rectifier** is given below

The average of load current (I_{dc}) : Let, the load current be $i_L = I_m \sin \omega t$

$$I_{dc} = \frac{1}{\pi} \int_0^{\pi} I_m \sin \omega t = \frac{2I_m}{\pi}$$

Ripple factor of half wave rectifier,

$$\text{Ripple factor}(r) = \frac{(I_{rms}^2 - I_{dc}^2)^{\frac{1}{2}}}{I_{dc}} = 0.482$$

$$\text{Here, } I_{rms} = \frac{I_m}{\sqrt{2}}$$

HALF WAVE RECTIFIERS

Rectifiers are the circuits used to convert alternating current (AC) into direct current (DC). Half-Wave Rectifiers are designed using a diode (D) and a load resistor (R_L) as shown in Figure 1. In these rectifiers, only one-half of the input waveform is obtained at the output i.e. the output will comprise of either positive pulses or the negative pulses only. The polarity of the output voltage so obtained (across R_L) depends on the direction of the diode used in the circuit of half-wave rectifier. This is evident from the figure as Figure 1a shows the output waveform consisting of only positive pulses while the Figure 1b has only negative pulses in its output waveform.

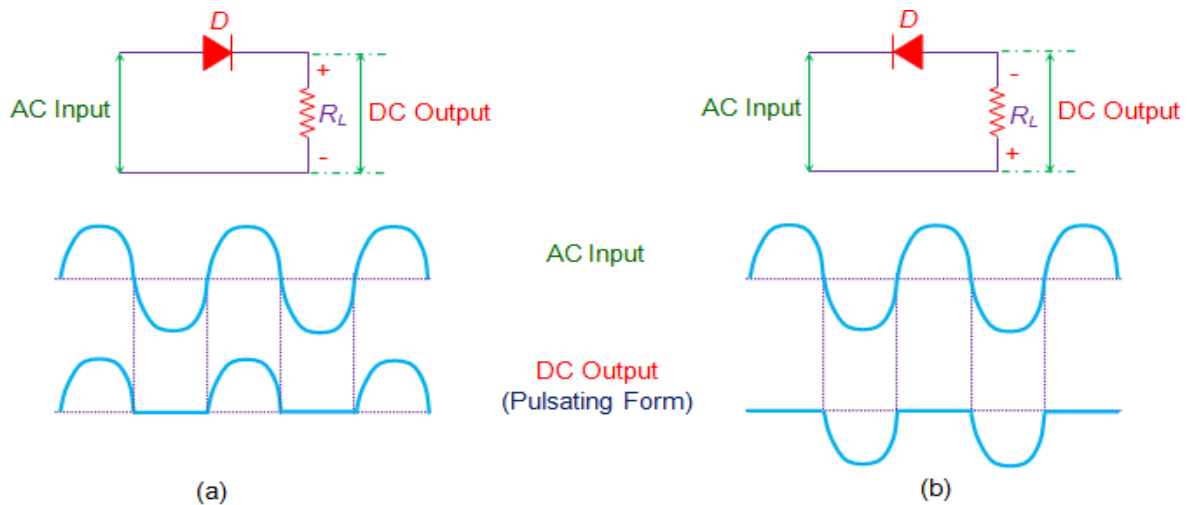

Figure 1 Half Wave Rectifier with Input and Output Waveforms

This is because, in Figure 1a the diode gets forward biased only during the positive pulse of the input which causes the current to flow across R_L , producing the output voltage.

Further for the same case, if the input pulse becomes negative, then the diode will be reverse biased and hence there will be no current flow and no output voltage. Similarly for the circuit shown in Figure 1b, the diode will be forward biased only when the input pulse is negative, and thus the output voltage will contain only the negative pulses. Further it is to be noted that the input to the half-wave rectifier can be supplied even via the transformer. This is advantageous as the transformer provides isolation from the power line as well as helps in obtaining the desired level of DC voltage. Next, one can connect a capacitor across the resistor in the circuit of half wave rectifier to obtain a smoother DC output (Figure 2). Here the capacitor charges through the diode D during the positive pulse of the input while it discharges through the load resistor R_L when the input pulse will be negative. Thus the output waveform of such a rectifier will have ripples in it as shown in the figure.

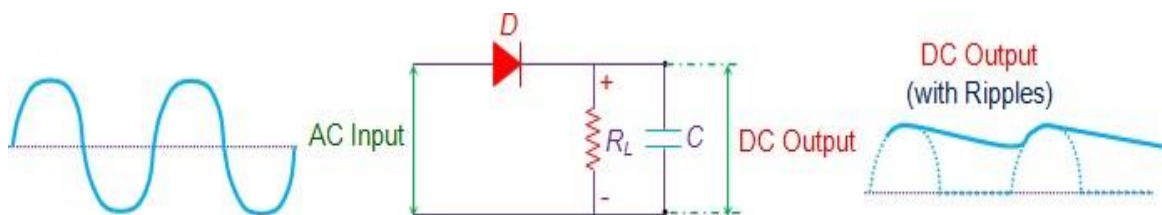

Figure 2 Half-Wave Rectifier with a RC Filter

Different parameters associated with the half wave rectifiers are

1. **Peak Inverse Voltage (PIV):** This is the maximum voltage which should be withstood by the diode under reverse biased condition and is equal to the peak of the input voltage, V_m .
2. **Average Voltage:** This is the DC content of the voltage across the load and is given by V_m/π . Similarly DC current is given as I_m/π , where I_m is the maximum value of the current.
3. **Ripple Factor (r):** It is the ratio of root mean square (rms) value of AC component to the DC component in the output and is given by

$$r = \sqrt{\left(\frac{V_{rms}}{V_{DC}}\right)^2 - 1}$$

Further, for half-wave rectifier, rms voltage is given as $V_m/2$ which results in the ripple factor of 1.21.

4. **Efficiency:** It is the ratio of DC output power to the AC input power and is equal to 40.6%.
5. **Transformer Utilization Factor:** It is the ratio of DC power delivered to the load to the AC rating of the transformer secondary and is equal to 0.287.

6. **Form Factor:** This is the ratio of rms value to the average value and is thus equal to 1.57 for half-wave rectifier.
7. **Peak Factor:** It is the ratio of peak value to the rms value and is equal to 2.

Half wave rectifiers are advantageous as they are cheap, simple and easy to construct. These are quite rarely used as they have high ripple content in their output. However they can be used in non-critical applications like those of charging the battery. They are also less preferred when compared to other rectifiers as they have low output power, low rectification efficiency and low transformer utilization factor. In addition, if AC input is fed via the transformer, then it might get saturated which in turn results in magnetizing current, hysteresis loss and/or result in the generation of harmonics. Lastly it is important to note that the explanation provided here applies only for the case where the diode is ideal. Although for a practical diode, the basic working remains the same, one will have to consider the voltage drop across the diode as well as its reverse saturation current into consideration during the analysis.

FULL WAVE RECTIFIERS

The circuits which convert the input alternating current (AC) into direct current (DC) are referred to as rectifiers. If such rectifiers rectify both the positive as well as negative pulses of the input waveform, then they are called Full-Wave Rectifiers. Figure 1 shows such a rectifier designed using a multiple winding transformer whose secondary winding is equally divided into two parts with a provision for the connection at its central point (and thus referred to as the centre-tapped transformer), two diodes (D_1 and D_2) and a load resistor (R_L). Here the AC input is fed to the primary winding of the transformer while an arrangement of diodes and the load resistor which yields the DC output, is made across its secondary terminals.

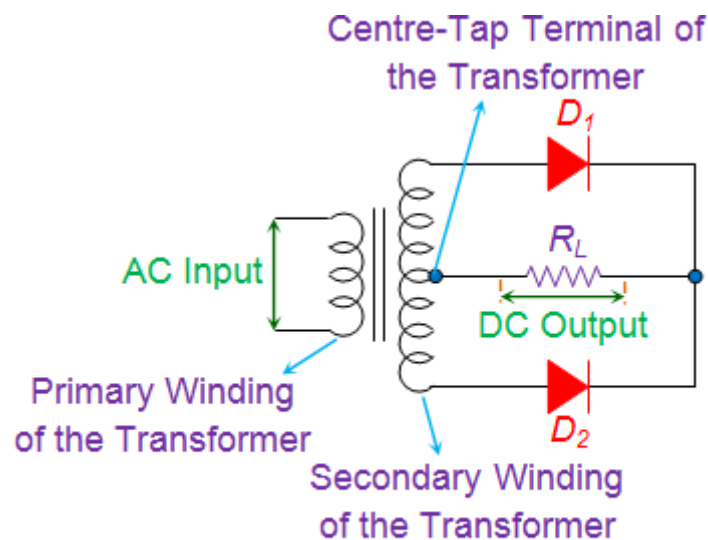

Figure 1 Full Wave Rectifier

The circuit can be analyzed by considering its working during the positive and the negative input pulses separately.

Figure 2a shows the case where the AC pulse is positive in nature i.e. the polarity at the top of the primary winding is positive while its bottom will be negative in polarity. This causes the top part of the secondary winding to acquire a positive charge while the common centre-tap terminal of the transformer will become negative.

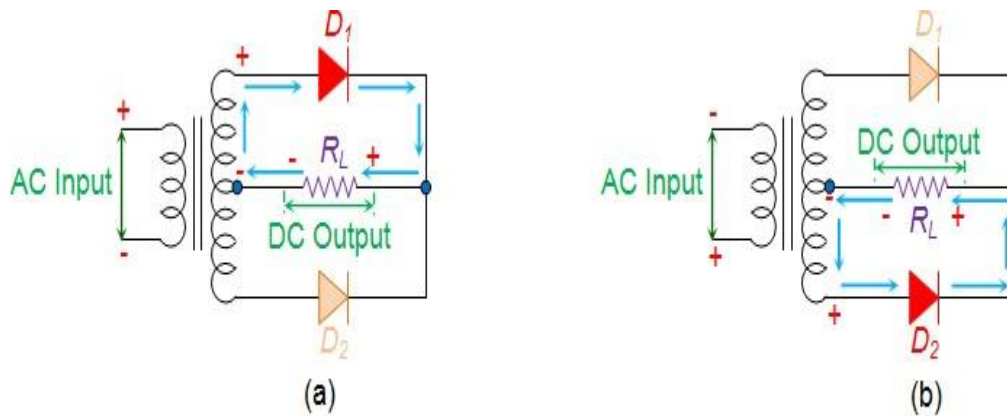

Figure 2 Conduction Path of Full Wave Rectifier for (a) Positive Input Pulse (b) Negative Input Pulse

This causes the diode D_1 to be forward biased which in turn causes the flow of current through R_L along the direction shown in Figure 2a. However at the same time, diode D_2 will be reverse biased and hence acts like an open circuit. This causes the appearance of positive pulse across the R_L , which will be the DC output. Next, if the input pulse becomes negative in nature, then the top and the bottom of the primary winding will acquire the negative and the positive polarities respectively. This causes the bottom of the secondary winding to become positive while its centre-tapped terminal will become negative. Thus the diode D_2 gets forward biased while the D_1 will get reverse biased which allows the flow of current as shown in the Figure 2b. Here the most important thing to note is the fact that the direction in which the current flows via R_L will be identical in either case (both for positive as well as for negative input pulses). Thus we get the positive output pulse even for the case of negative input pulse (Figure 3), which indicates that both the half cycles of the input AC are rectified.

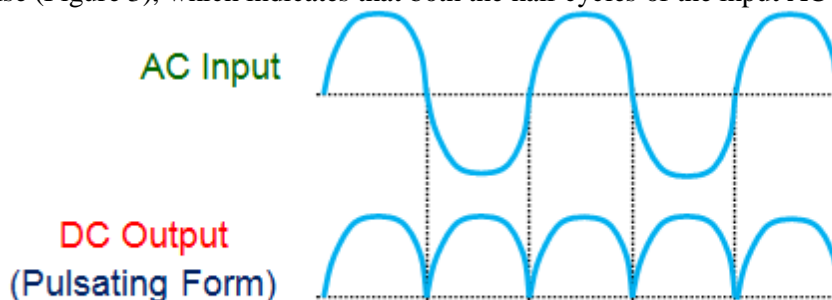

Figure 3 Input and Output Waveforms of Full Wave Rectifier

Such circuits are referred to as (i) Centre-Tapped **Full Wave Rectifiers** as they use a centre-tapped transformer, (ii) Two-Diode Full-Wave Rectifiers because of the use of two diodes and/or (iii) Bi-Phase Circuits due to the fact that in these circuits, the output voltage will be the phasor addition of the voltages developed across the load resistor due to two individual diodes, where each of them conducts only for a particular half-cycle. However as evident from Figure 3, the output of the rectifier is not pure DC but pulsating in nature, where the frequency of the output waveform is seen to be double of that at the input. In order to smoothen this, one can connect a capacitor across the load resistor as shown by the Figure 4. This causes the capacitor to charge via the diode D_1 as long as the input positive pulse increases in its magnitude. By the time the input pulse reaches the positive maxima, the capacitor would have charged to the same magnitude. Next, as long as the input positive pulse keeps

decreasing, the capacitor tries to hold the charge acquired (being an energy-storage element).

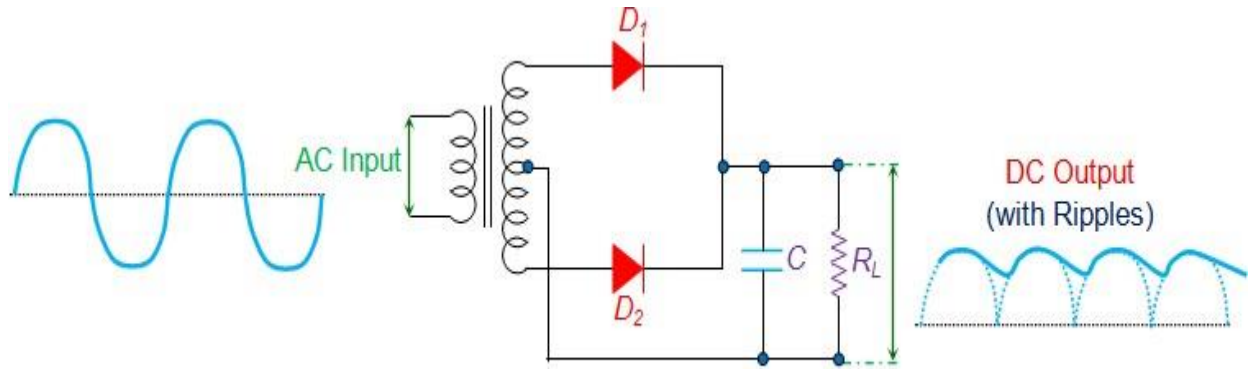

Figure 4 Full-Wave Rectifier with a RC Filter

However there will be voltage-loss as some amount of charge gets lost through the path provided by the load resistor (nothing but discharging phenomenon). Further, as the input pulse starts to go low to reach the negative maxima, the capacitor again starts to charge via the path provided by the diode D_2 and acquires an almost equal voltage but with opposite polarity. Next, as the input voltage starts to move towards 0V, the capacitor slightly discharges via R_L . This charge-discharge cycle of the capacitor causes the ripples to appear in the output waveform of the full-wave rectifier with RC filter as shown in Figure 4.

Different parameters and their values for the centre-tapped full-wave rectifiers are

1. **Peak Inverse Voltage (PIV):** This is the maximum voltage which occurs across the diodes when they are reverse biased. Here it will be equal to twice the peak of the input voltage, $2V_m$.
2. **Average Voltage:** It is the DC voltage available across the load and is equal to $2V_m/\pi$. The corresponding DC current will be $2I_m/\pi$, where I_m is the maximum value of the current.
3. **Ripple Factor (r):** This is the ratio of the root mean square (rms) value of AC component to the dc component at the output. It is given by

$$r = \sqrt{\left(\frac{V_{rms}}{V_{DC}}\right)^2 - 1}$$

and will be equal to 0.482 as the rms voltage for a full-wave rectifier is given as

$$\frac{V_m}{\sqrt{2}}$$

4. **Efficiency:** This is the ratio of DC output power to the AC input power and is equal to 81.2%.
5. **Transformer Utilization Factor (TUF):** This factor is expressed as the ratio of DC power delivered to the load to the AC rating of the transformer secondary. For the full-wave rectifier this will be 0.693.
6. **Form Factor:** This is the ratio of rms value to the average value and is equal to 1.11.
7. **Peak Factor:** It is the ratio of peak value to the rms value and is equal to $\sqrt{2}$ for the full-wave rectifiers.

Further it is to be noted that the two-diode full-wave rectifier shown in Figure 1 is costly and bulky in size as it uses the complex centre-tapped transformer in its design. Thus one may resort to another type of full-wave rectifier called Full-Wave Bridge Rectifier (identical to Bridge Rectifier) which might or might not involve the transformer (even if used, will not be as complicated as a centre-tap one). It also offers higher TUF and higher PIV which makes it ideal for high power applications. However it is to be noted that the full wave bridge rectifier uses four diodes instead of two, which in turn increases the magnitude of voltage drop across the diodes, increasing the heating loss. **Full wave rectifiers** are used in general power supplies, to charge a battery and to provide power to the devices like motors, LEDs, etc. However due to the ripple content in the output waveform, they are not

preferred for audio applications. Further these are advantageous when compared to half-wave rectifiers as they have higher DC output power, higher transformer utilization factor and lower ripple content, which can be made more smoother by using π -filters. All these merits mask-up its demerit of being costly in comparison to the half-wave rectifiers due to the use of increased circuit elements. At last, it is to be noted that the explanation provided here considers the diodes to be ideal in nature. So, in case of practical diodes, one will have to consider the voltage drop across the diode, its reverse saturation current and other diode characteristics into account and reanalyze the circuit. Nevertheless the basic working remains the same.

4.10 BRIDGE RECTIFIERS

Bridge Rectifiers are the circuits which convert alternating current (AC) into direct current (DC) using the diodes arranged in the bridge circuit configuration. They usually comprise of four or more number of diodes which cause the output generated to be of the same polarity irrespective of the polarity at the input. Figure 1 shows such a bridge rectifier composed of four diodes D_1, D_2, D_3 and D_4 in which the input is supplied across two terminals A and B in the figure while the output is collected across the load resistor R_L connected between the terminals C and D.

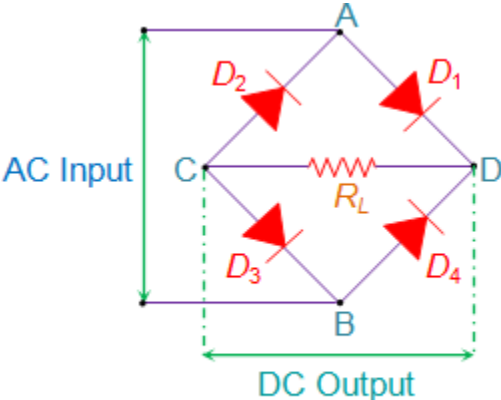

Figure 1 Bridge Rectifier

Now consider the case wherein the positive pulse appears at the AC input i.e. the terminal A is positive while the terminal B is negative. This causes the diodes D_1 and D_3 to get forward biased and at the same time, the diodes D_2 and D_4 will be reverse biased.

As a result, the current flows along the short-circuited path created by the diodes D_1 and D_3 (considering the diodes to be ideal), as shown by Figure 2a. Thus the voltage developed across the load resistor R_L will be positive towards the end connected to terminal D and negative at the end connected to the terminal C.

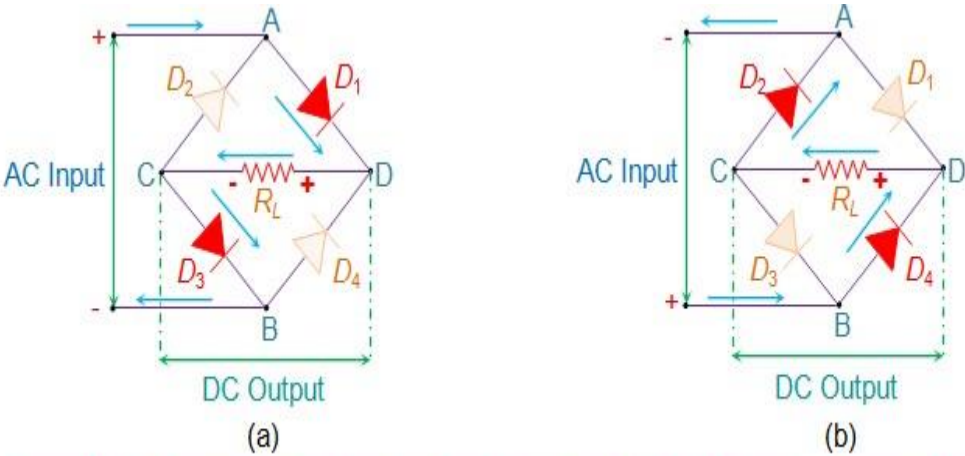

Figure 2 Current Path Through the Bridge Rectifier for (a) Positive half-cycle (b) Negative Half-Cycle

Next if the negative pulse appears at the AC input, then the terminals A and B are negative and positive respectively. This forward biases the diodes D_2 and D_4 , while reverse biasing D_1 and D_3 which causes the current to flow in the direction shown by Figure 2b. At this instant, one has to note that the polarity of the voltage developed across R_L is identical to that produced when the incoming AC pulse was positive in nature. This means that for both positive and negative pulse, the output of the bridge rectifier will be identical in polarity as shown by the wave forms in Figure 3.

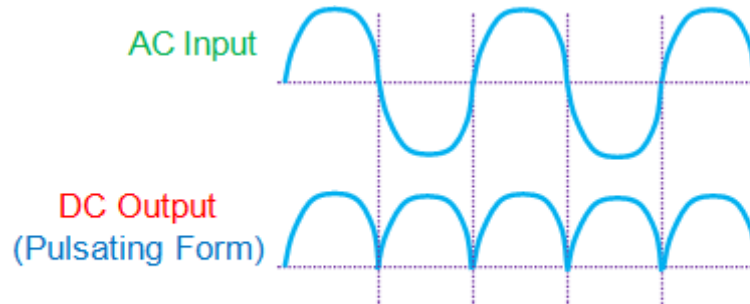

Figure 3 Input-Output Waveforms of a Bridge Rectifier

However it is to be noted that the bridge rectifier's DC will be pulsating in nature. In order to obtain pure form of DC, one has to use capacitor in conjunction with the bridge circuit (Figure 4).

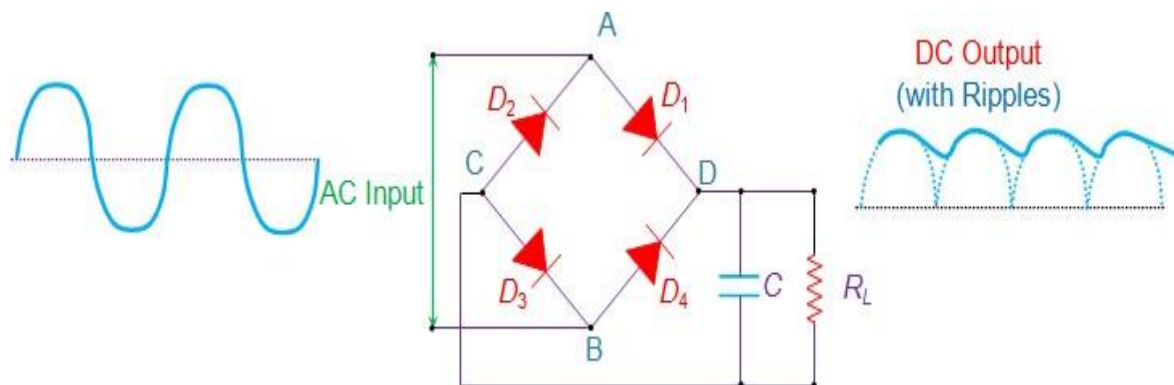

Figure 4 Bridge Rectifier with a RC Filter

In this design, the positive pulse at the input causes the capacitor to charge through the diodes D_1 and D_3 . However as the negative pulse arrives at the input, the charging action of the capacitor ceases and it starts to discharge via R_L . This results in the generation of DC output which will have ripples in it as shown in the figure. This ripple factor is defined as the ratio of AC component to the DC component in the output voltage. In addition, the mathematical expression for the ripple voltage is given by the equation

$$V_r = \frac{I_l}{fC}$$

Where, V_r represents the ripple voltage.

I_l represents the load current.

f represents the frequency of the ripple which will be twice the input frequency.

C is the Capacitance.

Further, the **bridge rectifiers** can be majorly of two types, viz., Single-Phase Rectifiers and Three-Phase Rectifiers. In addition, each of these can be either Uncontrolled or Half-Controlled or Full-Controlled. Bridge rectifiers for a particular application are selected by considering the load current requirements. These bridge rectifiers are quite advantageous as they can be constructed with or without a transformer and are suitable for high voltage applications. However here two diodes will be conducting for every half-cycle and thus the voltage drop across the diodes will be higher. Lastly one has to note that apart from converting AC to DC, **bridge rectifiers** are also used to detect the amplitude of modulated radio signals and to supply polarized voltage for welding applications.

UNIT V

BIPOLAR JUNCTION TRANSISTOR AND APPLICATIONS

INTRODUCTION

The transistor was invented in 1947 by John Bardeen, Walter Brattain and William Shockley at Bell Laboratory in America. A transistor is a semiconductor device, commonly used as an Amplifier or an electrically Controlled Switch.

There are two types of transistors:

- 1) Unipolar Junction Transistor
- 2) Bipolar Junction Transistor

In Unipolar transistor, the current conduction is only due to one type of carriers i.e., majority charge carriers. The current conduction in bipolar transistor is because of both the types of charge carriers i.e., holes and electrons. Hence it is called as Bipolar Junction Transistor and it is referred to as BJT.

BJT is a semiconductor device in which one type of semiconductor material is sandwiched between two opposite types of semiconductor i.e., an n-type semiconductor is sandwiched between two p-type semiconductors or a p-type semiconductor is sandwiched between two n-type semiconductor.

Hence the BJTs are of two types. They are:

- 1) n-p-n Transistor
- 2) p-n-p Transistor

The two types of BJTs are shown in the figure below.

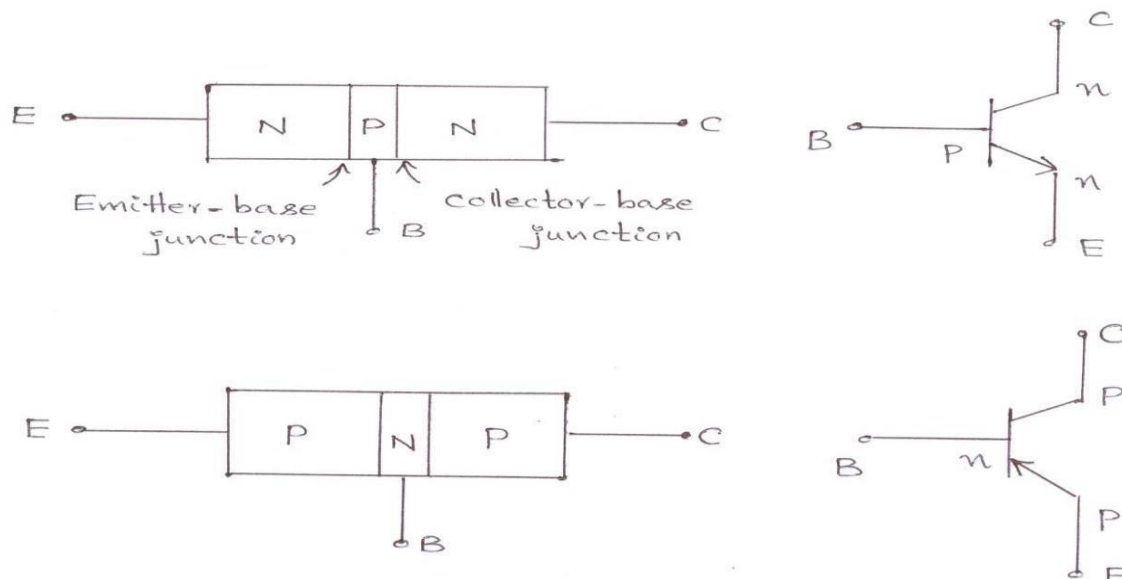

The arrow head represents the conventional current direction from p to n. Transistor has three terminals.

- 1) Emitter
- 2) Base
- 3) Collector

Transistor has two p-n junctions. They are:

- 1) Emitter-Base Junction
- 2) Collector-Base Junction

Emitter: Emitter is heavily doped because it is to emit the charge carriers.

Base: The charge carriers emitted by the emitter should reach collector passing through the base. Hence base should be very thin and to avoid recombination, and to provide more collector current base is lightly doped.

Collector: Collector has to collect the most of charge carriers emitted by the emitter. Hence the area of cross section of collector is more compared to emitter and it is moderately doped.

Transistor can be operated in three regions.

- 1) Active region.
- 2) Saturation region.
- 3) Cut-Off region.

Active Region: For the transistor to operate in active region base to emitter junction is forward biased and collector to base junction is reverse biased.

Saturation Region: Transistor to be operated in saturation region if both the junctions i.e., collector to base junction and base to emitter junction are forward biased.

Cut-Off Region: For the transistor to operate in cut-off region both the junctions i.e., base to emitter junction and collector to base junction are reverse biased.

Transistor can be used as

- 1) Amplifier
- 2) Switch

For the transistor to act as an amplifier, it should be operated in active region. For the transistor to act as a switch, it should be operated in saturation region for ON state, and cut-off region for OFF state.

TRANSISTOR OPERATION:

Working of a n-p-n transistor:

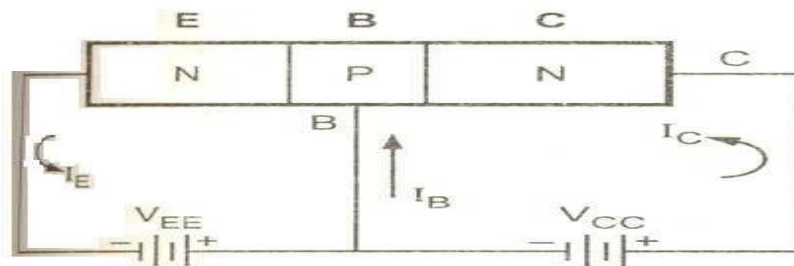

The n-p-n transistor with base to emitter junction forward biased and collector base junction reverse biased is as shown in figure.

As the base to emitter junction is forward biased the majority carriers emitted by the n type emitter i.e., electrons have a tendency to flow towards the base which constitutes the emitter

Current I_E . As the base is p-type there is chance of recombination of electrons emitted by the emitter with the holes in the p-type base. But as the base is very thin and lightly doped only few electrons emitted by the n-type emitter less than 5% combines with the holes in the p-type base, the remaining more than 95% electrons emitted by the n-type emitter cross over into the collector region constitute the collector current. The current distributions are as shown in fig $I_E = I_B + I_C$

Working of a p-n-p transistor:

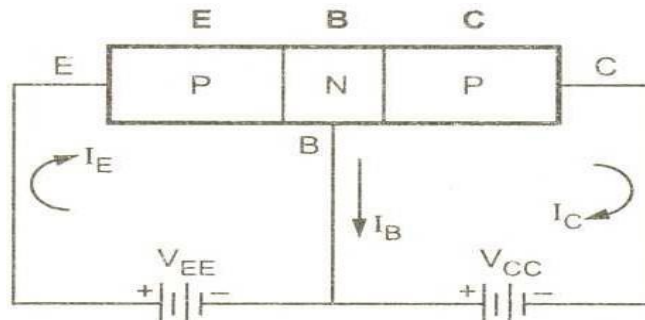

The p-n-p transistor with base to emitter junction is forward biased and collector to base junction reverse biased is as show in figure. As the base to emitter junction is forward biased the majority carriers emitted by the type emitter i.e., holes have a tendency to flow towards the base which constitutes the emitter current I_E . As the base is n-type there is a chance of recombination of holes emitted by the emitter with the electrons in the n-type base. But as the base us very thin and lightly doped only few electrons less than 5% combine with the holes emitted by the p-type emitter, the

remaining 95% charge carriers cross over into the collector region to constitute the collector current. The current distributions are shown in figure.

$$I_E = I_B + I_C$$

Current components in a transistor:

The figure below shows the various current components which flow across the forward biased emitter junction and reverse-biased collector junction in P-N-P transistor

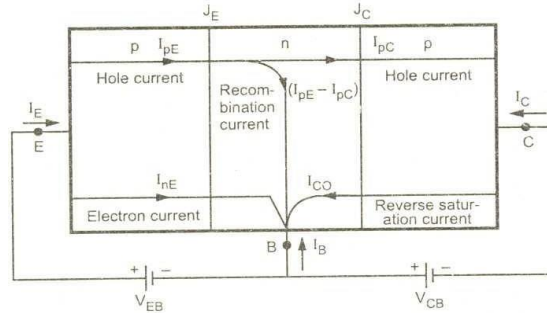

Figure. Current components in a transistor with forward-biased emitter and reverse-biased Collector junctions. The emitter current consists of the following two parts:

- 1) Hole current I_{pE} constituted by holes (holes crossing from emitter into base).
- 2) Electron current I_{nE} constituted by electrons (electrons crossing from base into the emitter).

Therefore, Total emitter current $I_E = I_{pE}$ (majority) + I_{nE} (Minority)

The holes crossing the emitter base junction J_E and reaching the collector base junction J_C constitutes collector current I_{pC} . Not all the holes crossing the emitter base junction J_E reach collector base junction J_C because some of them combine with the electrons in the n-type base. Since base width is very small, most of the holes cross the collector base junction J_C and very few recombine, constituting the base current $(I_{pE} - I_{pC})$.

When the emitter is open-circuited, $I_E=0$, and hence $I_{pC}=0$. Under this condition, the base and collector together current I_C equals the reverse saturation current I_{CO} , which consists of the following two parts: I_{PCO} caused by holes moving across J_C from N-region to P-region.

I_{nCO} caused by electrons moving across J_C from P-region to N-region. $I_{CO} = I_{nCO} + I_{pCO}$

In general,

$$I_C = I_{nC} + I_{pC}$$

Thus for a P-N-P transistor,

$$I_E = I_B + I_C$$

TRANSISTOR CIRCUIT CONFIGURATIONS:

Following are the three types of transistor circuit configurations:

- 1) Common-Base (CB)
- 2) Common-Emitter (CE)
- 3) Common-Collector (CC)

Here the term 'Common' is used to denote the transistor lead which is common to the input and output circuits. The common terminal is generally grounded.

It should be remembered that regardless the circuit configuration, the emitter is always forward-biased while the collector is always reverse-biased.

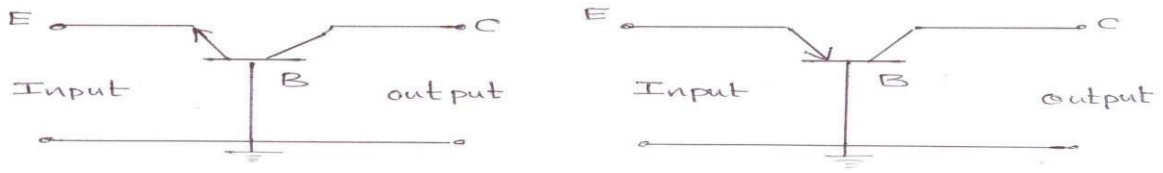

Fig. Common – Base configuration

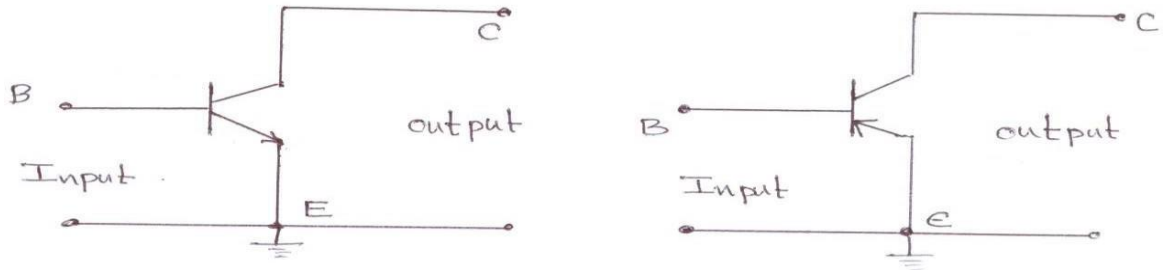

Fig. Common – emitter configuration

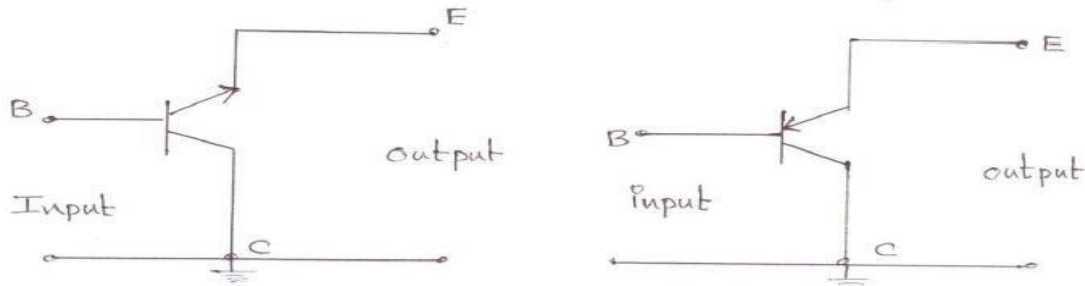

Fig. Common – Collector configuration

Common – Base (CB) configurations:

In this configuration, the input signal is applied between emitter and base while the output is taken from collector and base. As base is common to input and output circuits, hence the name common-base configuration. Figure show the common-base P-N-P transistor circuit.

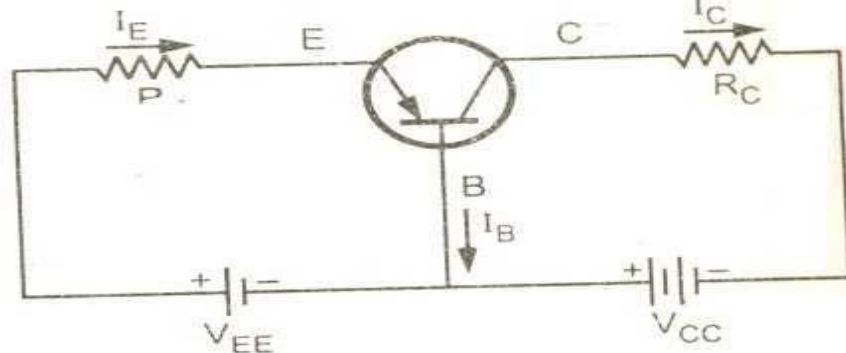

Fig. Common – base PNP transistor amplifier.

Current Amplification Factor (α) :

When no signal is applied, then the ratio of the collector current to the emitter current is called dc alpha (α_{dc}) of a transistor.

$$\alpha_{dc} = \frac{-I_C}{I_E}, \dots\dots\dots (1)$$

(Negative sign signifies that I_E flows into transistor while I_C flows out of it). ' α ' of a transistor is a measure of the quality of a transistor. Higher is the value of ' α ', better is the transistor in the sense that collector current approaches the emitter current. By considering only magnitudes of the currents, $I_C = \alpha I_E$ and hence $I_B = I_E - I_C$

Therefore,

$$I_B = I_E - \alpha I_E = I_E(1 - \alpha) \dots\dots\dots (2)$$

When signal is applied, the ratio of change in collector current to the change in emitter current at constant collector-base voltage is defined as current amplification factor,

$$\alpha_{dc} = - \frac{\Delta I_C}{\Delta I_E} \dots\dots\dots (3)$$

For all practical purposes, $\alpha_{dc} = \alpha_{ac} = \alpha$ and practical values in commercial transistors range from 0.9 to 0.99.

Total Collector Current:

The total collector current consists of the following two parts

- i) αI_E , current due to majority carriers
- ii) I_{CBO} , current due to minority carriers

\ Total collector current $I_C = \alpha I_E + I_{CBO} \dots\dots\dots (4)$

The collector current can also be expressed as $I_C = \alpha (I_B + I_C) + I_{CBO}$ ($Q I_E = I_B + I_C$)

$$\Rightarrow I_C(1 - \alpha) = \alpha I_B + I_{CBO}$$

$$\Rightarrow I_C = \left(\frac{\alpha}{1 - \alpha}\right) I_B + \left(\frac{1}{1 - \alpha}\right) I_{CBO} \dots (5)$$

COMMON-EMITTER (CE) CONFIGURATION:

In this configuration, the input signal is applied between base and emitter and the output is taken from collector and emitter. As emitter is common to input and output circuits, hence the name common emitter configuration.

Figure shows the common-emitter P-N-P transistor circuit.

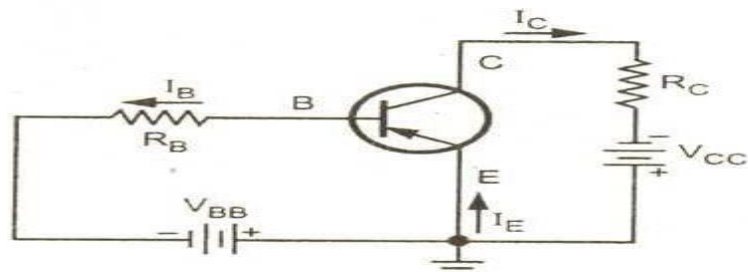

Fig. Common-Emitter PNP transistor amplifier.

Current Amplification Factor (β):

When no signal is applied, then the ratio of collector current to the base current is called dc beta (β_{dc}) of a transistor.

$$\beta_{dc} = \beta = \frac{I_C}{I_B} \dots\dots\dots (1)$$

When signal is applied, the ratio of change in collector current to the change in base current is defined as base current amplification factor. Thus,

$$\beta_{dc} = \beta = \frac{\Delta I_C}{\Delta I_B} \dots\dots\dots (2)$$

From equation (1), $I_C = \beta I_B$

Almost in all transistors, the base current is less than 5% of the emitter current. Due to this fact, 'β' ranges from 20 to 500. Hence this configuration is frequently used when appreciable current gain as well as voltage gain is required.

Total Collector Current:

The Total collector current $I_C = \beta I_B + I_{CEO} \dots\dots\dots (3)$

Where I_{CEO} is the leakage current.

But, we have, $I_C = \left(\frac{\alpha}{1-\alpha}\right)I_B + \left(\frac{1}{1-\alpha}\right)I_{CBO} \dots\dots\dots (4)$

Comparing equations (3) and (4), we get

$$\beta = \frac{\alpha}{1-\alpha} \text{ and } I_{CEO} = \frac{1}{1-\alpha}I_{CBO} \dots\dots\dots (5)$$

Relation between α and β:

We know that $\alpha = \frac{I_C}{I_E}$ and $\beta = \frac{I_C}{I_B}$

$$I_E = I_B + I_C \quad (\text{or}) \quad I_B = I_E - I_C$$

Now
$$\beta = \frac{I_C}{I_E - I_C} = \frac{\frac{I_C}{I_E}}{1 - \frac{I_C}{I_E}} = \frac{\alpha}{1-\alpha} \dots\dots\dots (6)$$

$$\Rightarrow \beta(1-\alpha) = \alpha \quad (\text{or}) \quad \beta = \alpha(1+\beta)$$

$$\Rightarrow \alpha = \frac{\beta}{1+\beta} \dots\dots\dots (7)$$

It can be seen that $1-\alpha = \frac{1}{1+\beta} \dots\dots\dots (8)$

COMMON – COLLECTOR (CC) CONFIGURATION:

In this configuration, the input signal is applied between base and collector and the output is taken from the emitter. As collector is common to input and output circuits, hence the name common collector configuration. Figure shows the common collector PNP transistor circuit.

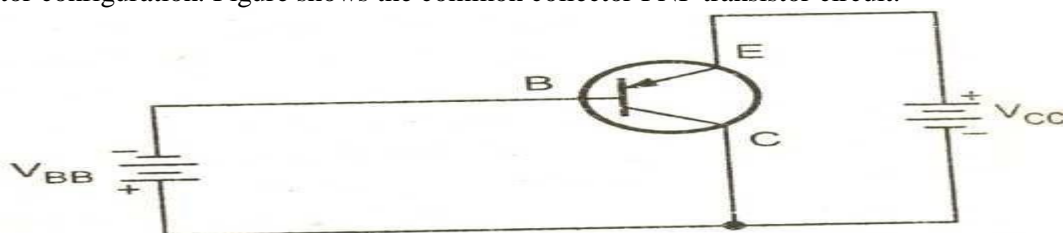

Fig. Common collector PNP transistor amplifier.

Current Amplification Factor γ):

When no signal is applied, then the ratio of emitter current to the base current is called as dc gamma (γ_{dc}) of the transistor.

$$\gamma_{dc} = \gamma = \frac{I_E}{I_B} \dots\dots\dots (1)$$

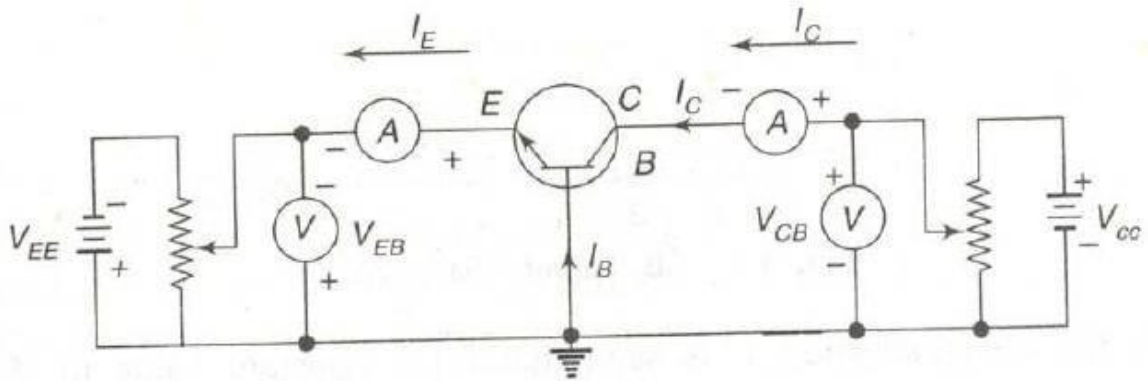

Fig. Circuit to determine CB static characteristics.

INPUT CHARACTERISTICS:

To determine the input characteristics, the collector-base voltage V_{CB} is kept constant at zero volts and the emitter current I_E is increased from zero in suitable equal steps by increasing V_{EB} . This is repeated for higher fixed values of V_{CB} . A curve is drawn between emitter current I_E and emitter-base voltage V_{EB} at constant collector-base voltage V_{CB} .

The input characteristics thus obtained are shown in figure below.

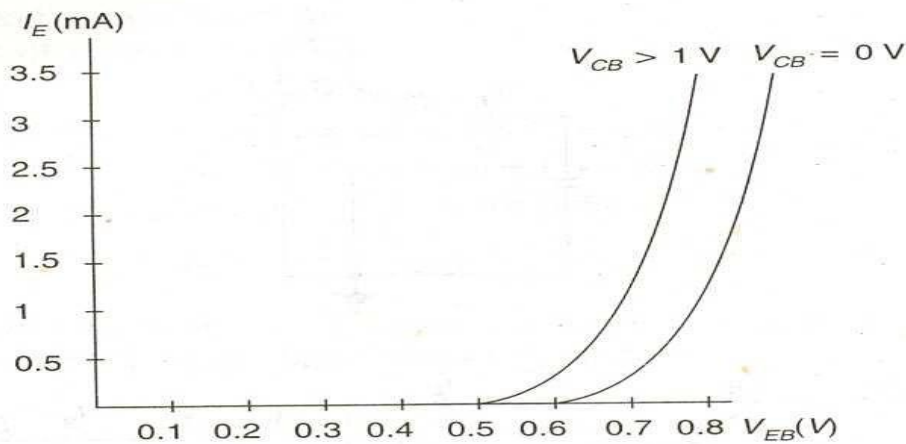
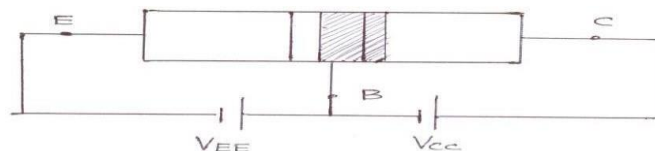

Fig. CB Input characteristics.

Early effect (or) Base – Width modulation:

As the collector voltage V_{CC} is made to increase the reverse bias, the space charge width between collector and base tends to increase, with the result that the effective width of the base decreases. This dependency of base-width on collector-to-emitter voltage is known as Early effect (or) Base-Width modulation.



Thus decrease in effective base width has following consequences:

- i. Due to Early effect, the base width reduces, there is a less chance of recombination of holes with electrons in base region and hence base current I_B decreases.
- ii. As I_B decreases, the collector current I_C increases.
- iii. As base width reduces the emitter current I_E increases for small emitter to base voltage.
- iv. As collector current increases, common base current gain (α) increases.

Punch Through (or) Reach Through:

When reverse bias voltage increases more, the depletion region moves towards emitter junction and effective base width reduces to zero. This causes breakdown in the transistor. This condition is called “Punch Through” condition.

Output Characteristics:

To determine the output characteristics, the emitter current I_E is kept constant at a suitable value by adjusting the emitter-base voltage V_{EB} . Then V_{CB} is increased in suitable equal steps and the collector current I_C is noted for each value of I_E . Now the curves of I_C versus V_{CB} are plotted for constant values of I_E and the output characteristics thus obtained is shown in figure below.

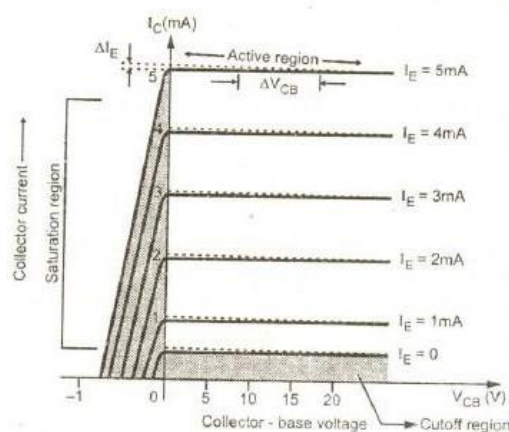

Fig. CB Output characteristics

From the characteristics, it is seen that for a constant value of I_E , I_C is independent of V_{CB} and the curves are parallel to the axis of V_{CB} . Further, I_C flows even when V_{CB} is equal to zero. As the emitter-base junction is forward biased, the majority carriers, i.e., electrons, from the emitter are injected into the base region. Due to the action of the internal potential barrier at the reverse biased collector-base junction, they flow to the collector region and give rise to I_C even when V_{CB} is equal to zero.

Transistor Parameters:

The slope of the CB characteristics will give the following four transistor parameters. Since these parameters have different dimensions, they are commonly known as common base hybrid parameters (or) h-parameters.

i) Input Impedance (h_{ib}):

It is defined as the ratio of change in (input) emitter to base voltage to the change in (input) emitter current with the (output) collector to base voltage kept constant. Therefore,

$$h_{ib} = \frac{\Delta V_{EB}}{\Delta I_E}, V_{CB} \text{ constant}$$

It is the slope of CB input characteristics curve.
The typical value of h_{ib} ranges from 20 Ω to 50 Ω .

ii) Output Admittance (h_{ob}):

It is defined as the ratio of change in the (output) collector current to the corresponding change in the (output) collector-base voltage, keeping the (input) emitter current I_E constant. Therefore,

$$h_{ob} = \frac{\Delta I_C}{\Delta V_{CB}}, I_E \text{ constant}$$

It is the slope of CB output characteristics I_C versus V_{CB} .

The typical value of this parameter is of the order of 0.1 to $10\mu\text{hos}$

iii) Forward Current Gain (h_{fb}):

It is defined as a ratio of the change in the (output) collector current to the corresponding change in the (input) emitter current keeping the (output) collector voltage V_{CB} constant. Hence,

$$h_{fb} = \frac{\Delta I_C}{\Delta I_E}, V_{CB} \text{ constant}$$

It is the slope of I_C versus I_E curve. Its typical value varies from 0.9 to 1.0.

iv) Reverse Voltage Gain (h_{rb}):

It is defined as a ratio of the change in the (input) emitter voltage and the corresponding change in (output) collector voltage with constant (input) emitter current, I_E . Hence,

$$h_{rb} = \frac{\Delta V_{EB}}{\Delta V_{CB}}, I_E \text{ constant.}$$

It is the slope of V_{EB} versus V_{CB} curve. Its typical value is of the order of 10^{-5} to 10^{-4}

CHARACTERISTICS OF COMMON-EMITTER CIRCUIT:

The circuit diagram for determining the static characteristic curves of the an N-P-N transistor in the common emitter configuration is shown in figure below.

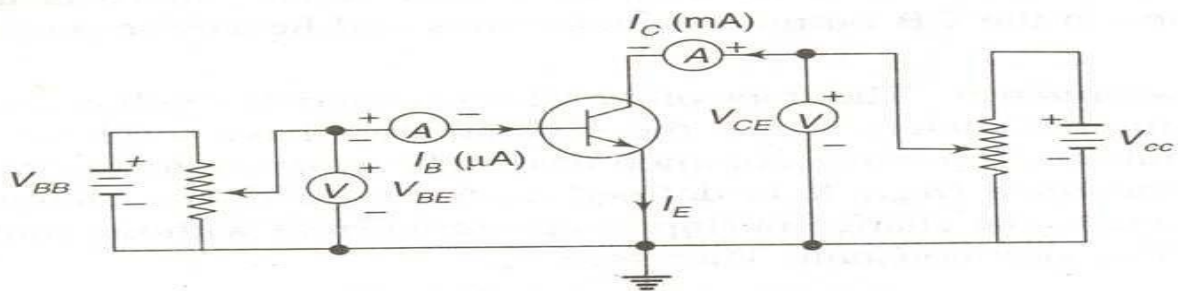

Fig. Circuit to determine CE Static characteristics.

Input Characteristics:

To determine the input characteristics, the collector to emitter voltage is kept constant at zero volts and base current is increased from zero in equal steps by increasing V_{BE} in the circuit. The value of V_{BE} is noted for each setting of I_B . This procedure is repeated for higher fixed values of V_{CE} , and the curves of I_B versus V_{BE} are drawn.

The input characteristics thus obtained are shown in figure below.

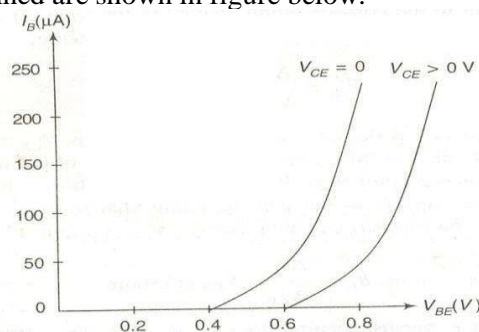

Fig. CE Input Characteristics.

When $V_{CE}=0$, the emitter-base junction is forward biased and the junction behaves as a forward biased diode. When V_{CE} is increased, the width of the depletion region at the reverse biased collector-

base junction will increase. Hence the effective width of the base will decrease. This effect causes a decrease in the base current I_B . Hence, to get the same value of I_B as that for $V_{CE}=0$, V_{BE} should be increased. Therefore, the curve shifts to the right as V_{CE} increases.

Output Characteristics:

To determine the output characteristics, the base current I_B is kept constant at a suitable value by adjusting base-emitter voltage, V_{BE} . The magnitude of collector-emitter voltage V_{CE} is increased in suitable equal steps from zero and the collector current I_C is noted for each setting of V_{CE} . Now the curves of I_C versus V_{CE} are plotted for different constant values of I_B . The output characteristics thus obtained are shown in figure below.

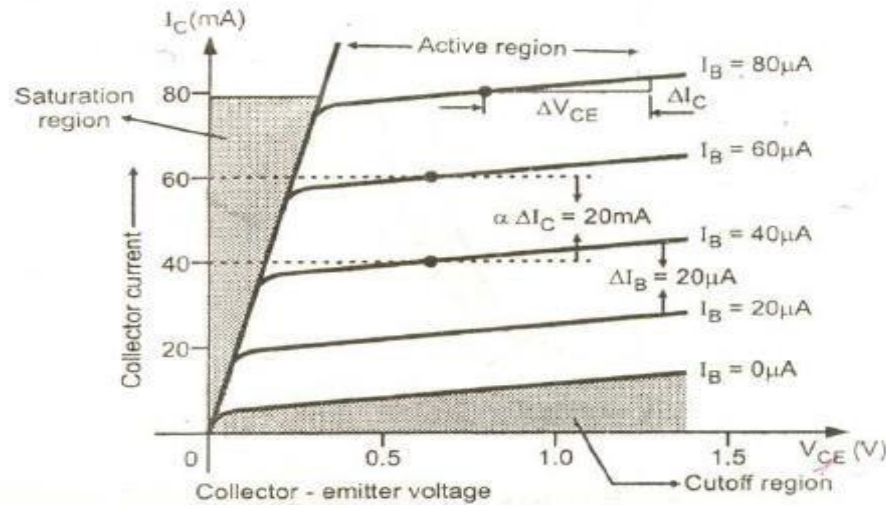

Fig. CE Output characteristics

The output characteristics of common emitter configuration consist of three regions: Active, Saturation and Cut-off regions.

Active Region:

The region where the curves are approximately horizontal is the “Active” region of the CE configuration. In the active region, the collector junction is reverse biased. As V_{CE} is increased, reverse bias increases. This causes depletion region to spread more in base than in collector, reducing the changes of recombination in the base. This increases the value of α . This Early effect causes collector current to rise more sharply with increasing V_{CE} in the active region of output characteristics of CE transistor.

Saturation Region:

If V_{CE} is reduced to a small value such as 0.2V, then collector-base junction becomes forward biased, since the emitter-base junction is already forward biased by 0.7V. The input junction in CE configuration is base to emitter junction, which is always forward biased to operate transistor in active region. Thus input characteristics of CE configuration are similar to forward characteristics of p-n junction diode. When both the junctions are forward biased, the transistor operates in the saturation region, which is indicated on the output characteristics. The saturation value of V_{CE} , designated $V_{CE(Sat)}$, usually ranges between 0.1V to 0.3V.

Cut-Off Region:

When the input base current is made equal to zero, the collector current is the reverse leakage current I_{CEO} . Accordingly, in order to cut off the transistor, it is not enough to reduce $I_B=0$. Instead, it is necessary to reverse bias the emitter junction slightly. We shall define cut off as the condition where the collector current is equal to the reverse saturation current I_{CO} and the emitter current is zero.

TRANSISTOR PARAMETERS:

The slope of the CE characteristics will give the following four transistor parameters. Since these parameters have different dimensions, they are commonly known as Common emitter hybrid parameters (or) h-parameters.

i) Input Impedance (h_{ie}):

It is defined as the ratio of change in (input) base voltage to the change in (input) base current with the (output) collector voltage (VCE), kept constant. Therefore,

$$h_{ie} = \frac{\Delta V_{BE}}{\Delta I_B}, \Delta V_{CE} \text{ constant}$$

It is the slope of CB input characteristics I_B versus V_{BE} .

The typical value of h_{ie} ranges from 500Ω to 2000Ω .

ii) Output Admittance (h_{oe}):

It is defined as the ratio of change in the (output) collector current to the corresponding change in the (output) collector voltage. With the (input) base current I_B kept constant. Therefore,

$$h_{oe} = \frac{\Delta I_C}{\Delta V_{CE}}, I_B \text{ constant}$$

It is the slope of CE output characteristics I_C versus VCE.

The typical value of this parameter is of the order of 0.1 to $10\mu\text{mhos}$.

iii) Forward Current Gain (h_{fe}):

It is defined as a ratio of the change in the (output) collector current to the corresponding change in the (input) base current keeping the (output) collector voltage VCE constant. Hence,

$$h_{fe} = \frac{\Delta I_C}{\Delta I_B}, V_{CE} \text{ constant}$$

It is the slope of I_C versus I_B curve.

It's typical value varies from 20 to 200.

iv) Reverse Voltage Gain (h_{re}):

It is defined as a ratio of the change in the (input) base voltage and the corresponding change in (output) collector voltage with constant (input) base current, I_B . Hence,

$$h_{re} = \frac{\Delta V_{BE}}{\Delta V_{CE}}, I_E \text{ constant.}$$

It is the slope of V_{BE} versus VCE curve.

It's typical value is of the order of 10^{-5} to 10^{-4}

Characteristics of common collector circuit:

The circuit diagram for determining the static characteristics of an N-P-N transistor in the common collector configuration is shown in fig. below.

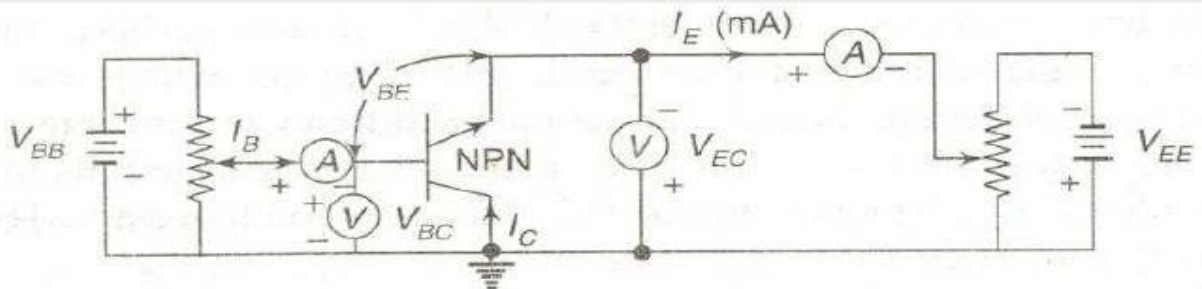

Fig. Circuit to determine CC static characteristics.

Input Characteristics:

To determine the input characteristic, V_{EC} is kept at a suitable fixed value. The base collector voltage V_{BC} is increased in equal steps and the corresponding increase in I_B is noted. This is repeated for different fixed values of V_{EC} . Plots of V_{BC} versus I_B for different values of V_{EC} shown in figure are the input characteristics.

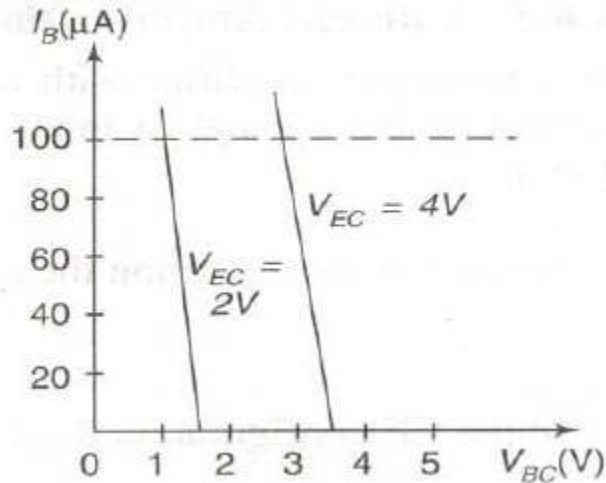

Fig. CC Input Characteristics.

Output Characteristics:

The output characteristics shown in figure below are the same as those of the common emitter configuration.

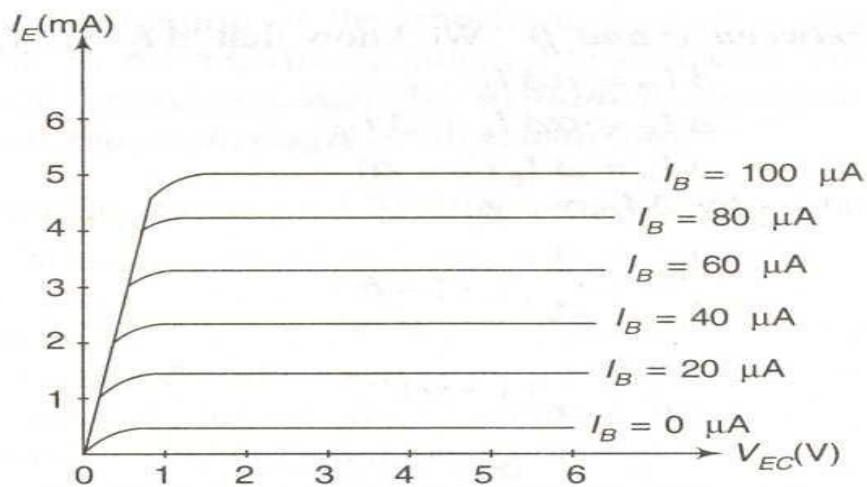

Fig. CC output characteristics.

Problem:

1 A Germanium transistor used in a complementary symmetry amplifier has $I_{CBO}=10\mu\text{A}$ at 27°C and $h_{fe}=50$. (a) find I_C when $I_B=0.25\text{mA}$ and (b) Assuming h_{fe} does not increase with temperature; find the value of new collector current, if the transistor's temperature rises to 50°C .

Solution: Given data: $I_{CBO} = 10\mu\text{A}$ and $h_{fe} (= \beta) = 50$

a) $I_C = \beta I_B + (1 + \beta) I_{CBO}$

$$= 50 \times (0.25 \times 10^{-3}) + (1 + 50) \times (10 \times 10^{-6}) \text{A}$$

= 13.01 mA

b) $I'_{CBO} (\beta=50) = I_{CBO} \times 2(T_2 - T_1)/10$

$$= 10 \times 2(50 - 27)/10$$

$$= 10 \times 22.3 \mu\text{A}$$

$$= 49.2 \mu\text{A}$$

I_C at 50°C is

$$I_C = \beta I_B + (1 + \beta) I'_{CBO}$$

$$= 50 \times (0.25 \times 10^{-3}) + (1 + 50) \times (49.2 \times 10^{-6})$$

$$= 15.01 \text{ mA.}$$