

GOVERNMENT POLYTECHNIC, PANCHKULA

BRANCH: MECHANICAL ENGINEERING

**SUBJECT: REFRIGERATION AND AIR
CONDITIONING (RAC)**

SEMESTER: 5th

CONTENTS

1. FUNDAMENTALS OF REFRIGERATION

- 1.1 Introduction to refrigeration and air conditioning
- 1.2 Meaning of Refrigerating effect
- 1.3 Units of refrigeration
- 1.4 COP (Coefficient of Performance)
- 1.5 Difference between COP and efficiency
- 1.6 Methods of refrigeration

2. VAPOUR COMPRESSION SYSTEM

- 2.1 Introduction
- 2.2 Principle of vapour compression system
- 2.3 Function of vapour compression system
- 2.4 Parts and necessity of vapour compression system
- 2.5 T- ϕ (Temperature-Entropy) and p-H (Pressure-Enthalpy) charts
- 2.6 Dry, wet and superheated compression
- 2.7 Effect of sub cooling, super heating
- 2.8 Actual vapour compression system
- 2.9 Introduction to air refrigeration system
- 2.10 Advantages and disadvantages of air refrigeration over vapour compression system.

3. REFRIGERANTS

- 3.1 Functions of refrigerant
- 3.2 Classification of refrigerants
- 3.3 Properties of R - 717, R – 22, R–134 (a), CO₂, R – 12, R – 502 refrigerants
- 3.4 Properties of ideal refrigerant
- 3.5 Selection of refrigerant

4. VAPOUR ABSORPTION SYSTEM

- 4.1 Introduction
- 4.2 Principle and working of simple vapour absorption system
- 4.3 Principle and working of Domestic Electrolux refrigeration systems.
- 4.4 Solar power refrigeration system
- 4.5 Advantages and disadvantages of solar power refrigeration system over vapour compression system

CHAPTER 1

FUNDAMENTALS OF REFRIGERATION

INTRODUCTION TO REFRIGERATION AND AIRCONDITIONING

Refrigeration: Refrigeration may be defined as the process of removing heat from a substance under controlled conditions. It also includes the process of reducing and maintaining the temperature of a body below the general temperature of its surroundings. In other words, the refrigeration means a continued extraction of heat from a body whose temperature is already below the temperature of its surroundings.

Air Conditioning: Air Conditioning may be defined as a process by which temperature, humidity, flow and purity of air is controlled simultaneously within a space irrespective of the outside atmospheric conditions.

Applications:

- Air-crafts
- Auditoriums
- Automobiles
- Textiles
- Transportation
- Cold Storage
- Buildings
- Dairies
- Refineries
- Hospitals
- Ice Plants
- Laboratories
- Railways etc.

MEANING OF REFRIGERATION EFFECT

The cooling effect produced by a refrigerating system in a given time is known as refrigerating or refrigeration effect. In S.I. units, it is expressed as kJ/s or kJ/min.

UNITS OF REFRIGERATION

The practical unit of refrigeration is expressed in terms of „tone of refrigeration“ (briefly written as TR). A tone of refrigeration is defined as the amount of refrigeration effect produced by the uniform melting of one tone (1000 kg) of ice from and at 0°C in 24 hours. Since the latent heat of ice is 335 KJ/Kg, therefore one ton of refrigeration. In actual practice, one tone of refrigeration is taken as equivalent to 210 kJ/min or 3.5KW.

COP (COEFFICIENT OF PERFORMANCE)

The coefficient of performance (briefly written as C.O.P) is the ratio of heat extracted in the refrigerator to the work done on the refrigerant. It is also known as theoretical coefficient of performance. Mathematically,

$$\text{Theoretical C.O.P} = Q/W$$

Where, Q = Amount of heat extracted in the refrigerator (or the amount of refrigeration produced, or the capacity of a refrigerator), and

W = Amount of work done.

DIFFERENCE BETWEEN C.O.P. AND EFFICIENCY

The value of co-efficient of performance of a refrigerator, unlike the efficiency of heat engine is much higher than unity. The C.O.P. is the reciprocal of the efficiency of a heat engine. Thus the value of C.O.P. will be greater than unity.

Heat Engine

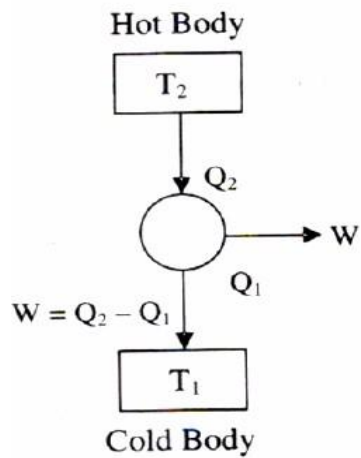

- Produces work by converting energy
- $H = W / Q_2$

Refrigerator

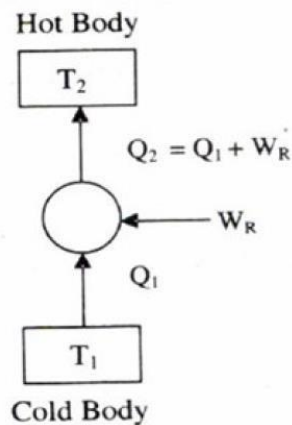

- Consumes work & extracts heat from a cold body & rejects it to a hot body.
- $COP = Q_1 / W$

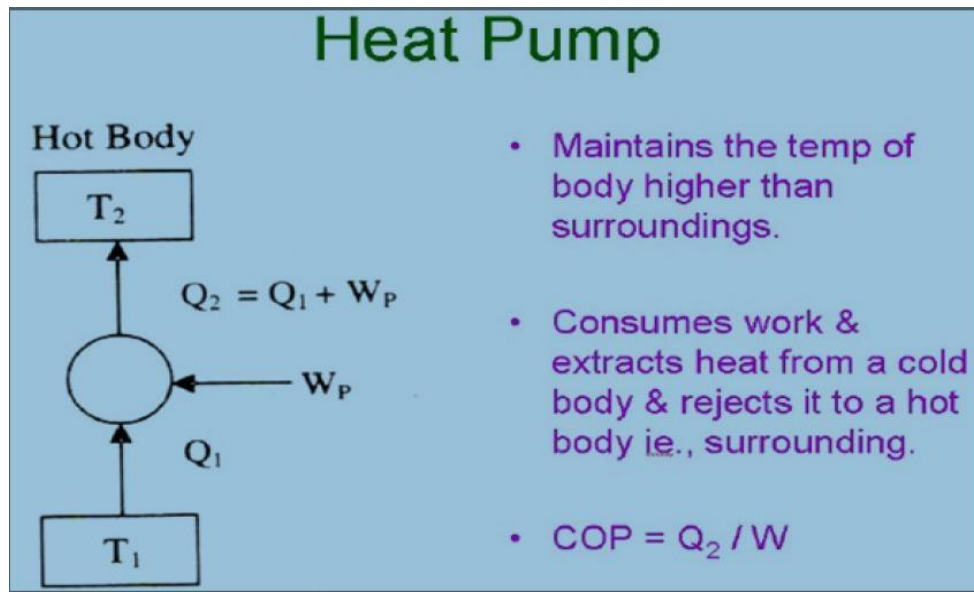

Fig. 1.1 Difference between a Heat Engine, Refrigerator and Heat Pump

METHODS OF REFRIGERATION

1. Ice Refrigeration.
2. Dry ice Refrigeration.
3. Evaporative Refrigeration.
4. Liquid Refrigeration.
5. Gas Throttling Refrigeration.
6. Air expansion Refrigeration.
7. Vapour Compression Refrigeration.
8. Vapour Absorption Refrigeration.

1. Ice Refrigeration:

Refrigeration by ice had been used successfully in the early days and it is still being used as a form of artificial cooling though to a limited degree. It is a direct contact refrigeration system which is useful for small load applications. In this method, the refrigerated space is in direct contact with the ice. In this method the ordinary ice is used for keeping the space at temperature below the surrounding temperature.

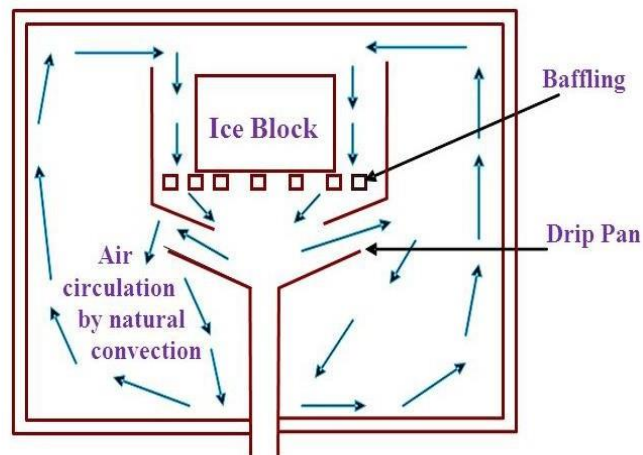

Fig.1.2 Ice Refrigeration

The temperature of ice is considered to be 0 degree Celsius hence it can be used to maintain the temperatures of about 5 to 10 degree Celsius. To use the ice for refrigerating effect a closed and insulated chamber is required. On one side of the chamber ice is kept while on the other side there is a space which is to be cooled where some material to be cooled can be placed. If the temperature below 0 degree Celsius is required, then the mixture of ice and salt is used. This method of cooling is still being used for cooling the cold drinks, keeping the water chilled in thermos, etc.

2. Evaporative Refrigeration:

Evaporative cooling is a type of environment cooling techniques that cools the surrounding air using water evaporation technique. It is used in data center and large IT facilities to provide air cooling / conditioning services. Evaporative cooling is also known as swamp cooling, desert cooling and wet air cooling. Evaporative cooling is one of the simplest and eco-friendly modes of providing environmental cooling within data center facilities.

Evaporative cooling works when water is pumped onto a cooling pad until it's completely wet. A fan near the cooling pad draws air around the cooling pad

and blows it out in the environment / surroundings. The evaporative cooling technique utilizes less energy than other data center cooling techniques, in providing air conditioning services.

3. Dry Ice Refrigeration:

Dry ice is the solid carbon dioxide having the temperature of -78 degree Celsius. Dry ice converts directly from solid state to gaseous; this process is called as sublimation. Dry ice can be pressed into various sizes and shapes as blocks or slabs. Dry ice is usually packed in the frozen food cartons along with the food that has to be kept frozen for long intervals of time. When the dry ice gets converted into vapor state it keeps the food frozen. The process of dry ice refrigeration is now-a-days being used for freezing the food in aircraft transportation.

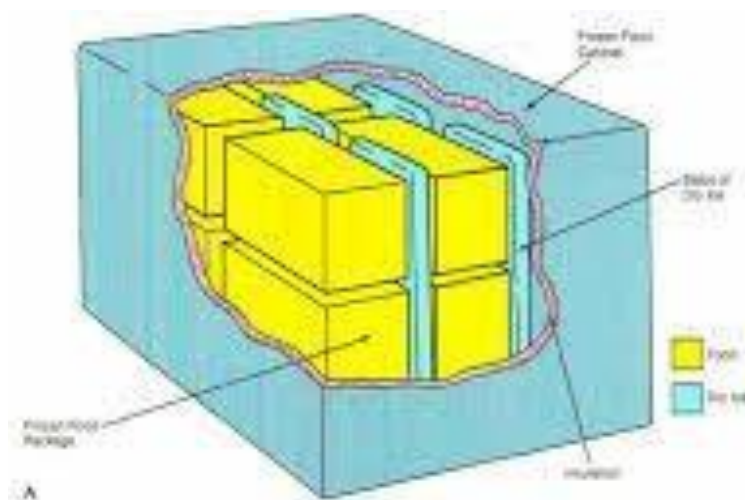

Fig.1.3 Dry Ice Refrigeration

4. Liquid Gas Refrigeration:

This invention relates to a refrigeration system utilizing a liquid gas as a cold reservoir and a vaporizable refrigerant that is circulated through a vaporizer and a condenser, the latter being situated in heat exchange relation with said liquid

gas reservoir to condense the refrigerant. The vapor from the liquid gas is used to drive pump means for circulating the refrigerant through the vaporizer and condenser.

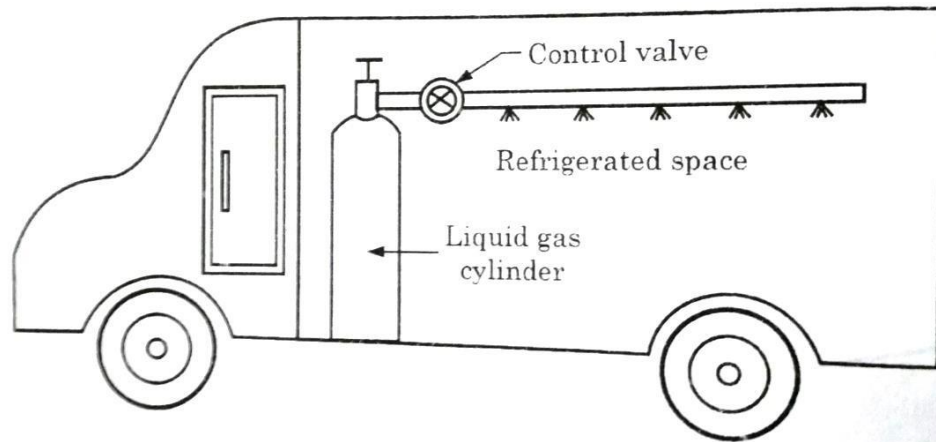

Fig.1.4 Liquid Gas Refrigeration

5. Gas Throttling Refrigeration:

Just as the vapors are used for cooling in the vapor compression cycle and vapor absorption cycle, the gas is used for cooling in gas refrigeration cycle. When the gas is throttled from very high pressure to low pressure in the throttling valve, its temperature reduces suddenly while its enthalpy remains constant. This principle is used in gas refrigeration system.

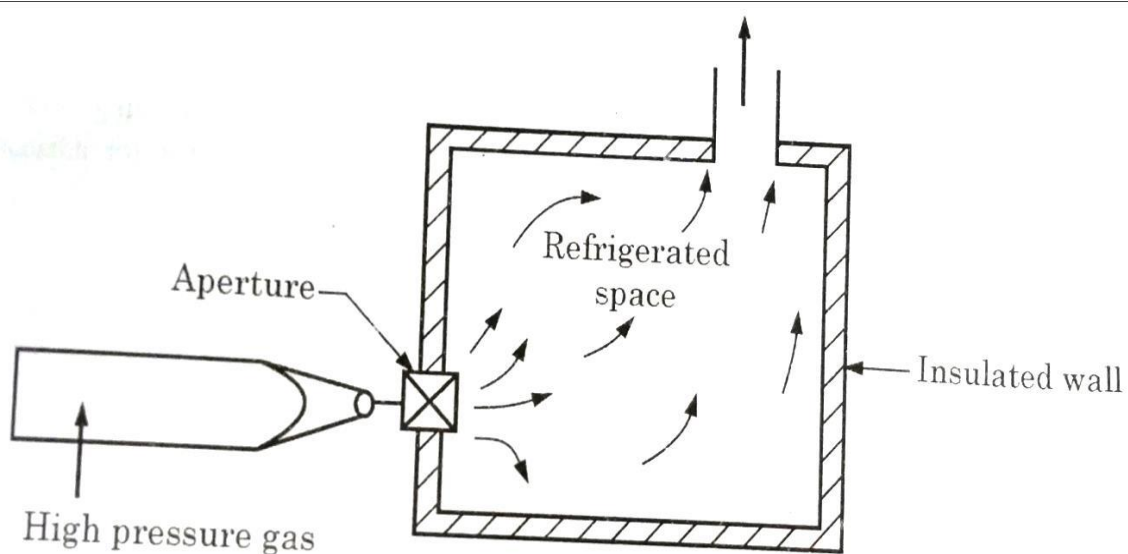

Fig.1.5 Gas Throttling Refrigeration

In this system instead of using Freon or ammonia as the refrigerant, the gas is used as the refrigerant. Throughout the cycle there are no phase changes of the gas, which are observed in the liquid refrigerants. Air is the most commonly used gas, also called as refrigerant in this case, in the gas refrigeration cycles.

6. Air Expansion Refrigeration:

The components of the air refrigeration system are shown in Fig. In this system, air is taken into the compressor from atmosphere and compressed. The hot compressed air is cooled in heat exchanger up to the atmospheric temperature (in ideal conditions). The cooled air is then expanded in an expander. The temperature of the air coming out from the expander is below the atmospheric temperature due to isentropic expansion. The low temperature air coming out from the expander enters into the cabin and absorbs the heat. The cycle is repeated again and again.

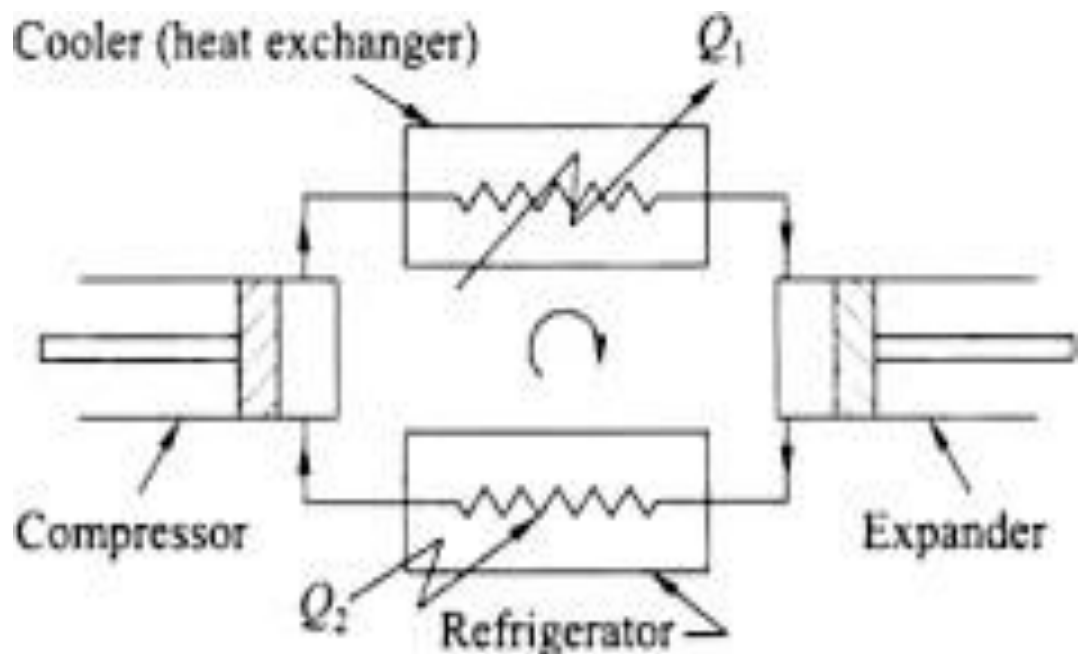

Fig.1.6 Air Expansion Refrigeration

7. Vapour Compression Refrigeration:

A simple vapor compression refrigeration system consists of the following equipment:

- i) Compressor
- ii) Condenser
- iii) Expansion valve
- iv) Evaporator

The vapour at low temperature and pressure enters the compressor where it is compressed isentropically and subsequently its temperature and pressure increase considerably. This vapour after leaving the compressor enters the condenser where it is condensed into high pressure liquid and is collected in a receiver tank. From receiver tank it passes through the expansion valve.

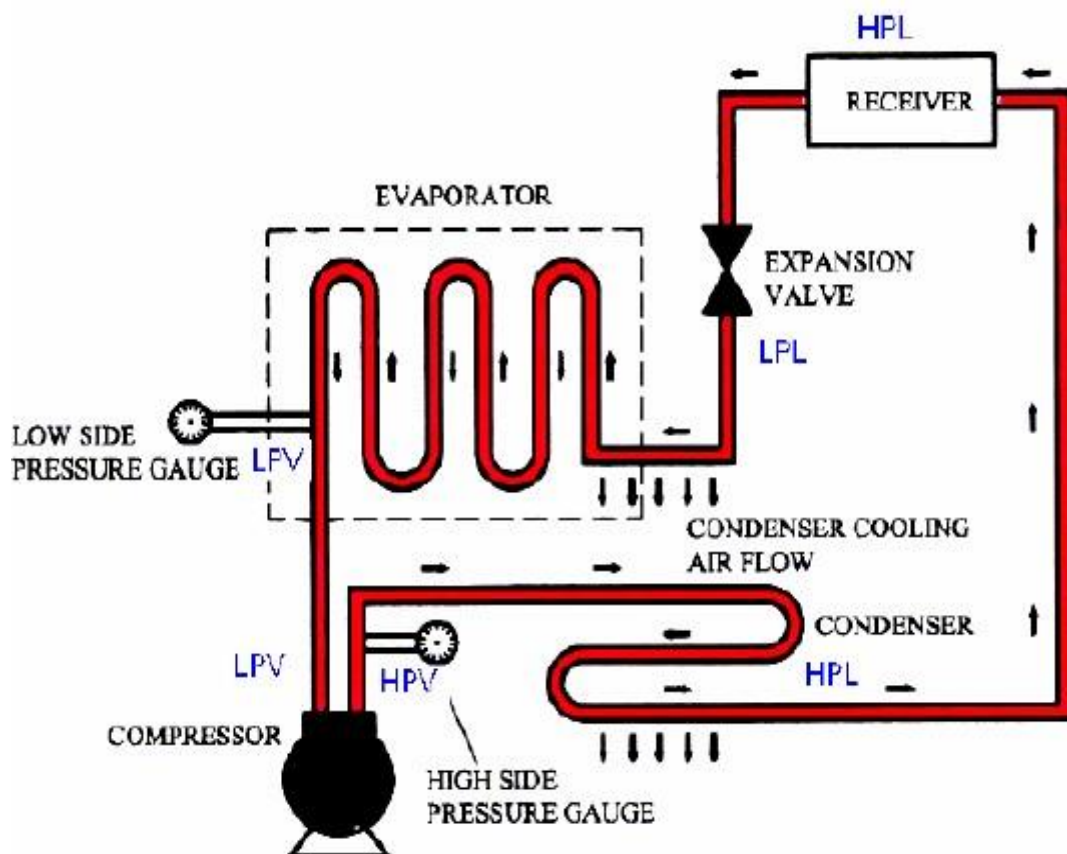

Fig.1.7 Vapour Compression Refrigeration

Here it is throttled down to a lower pressure and has a low temperature. After finding its way through expansion valve it finally passes on to evaporator where it extracts heat from the surroundings or circulating fluid being refrigerated and vaporizes to low pressure vapour.

8. Vapour Absorption Refrigeration:

Some liquids like water have great affinity for absorbing large quantities of certain vapors (NH_3) and reduce the total volume greatly. The absorption refrigeration system differs fundamentally from vapor compression system only in the method of compressing the refrigerant. An absorber, generator and pump in the absorption refrigerating system replace the compressor of a vapor compression system. Figure shows the schematic diagram of a vapor absorption system. Ammonia vapor is produced in the generator at high pressure from the strong solution of NH_3 by an external heating source.

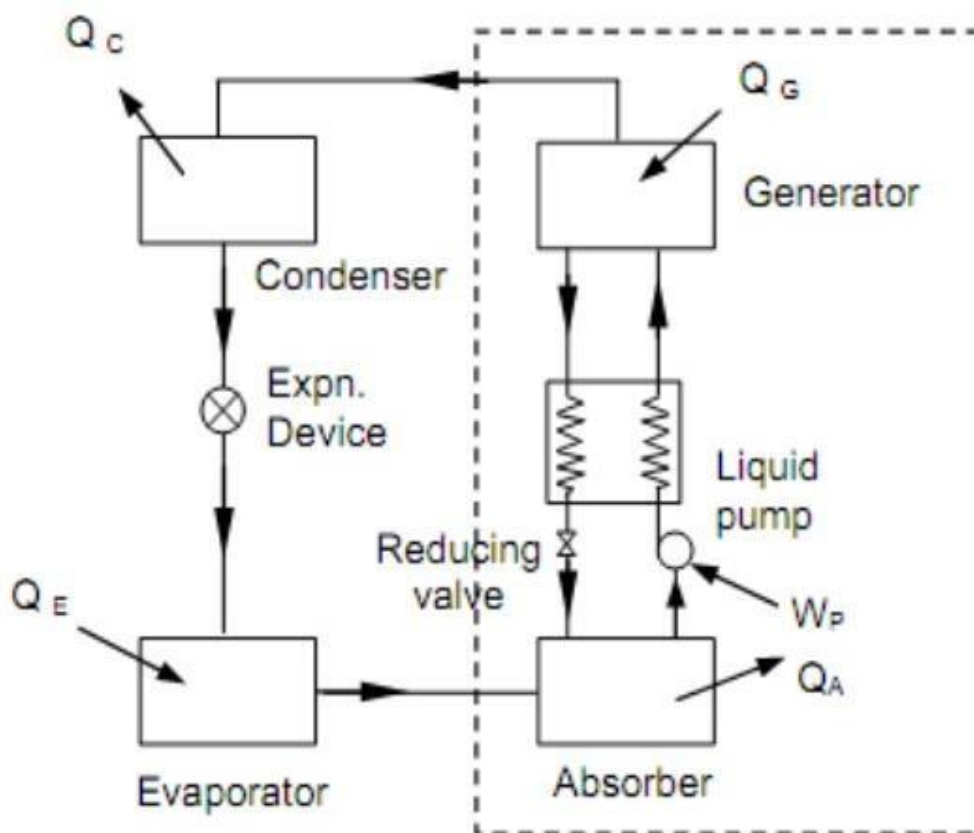

Fig.1.8 Vapour Absorption Refrigeration System

The water vapor carried with ammonia is removed in the rectifier and only the dehydrated ammonia gas enters into the condenser. High pressure NH_3 vapor is condensed in the condenser. The cooled NH_3 solution is passed through a throttle valve and the pressure and temperature of the refrigerant are reduced below the temperature to be maintained in the evaporator. The low temperature refrigerant enters the evaporator and absorbs the required heat from the evaporator and leaves the evaporator as saturated vapor. Slightly superheated, low pressure NH_3 vapor is absorbed by the weak solution of NH_3 which is sprayed in the absorber as shown in fig.

CHAPTER 2

VAPOUR COMPRESSION SYSTEM

INTRODUCTION

A vapour compression system is the modified form of air refrigeration system. In this system low pressure refrigerant from the evaporator is converted into high pressure in the compressor. The refrigerant is circulated in the system without leaving the system. During the process the, refrigerant absorbs the latent heat from the evaporator. This system is used generally for smallest domestic purpose to the big air conditioner plant.

PRINCIPLE OF VAPOUR COMPRESSION SYSTEM Principle of vapour compression refrigeration system is based upon the fact that evaporation cause cooling. During evaporation the liquid takes the latent heat from the substance to be cooled and produces cooling.

FUNCTION OF VAPOUR COMPRESSION SYSTEM

It is a compression process, whose aim is to raise the refrigerant pressure, as it flows from an evaporator. The high-pressure refrigerant flows through a condenser/heat exchanger before attaining the initial low pressure and going back to the evaporator.

A simple vapor compression refrigeration system consists of the following processes:

1. Compression
2. Condensation
3. Expansion
4. Vapourisation

- i. **Compressor:** The refrigerant (for example R-717) enters the compressor at low temperature and low pressure. It is in a gaseous state. Here, compression takes place to raise the temperature and refrigerant pressure. The refrigerant leaves the compressor and enters to the condenser. Since this process requires work, an electric motor may be used.
- ii. **Condenser:** In the condenser, latent heat of vapourisation is removed from the high pressure and high temperature vapours. The vapour are condensed into high pressure liquid and stored into receiver tank.

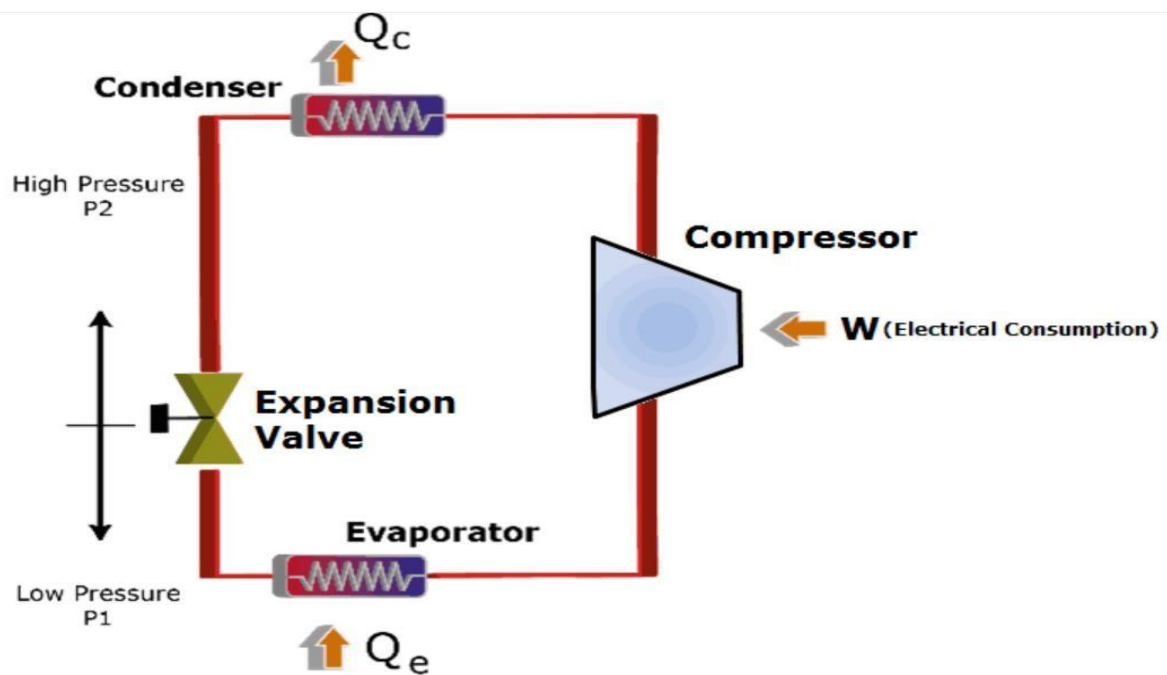

Fig. 2.1 Vapour Compression Refrigeration

- i. **Expansion:** From the receiver tank, the refrigerant enters the throttling valve where it expands and releases pressure. Consequently, the temperature drops at this stage. Because of these changes, the refrigerant leaves the throttle valve as a liquid vapor mixture.
- ii. **Vapourisation:** At this stage of the Vapor Compression Refrigeration Cycle, the refrigerant is at a lower temperature than its surroundings. Therefore, it evaporates and absorbs latent heat of vaporization. Heat extraction from the refrigerant happens at low pressure and temperature. Compressor suction effect helps maintain the low pressure.

PARTS AND NECESSITY OF VAPOUR COMPRESSION SYSTEM

Necessity of Vapour Compression System

The following are the necessities of vapour compression system:

- i)** A compressor is to maintain the two pressure levels i.e. low and high pressure. This is necessary for the function of refrigerant system.
- ii)** A condenser used for reject the heat from the system.
- iii)** An expansion valve is to regulate the flow of the refrigerants.
- iv)** An evaporator to absorb heat forms the system.

In addition to the above, suction line, discharge line, liquid line and receiver tank are also essential parts of the system to maintain the closed circuit.

Parts of Vapour Compression System

The various parts of vapour compression refrigeration system are as shown in Fig. 2.2.

- i) Compressor:** The function of the compressor is to draw refrigerant vapor from the evaporator and to raise Its temperature and pressure to such a point to that it may be easily condensed with normally available condensing media. It also maintains a continuous flow of the refrigerant through the system.
- ii) Discharge line:** It conveys the high pressure and high-temperature refrigerant from the compressor to the condenser.

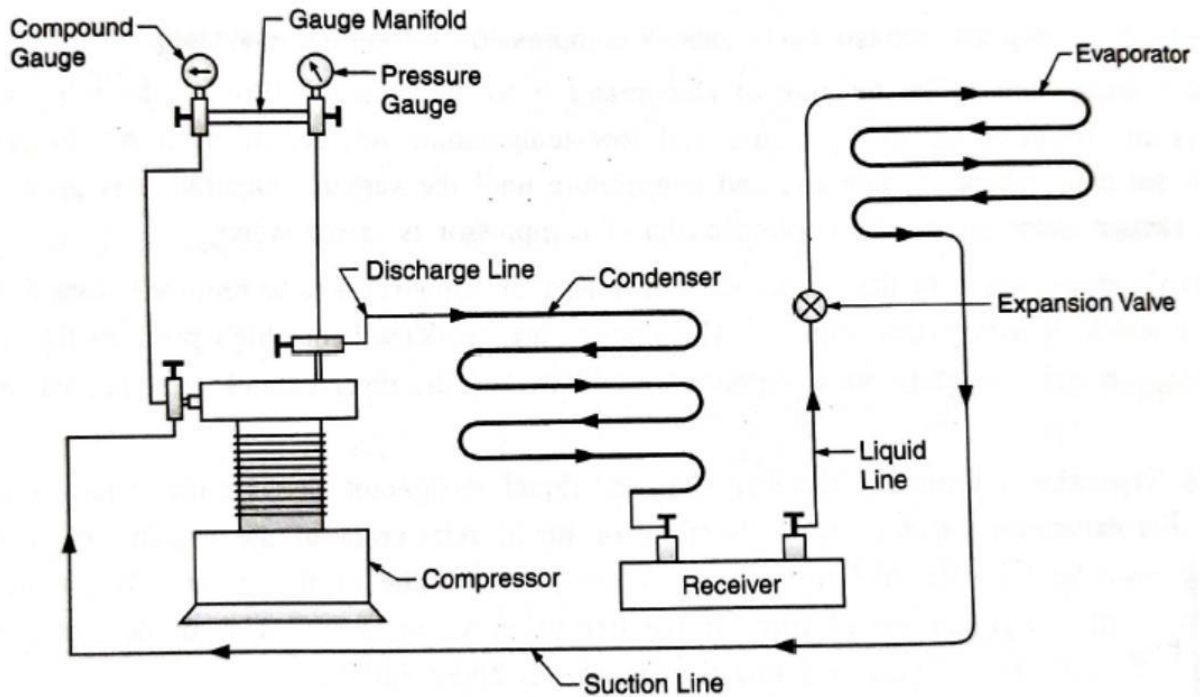

Fig. 2.2 Vapour Compression Refrigeration System

- iii) **Condenser:** The function of the condenser is to provide a heat transfer surface through which heat passes from the refrigerant to the condensing medium which is either water or air.
- iv) **Receiver tank:** It acts as, a reservoir that stores the liquid refrigerant coming from the condenser and supplies it to the evaporator according to the requirement.
- v) **Liquid line:** It carries the liquid refrigerant from the receiver and conveys it to the expansion valve.
- vi) **Expansion valve:** Function of this valve is to Supply a proper amount of refrigerant to the evaporator after reducing its pressure considerably so that the refrigerant may take sufficient amount of heat from the refrigerating space during evaporation.
- vii) **Evaporator:** Its function is to provide a heat transfer surface through which heat can pass from the refrigerated space into the vaporizing refrigerant.

viii) Suction line: It carries the low-pressure vapor from the evaporator to suction inlet of the compressor.

T- ϕ (TEMPERATURE- ENTROPY) AND p-H (PRESSURE- ENTHALPY) CHARTS

T- ϕ (TEMPERATURE- ENTROPY) CHARTS:

The following assumptions are made while drawing T- ϕ chart :

- i) The vapour leaving the evaporator and entering the compressor is dry saturated.
- ii) The compression of the vapour in the compressor is isentropic.
- iii) There is no pressure loss in the system.
- iv) There is no under cooling in the system.

P-H (PRESSURE- ENTHALPY) CHARTS:

The P-h chart showing in fig. 2.3 is the most common chart to study the behavior of refrigerant.

The vertical lines represent pressure and horizontal lines represent enthalpy in the fig. 2.3. The saturation liquid line and the saturated vapour line merges into one another at the critical point. The space to the left of the saturated liquid line is subcooled liquid region. The space between the line and the vapour lines is called wet vapour region while to the right of the saturated vapour line is the super-heated vapour region.

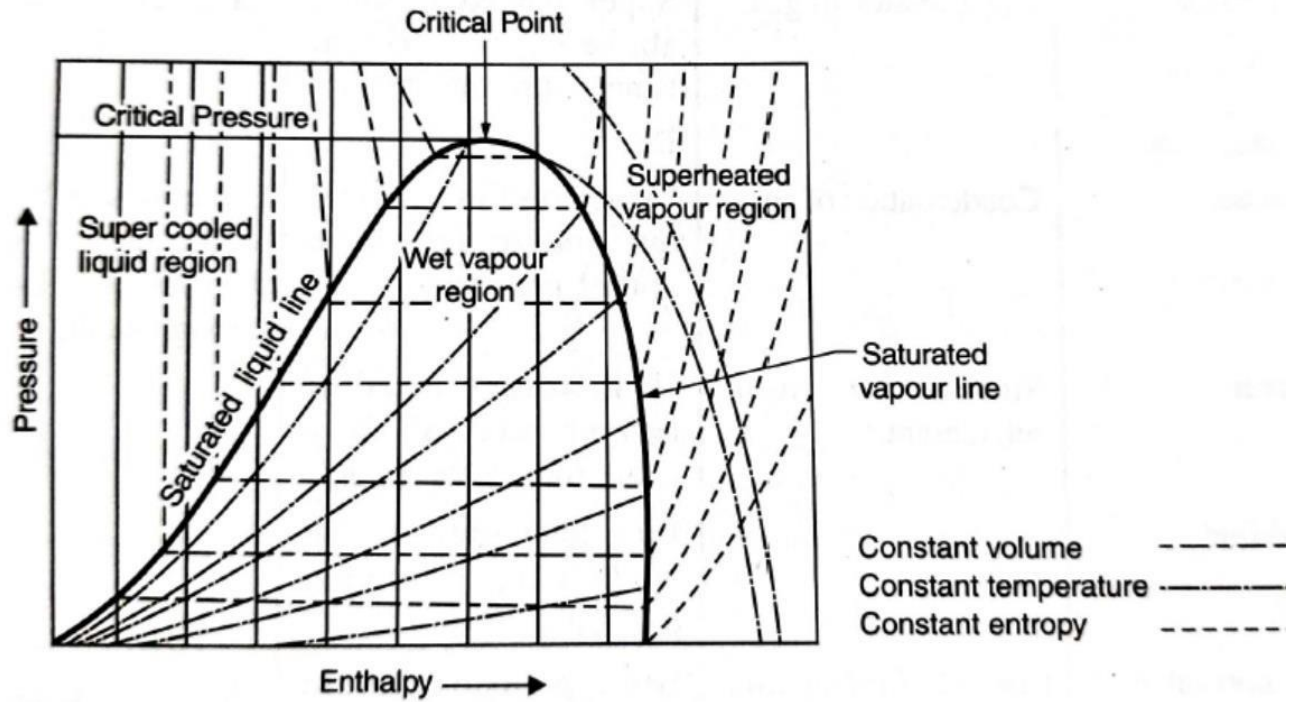

Fig. 2.3 Pressure-Enthalpy (P-h) chart

DRY, WET AND SUPERHEATED COMPRESSION

WHEN THE VAPOUR IS DRY AND SATURATED AT THE END OF COMPRESSION

Fig 2.4(a) and (b) respectively shows a vapour compression cycle on T- ϕ and P-h charts. At point 1, the wet vapour refrigerant having low temperature and pressure T_1 , P_1 and entropy ϕ_1 enters the compressor from the evaporator. To complete one cycle of operations the four processes i.e. Compression, Condensing, expansion and evaporation are shown in figure.

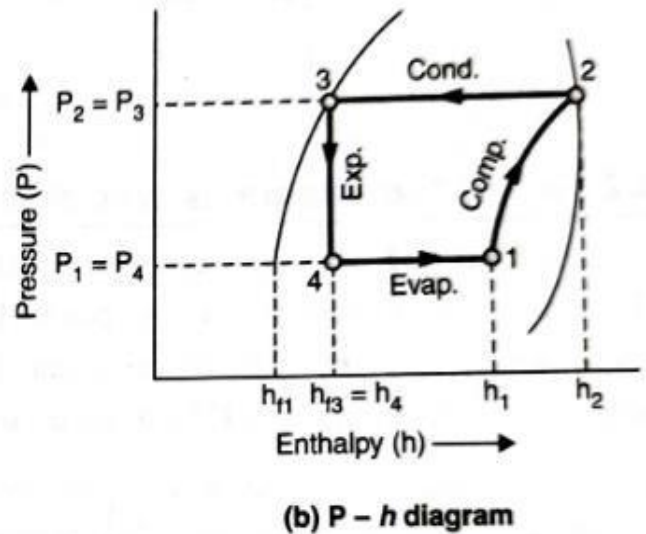
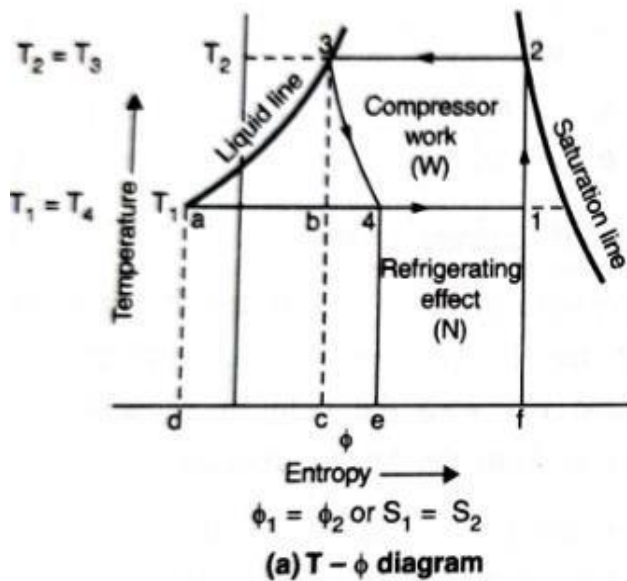

Fig. 2.4 Vapour compression cycle for dry compression

$$\text{COP} = \text{RE}/\text{W} = \text{N}/\text{W}$$

$$\text{COP} = (h_1 - h_4)/(h_2 - h_1)$$

WHEN THE VAPOUR IS WET AT THE END OF COMPRESSION

Fig. 2.5 shows the wet vapour compression cycle on T- ϕ and P-h charts.

In this cycle, the dryness fraction at point 1 and 2 may be calculated

by equating entropies at points 1 and 2 and the enthalpy at point 2 is

found out with the help of dryness fraction. Coefficient of performance

(COP) is:

$$\text{COP} = (h_1 - h_{f3})/(h_2 - h_1)$$

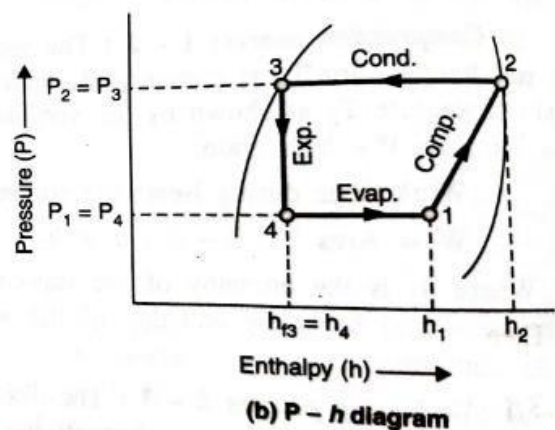
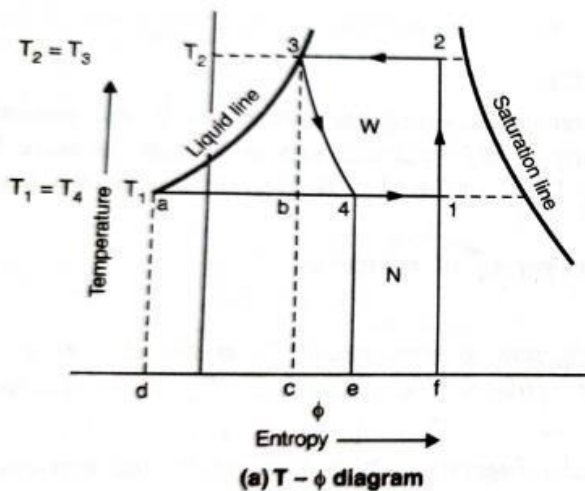

Fig. 2.5 Vapour compression cycle for wet compression

WHEN THE VAPOUR IS SUPERHEATED AT THE END OF COMPRESSION

Fig. 2.6 shows the vapour compression cycle with super-heated vapour on T-φ and P-h charts. The enthalpy at point 2 is calculated with the help of super heat and the degree of superheat is found out by equating entropies at point 1 and 2. In this case, the super heated vapour first condenses to dry saturated vapour at constant pressure as shown by line 2-2'' and then it condenses temperature and pressure shown by line 2'''-3.

$$\text{COP} = (h_1 - h_{f3}) / (h_2 - h_1)$$

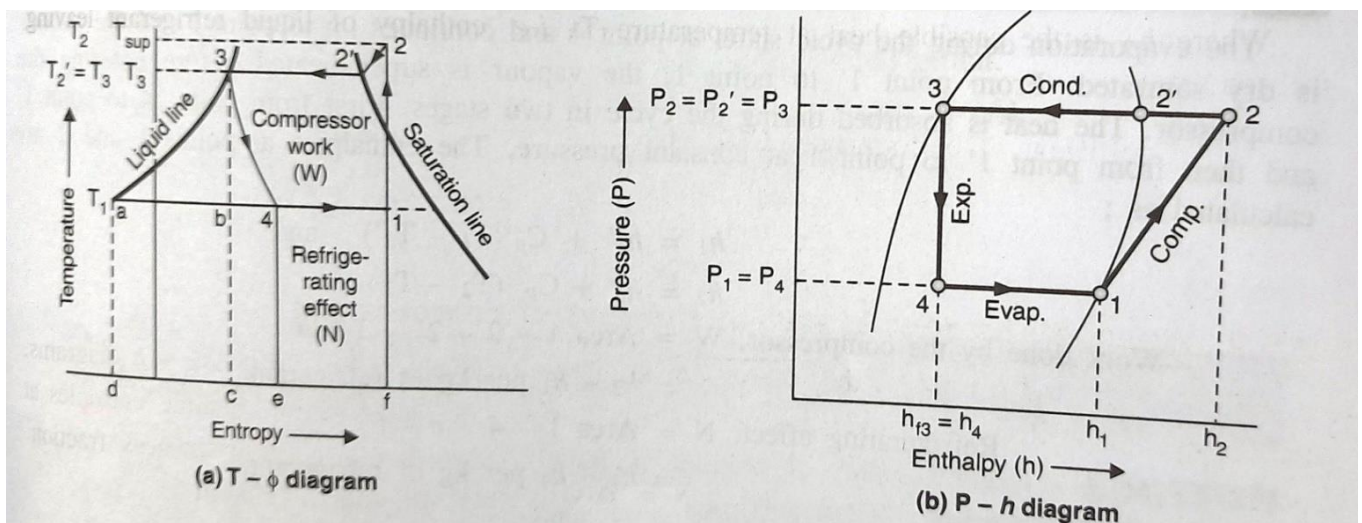

Fig. 2.6 Vapour compression cycle for superheated compression

EFFECT OF SUB COOLING, SUPER HEATING

EFFECT OF SUB COOLING

The refrigerant is said to be sub cooled when the liquid below the condensation temperature corresponding to a given pressure before expansion by throttling.

The process of sub cooling is shown in fig. 2.7 on P-h diagram. It is evident from the diagram that the effect of sub cooling increase the refrigerating effect i.e. under cooling of the liquid refrigerant from 3 to 3'' on the condensing line increases the refrigerating effect from the 4'' to 4 on the evaporator line. Therefore the effect of sub cooling helps to increase the value of cop under the same set of conditions.

- i. The refrigerant after condensed in the condenser at point 3 as shown in the fig.2.7 is passed through a pre cooler where water having

temperature lower than that used in the condenser is circulated to under cool the refrigerant.

- ii. By using the heat exchanger and passing the liquid refrigerant through it where the cold vapours coming from the evaporator flow in the reverse direction before entering the suction of the compressor.

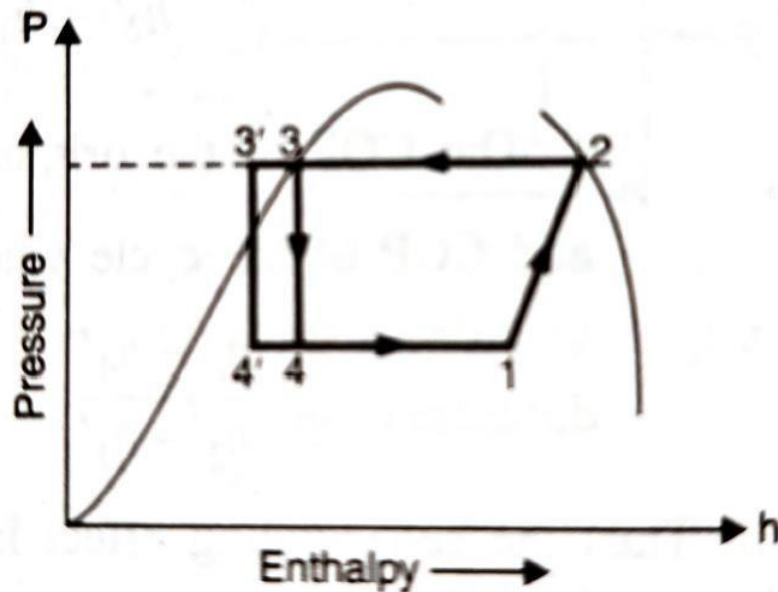

Fig. 2.7 Effect of subcooling of liquid

EFFECT OF SUPERHEATING

Effect of superheating: As shown in the figure a & b the effect of superheating is to increase the refrigerating effect, but this increase in the refrigerating effect is at the cost of increase in amount of work spent to attain upper pressure limit. Since the increase in work is more as compared to increase in refrigerating effect, therefore overall effect of superheating is to give a low value of C.O.P.

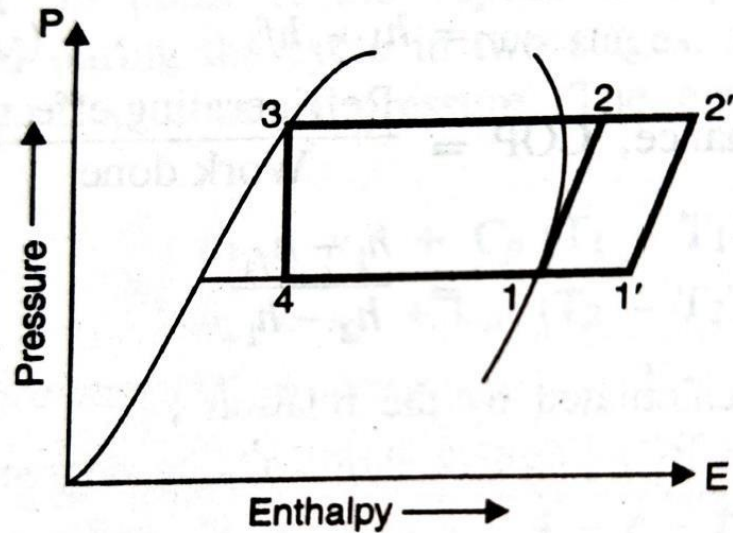

Fig. 2.8 Effect of superheating

ACTUAL VAPOUR COMPRESSION SYSTEM

The actual vapour compression cycle differs from the theoretical vapour compression cycle in many ways, some of which are unavoidable and cause losses. The main deviations between the theoretical cycle and actual cycle are as follows:

1. The vapour refrigerant leaving the evaporator is in superheated state.
2. The compression of refrigeration is neither isentropic nor polytropic.
3. The liquid refrigerant before entering the expansion valve is sub-cooled in the condenser.
4. The pressure drops in the evaporator and condenser.

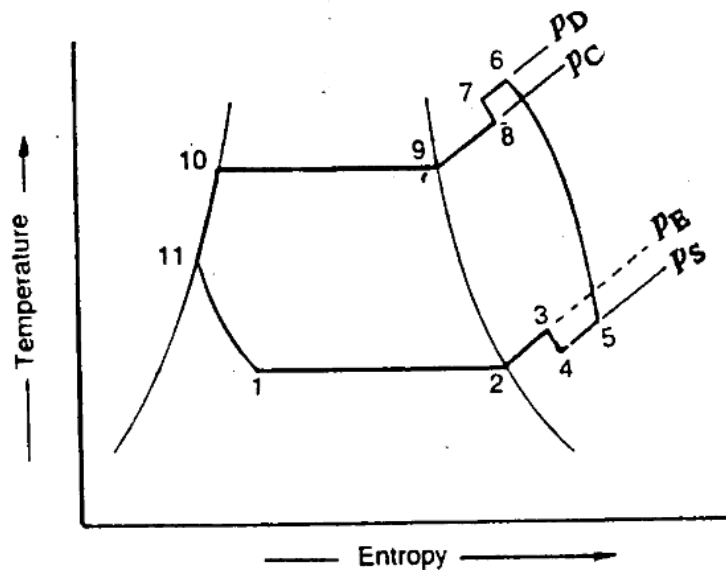

Fig. 2.9 Actual Vapour Compression Cycle

The actual vapour compression cycle on T-s diagram is shown in fig.2.8. The various processes are discussed below

(a) Process 1-2-3: This process shows the flow of refrigerant in the evaporator. The point 1 represents the entry of refrigerant into the evaporator and the point 3 represents the exit of refrigerant from evaporator in a superheated state. The point 3 also represents the entry of refrigerant into the compressor in a superheated condition. The superheating of vapour refrigerant from point 2 to point 3.

(b) Process 3-4-5-6-7-8: When the refrigerant enters the compressor through the suction valve at point 3, the pressure falls to point 4 due to frictional resistance to flow. During suction and prior to compression, the temperature of the cold refrigerant vapour rises to point 5 when it comes in contact with the compressor cylinder walls. The actual compression of the refrigerant is shown by 5-6, which is neither isentropic nor polytropic. This is due to the heat transfer between the cylinder walls and the vapour refrigerant.

Like the heating effect at suction given by 4-5, there is a cooling effect at discharge as given by 6-7. These heating and cooling effects take place at constant pressure. Due to the frictional resistance of flow, there is a pressure

drop i.e., the actual discharge pressure (P_d) is more than the condenser pressure (P_c).

(c) Process 8-9-10-11: This process represents the flow of refrigerant through the condenser. The process 8-9 represents the cooling of superheated vapour refrigerant to the dry saturated state. The process 9-10 shows the removal of latent heat which changes the dry saturated refrigerant into liquid refrigerant. The process 10-11 represents the sub-cooling of liquid refrigerant in the condenser before passing through the expansion valve.

(d) Process 11-1: This process represents the expansion of subcooled liquid refrigerant by throttling from the condenser pressure to the evaporator pressure.

INTRODUCTION TO AIR REFRIGERATION SYSTEM

The components of the air refrigeration system are shown in Fig. In this system, air is taken into the compressor from atmosphere and compressed. The hot compressed air is cooled in heat exchanger up to the atmospheric temperature (in ideal conditions). The cooled air is then expanded in an expander.

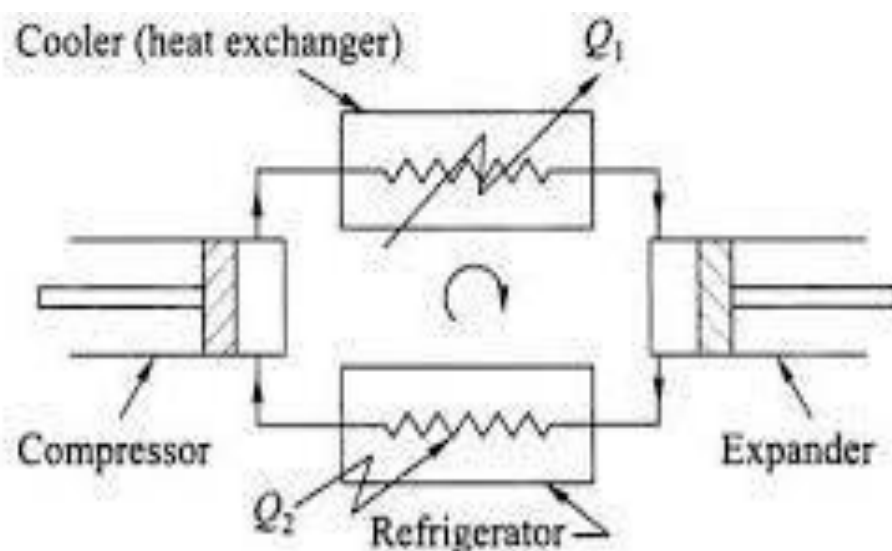

Fig. 2.10 Air Expansion Refrigeration

The temperature of the air coming out from the expander is below the atmospheric temperature due to isentropic expansion. The low temperature air coming out from the expander enters into the cabin and absorbs the heat. The cycle is repeated again and again.

ADVANTAGE AND DISADVANTAGE OF AIR REFRIGERATION OVER VAPOUR COMPRESSION SYSTEM

ADVANTAGES: The main advantage of air refrigeration is that the working substance or air refrigerant is available always in the atmosphere. Further it is free or no cost is involved. The open air cycle system is simple.

Thus we can say that:

1. The refrigerant air is non poisonous and harmless
2. Air is free and easily and abundantly available.
3. System is very simple as it contains no separate mechanical and electrical power to operate.
4. This system is highly useful for aircraft refrigeration due to light weight less space requirement.

DISADVANTAGES: Disadvantages of air refrigeration over vapour compression system are as follow:

1. It has very low coefficient of performance.
2. It has high operating cost.
3. It has low heat carrying capacity.
4. It requires a large volume of air to be handling and require big size compressor and expander.

CHAPTER 3

REFRIGERANTS

FUNCTION OF REFRIGERANT

The refrigerant is heat carrying mediums which during their cycle (i.e. Compression, condensation, expansion and evaporation) in the refrigeration system absorb heat from a low temperature system and discard the heat so absorbed to a higher temperature system. The natural ice and a mixture of ice and salt were the first refrigerants. In 1834, ether, ammonia, sulphur dioxide, methyl chloride and carbon dioxide came into use as refrigerants in compression cycle refrigeration machines. The suitability of refrigerant for a certain application is determined by its physical, thermodynamic, chemical properties and by various practical factors. There is no one refrigerant which can be used for all types of applications i.e. there is no ideal refrigerant.

CLASSIFICATION OF REFRIGERANTS

1. Primary Refrigerants

2. Secondary refrigerants

The refrigerants which directly take parting the refrigeration system are called primary refrigerants whereas the refrigerants which are first cooled by primary refrigerants and then used for cooling purposes are known as secondary refrigerants.

The primary refrigerants are further classified into the following four groups:

1. Halo carbon refrigerants

2. Azeotrope refrigerants

3. Inorganic refrigerants

4. Hydro-carbon refrigerants

1. Halo-carbon Refrigerants

The American society of Heating, Refrigeration and Air-conditioning Engineers (ASHRAE) identifies 42 halo-carbon compounds as refrigerants, but only a few of them are commonly used. The following table gives some of the commonly used halo-carbon refrigerants:

Table 1: Halo carbon refrigerants

<i>Refrigerant number</i>	<i>Chemical name</i>	<i>Chemical formula</i>
R-11	Trichloromonofluoromethane	CCl_3F
R-12	Dichlorodifluoromethane	CCl_2F_2
R-13	Monochlorotrifluoromethane	CClF_3
R-14	Carbontetrafluoride	CF_4
R-21	Dichloromonofluoromethane	CHCl_2F
R-22	Monochlorodifluoromethane	CHClF_2
R-30	Methylene chloride	CH_2Cl_2
R-40	Methyl chloride	CH_3Cl
R-100	Ethyl chloride	$\text{C}_2\text{H}_5\text{Cl}$
R-113	Trichlorotrifluoroethane	$\text{CCl}_2\text{FCClF}_2$
R-114	Dichlorotetrafluoroethane	$\text{CClF}_2\text{CClF}_2$
R-115	Monochloropentafluoroethane	CClF_2CF_2

2. Azeotropes:

An azeotrope is a suitable mixture of two Refrigerants which cannot be separated into its compounds by distillation. An azeotrope evaporates and condenses as a single substance that the vapours have the same composition as the liquid.

Table 2: Azeotrop

<i>Refrigerant number</i>	<i>Azeotropic mixing refrigerants</i>	<i>Chemical formula</i>
R-500	73.8% R-12 and 26.2% R-152	$\text{CCl}_2\text{F}_2/\text{CH}_3\text{CHF}_2$
R-502	48.8% R-22 and 51.2% R-115	$\text{CHClF}_2/\text{CClF}_2\text{CF}_3$
R-503	40.1% R-23 and 59.9% R-13	$\text{CHF}_3/\text{CClF}_3$
R-504	48.2% R-32 and 51.8% R-115	$\text{CH}_2\text{F}_2/\text{CClF}_2\text{CF}_2$

3. Hydrocarbons:

These are organic compounds. These have a high tendency to burn or to form combustible mixtures with a wide range of concentration of air though these possess satisfactory thermodynamic properties. These are now not used much in common applications but are found to be suitable as refrigerants in petroleum and petro-chemical industries.

Table 3: Hydrocarbons

<i>Refrigerant number</i>	<i>Chemical name</i>	<i>Chemical formula</i>
R-170	Ethane	C_2H_6
R-290	Propane	C_3H_8
R-600	Butane	C_4H_{10}

4. Unsaturated Organic Compounds:

These are hydrocarbons with mainly ethylene or propylene base.

Table 4: Unsaturated Organic Compounds

<i>R-1120</i>	Trichloroethylene	$C_2H_2Cl_3$
<i>R-1130</i>	Dichloroethylene	$C_2H_2Cl_2$
<i>R-1150</i>	Ethylene	C_2H_4
<i>R-1270</i>	Propylene	C_3H_6

5. Inorganic Compounds:

The inorganic compounds under this group were universally employed before the introduction of hydrocarbons compounds. Many of them are being still used in various refrigeration applications.

Table 5: Inorganic Compound

<i>Refrigerant number</i>	<i>Chemical name</i>	<i>Chemical formula</i>
<i>R-717</i>	Ammonia	NH_3
<i>R-729</i>	Air	—
<i>R-744</i>	Carbon dioxide	CO_2
<i>R-764</i>	Sulphur dioxide	SO_2
<i>R-118</i>	Water	H_2O

PROPERTIES OF REFRIGERANTS

1. R-717 (Ammonia): Ammonia is amongst the oldest of all the refrigerants and still used widely in the refrigeration applications. Ammonia refrigerant is commonly known as R717 and its chemical formula is NH_3 . Its molecular weight is 17 and boiling point is -28 degree F (-2.22 degree C).

Different properties of ammonia are given below:

2. One of the biggest advantages of ammonia gas as the refrigerant is that it is safe to the environment and does not cause any depletion of the ozone layer.
3. The discharge temperature of the ammonia refrigerant from the compressor is high.
4. Ammonia is non-corrosive in nature, however, in presence of moisture it tends to become corrosive to copper, brass and other non-ferrous materials.
5. Ammonia refrigerant is non-miscible with oil so it does not mix with the oil in the crankcase of the compressor.
6. The leak testing of ammonia from the refrigeration system can be done either by using sulfur sticks or soap solution. When ammonia reacts with sulfur, a dense smoke is formed.

2. R-22 (Freon): R22 refrigerant is one of the most commonly used refrigerants in the air conditioning systems. R22 is the short name for the halocarbon compound CHClF_2 (Dichlorodifluoromethane), which is used as the refrigerant. R stands for the refrigerant. In the number “22” second “2” denotes the number of the fluorine atoms in the compound.

- R-22 was used extensively in domestic, commercial as well as industrial low-temperature systems to evaporator temperatures as low as -87°C .
- Both atmospheric pressure and discharge temperature are higher.
- Evaporator temperatures are between -28 to -40°C .
- The ability of R22 to absorb moisture is comparatively greater, therefore, less trouble due to ice formation.
- Fluorocarbon based refrigerants are safe.
- Use a halide torch for leak detection.
- R22 was completely phased out due to its high ozone depleting potential.

3. R-134(a) (HCF): Coming from the HFC (hydrofluorocarbons) family of refrigerants, R134a is also known as tetrafluoroethane (CH_2FCF_3) consisting of two carbon atoms, 2 hydrogen atoms and 4 fluorine atoms. The properties of R134a refrigerant gas are discussed below:

- R134a is no-toxic, non-flammable and non-corrosive.
- R134a has a boiling point of -15.34 degree Fahrenheit or -26.3 degree Celsius that makes it exist in gas form when exposed to environment. This is a desired property as the boiling point of a refrigerant should be below the target temperature.
- R134a has a high heat of vaporization.
- Its solubility in water is 0.11% by weight at 77degree Fahrenheit or 25 degree Celsius.
- R134a has zero Ozone layer depleting properties and hence became popular as an ideal replacement for dichlorodifluoromethane (R-12), which was known to have an adverse impact on the Ozone layer.
- This refrigerant has a Global Warming Potential (GWP) of 1300. GWP is a relative measure of the amount of heat trapped in the atmosphere by a greenhouse gas.

4. CO₂ (R-744): R-744 has been used in refrigeration for many years. Carbon dioxide offers a long-term solution suitable for many applications in refrigeration and heating, from domestic applications utilizing heat pumps to provide hot water and heating to commercial applications. R-744 has 10 noteworthy characteristics:

- Non-toxic
- Non-flammable
- Low triple point
- Low critical point
- High pressure

- High refrigeration volumetric capacity
- High heat transfer characteristics
- Inexpensive
- Readily available

5. R-12 (CFC): Prior to the environmental issues of ozone layer depletion and global warming, it was the most widely used refrigerant. R-12 was used primarily in small capacity refrigeration and cold storage applications. It is:

- Non-toxic
- Non-flammable
- NBP = -29.8 Deg.C
- Hfg at NBP=165.8 kJ/kg
- Tcr =112.04 Deg. C
- Cp/Cv = 1.126
- ODP = 1.0
- GWP = 7300

6. R-502 (CHCLF₂): It is one of the newer refrigerant. It has replaced R22 because of difficulties of high discharge temperature and poor oil return experienced with R22.The boiling point of R 502 is -46°C. Its various properties are:

- It is non toxic in nature.
- It is non flammable and non irritating.
- It is stable and non corrosive.
- It is suitable for obtaining medium and low temperature range.
- The leak may be detected by soap solution, halide torch detector.

PROPERTIES OF IDEAL REFRIGERANT

We have discussed above that there is no ideal refrigerant. A refrigerant is said to be ideal if it has all of the following properties:

- Low Boiling point
- High critical temperature
- High latent heat of vaporization
- Low specific heat of liquid
- Low specific volume of vapour
- Non-corrosive to metal
- Non-flammable and non-explosive
- Non-toxic
- Low cost
- Easy to liquefy at moderate pressure and temperature
- Easy of locating leaks by odour or suitable indicator, and
- Mixes well with oil.

SELECTION OF REFRIGERANT

While selecting a refrigerant for a particular application, the thermodynamic, physical, chemical and safe working properties etc. of the refrigerant should be properly weighed. The following points are of primary consideration:

1. Working Temperature and pressure range.
2. Toxicity, flammability and corrosiveness.
3. Space Limitations.
4. Oil Miscibility.
5. Temperature required in the evaporator, condenser and that of the cooling medium available.

CHAPTER 4

VAPOUR ABSORPTION SYSTEM

INTRODUCTION

The vapour absorption refrigeration cycle is one of the oldest known cycle of refrigeration. In olden times this refrigeration cycle was used for small units up to 20 ton capacities only.

The absorption system makes use of the heat energy to operate the system rather than the mechanical energy as used in mechanical refrigeration system. This reduces the number of moving parts in the system to the minimum. The only moving parts used by smaller units are the controls and the valves whereas larger units use fans and circulating pumps also. Moving parts are being least, these units are quiet in operation.

PRINCIPLE AND WORKING OF SIMPLE VAPOUR ABSORPTION SYSTEM

The operating principle in this system is simply to absorb the vapour refrigerant after it leaves the evaporator in a solution in the absorber at relatively at low temperature and pressure, to pump mechanically the solution thus formed into the generator at a high pressure and to distill from the solution by the applications of the heat in the generator the refrigerant received in the generator and pass into the condenser. After this the weak solution returns to the absorber to repeat the cycle.

Some liquids like water have great affinity for absorbing large quantities of certain vapors (NH_3) and reduce the total volume greatly. The absorption refrigeration system differs fundamentally from vapor compression system only in the method of compressing the refrigerant.

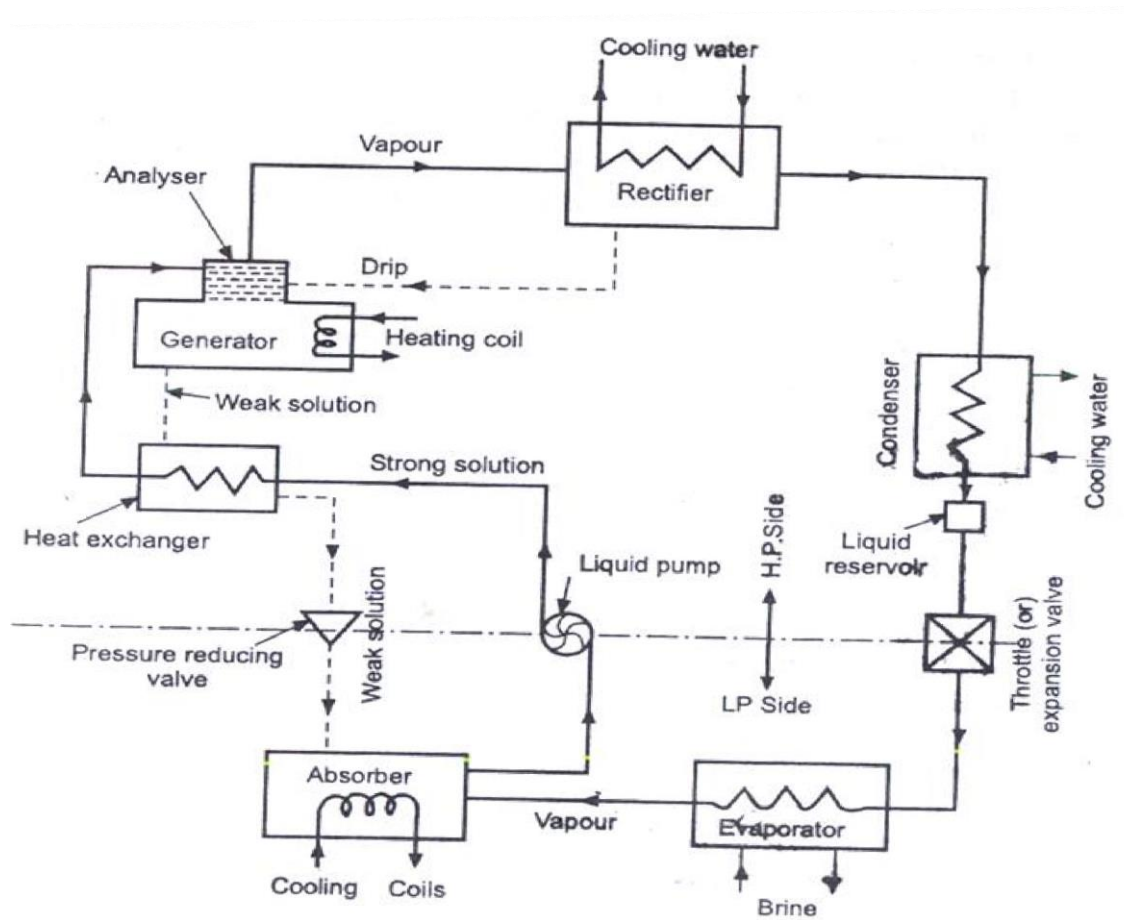

Fig. 4.1 Vapour Absorption System

An absorber, generator and pump in the absorption refrigerating system replace the compressor of a vapor compression system. Figure shows the schematic diagram of a vapour absorption system. Ammonia vapor is produced in the generator at high pressure from the strong solution of NH_3 by an external heating source. The water vapor carried with ammonia is removed in the rectifier and only the dehydrated ammonia gas enters into the condenser. High pressure NH_3 vapor is condensed in the condenser. The cooled NH_3 solution is passed through a throttle valve and the pressure and temperature of the refrigerant are reduced below the temperature to be maintained in the evaporator. The low temperature refrigerant enters the evaporator and absorbs the required heat from the evaporator and leaves the evaporator as saturated

vapor. Slightly superheated, low pressure NH_3 vapor is absorbed by the weak solution of NH_3 which is sprayed in the absorber as shown.

PRINCIPLE AND WORKING OF DOMESTIC ELECTROLUX REFRIGERATION SYSTEM

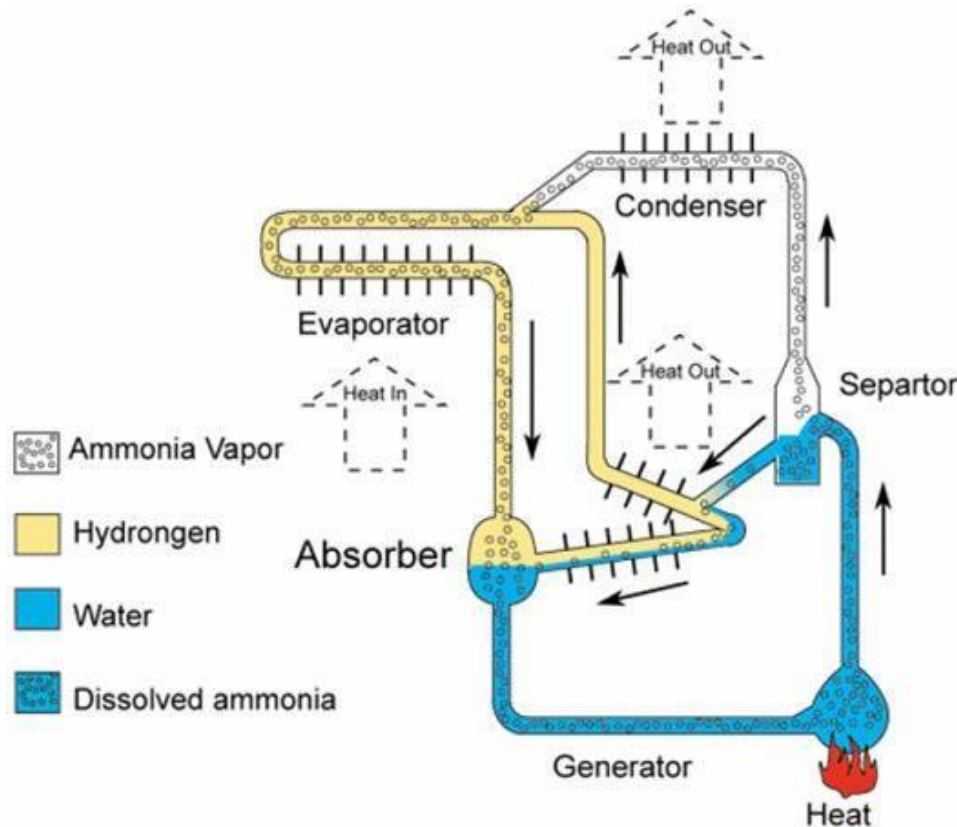

Fig. 4.2 Domestic Electrolux Refrigeration System

The main purpose of domestic electrolux refrigerator is eliminate the pump so that in the absence of moving parts, the machine becomes noise less. This type of refrigerators is also called three fluid absorption system. The three fluid used in this system are ammonia, hydrogen and water. The ammonia is used as refrigerant because it passes most of the desirable properties, The hydrogen begin the lightest gas is used to increase the rate of evaporation of the liquid ammonia passing through the evaporator. The hydrogen is also non corrosive and insoluble in water. The water is used as a solvent because it has the ability to absorb ammonia readily.

SOLAR POWER REFRIGERATION SYSTEM

In this system, low grade energy as heat from solar panel is used as input for chilling purpose.

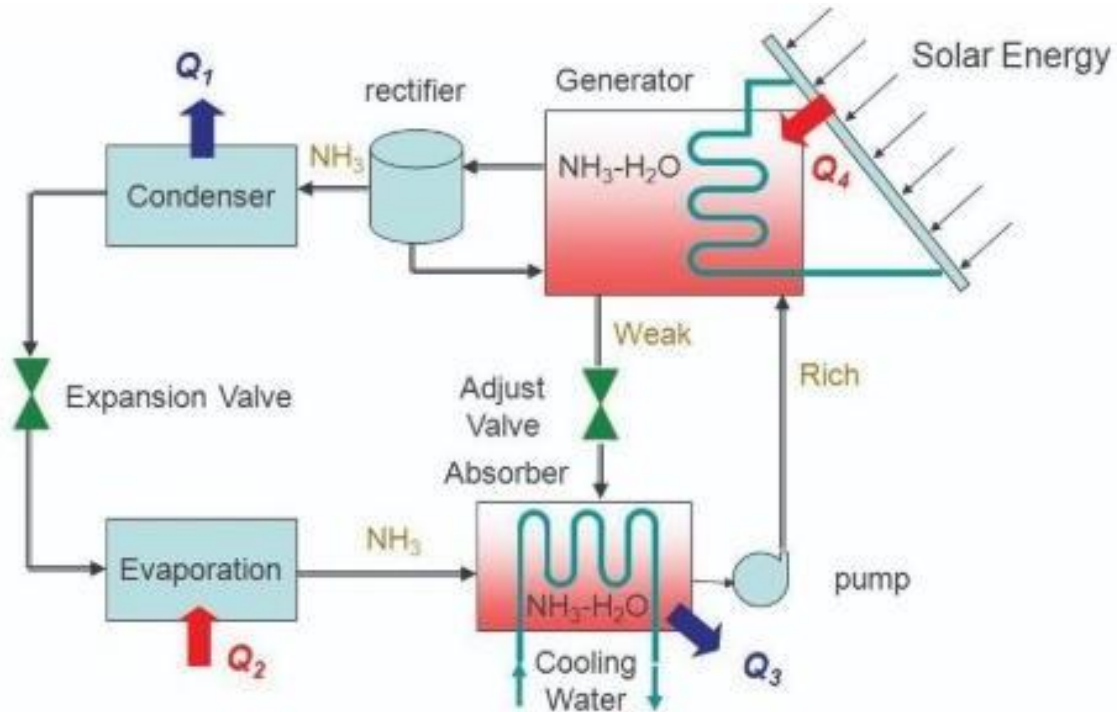

Fig. 4.3 Solar Power Refrigeration System

Figure shows the schematic diagram of a solar absorption refrigeration system. This system is different from a conventional vapour compression refrigeration system. Basic components of such refrigeration system are absorber, generator, solar panel, condenser, expansion valve, evaporator, DC battery and fan. The compressor in the vapour compression system is replaced by a generator, absorber and pump. Refrigerant (NH_3) in the evaporator absorbs the heat from the refrigerated space and gets evaporated. It is then passed to absorber where it is dissolved with absorbent (H_2O) and pumped to generator. Electrical energy from solar panel is utilized for heating in the generator and the refrigerant enters into condenser. The refrigerant is converted to liquid in the condenser and the pressure of the liquid refrigerant is dropped to the evaporator pressure with the help of an expansion device (ED). The main advantage of absorption system is

compression of liquid instead of vapour which results in less mechanical work requirement as input. But the system is much expensive compared to compression refrigeration system.

ADVANTAGES AND DISADVANTAGES OF SOLAR POWER REFRIGERATION SYSTEM OVER VAPOUR COMPRESSION SYSTEM

ADVANTAGES: The main advantages of solar power refrigeration system over vapour compression system are as follows:

- Solar energy is the main source of energy that is utilized to run solar refrigerator. So, significant amount of electrical power is saved.
- It causes less pollution that would have been added due to the use of power produced by the conventional power plants.
- The solar energy is available in every part of the world and unlike fossil fuels and nuclear power, it is a clean source of energy.
- Additional power from the solar collector can also be used for the other domestic purposes.
- The solar refrigerators can be very useful where there is no continuous supply of electricity or difficult to get conventional fuel.
- The maintenance cost of such system is considerably low.

DISADVANTAGES:

The main disadvantages of solar power refrigeration system over vapour compression system are as follows:

- As solar radiation is not available throughout the day, power production is not uniform. Again it depends on the intensity of the beam radiation.

- To produce sufficient energy from solar system, it needs bigger collector. So, there is a need of bigger space for the collector which is another major problem for using solar refrigeration system.
- Initial investment to develop such set up is also large.
- COP is also less as compare to vapour compression system is design for same capacity.
- Sunlight not available at night time, therefore does not work at night.