

GOVERNMENT POLYTECHNIC, PANCHKULA

BRANCH: MECHANICAL ENGINEERING

SUBJECT: STRENGTH OF MATERIALS

SEMESTER: 3rd

CONTENTS

1. Stresses and Strains

- 1.1 Basic concept of load, stress and strain
- 1.2 Tensile, compressive and shear stresses
- 1.3 Linear strain, Lateral strain, Shear strain, Volumetric strain
- 1.4 Concept of Elasticity, Elastic limit and limit of proportionality
- 1.5 Hook's Law and Elastic Constants
- 1.6 Stress-strain curve for ductile and brittle materials
- 1.7 Nominal stress
- 1.8 Yield point, plastic stage
- 1.9 Ultimate stress and breaking stress
- 1.10 Percentage elongation
- 1.11 Proof stress and working stress
- 1.12 Factor of safety
- 1.13 Poisson's Ratio
- 1.14 Thermal stress and strain
- 1.15 Longitudinal and circumferential stresses in seamless thin walled cylindrical shells
- 1.16 Introduction to Principal stresses

2. Resilience

- 2.1 Strain Energy, Resilience, proof resilience and modulus of resilience
- 2.2 Strain energy due to direct stresses and Shear Stress
- 2.3 Stresses due to gradual, sudden and falling load

3. Moment of Inertia

- 3.1 Concept of moment of inertia and second moment of area
- 3.2 Radius of gyration
- 3.3 Theorem of perpendicular axis and parallel axis (with derivation)

3.4 Second moment of area of common geometrical sections : Rectangle, Triangle, Circle (without derivation)

3.5 Second moment of area for L,T and I section, Section modulus

4. Bending Moment and Shearing Force

4.1 Concept of various types of beams and form of loading

4.2 Concept of end supports-Roller, hinged and fixed

4.3 Concept of bending moment and shearing force

4.4 B.M. and S.F. Diagram for cantilever and simply supported beams with and without overhang subjected to concentrated and U.D.L

5. Bending Stresses

5.1 Concept of Bending stresses

5.2 Theory of simple bending, Derivation of Bending Equation

5.3 Use of the equation

5.4 Concept of moment of resistance

5.5 Bending stress diagram

5.6 Section Modulus for rectangular, circular and symmetrical I section

5.7 Calculation of maximum bending stress in beams of rectangular, circular, and T section

6. Columns

6.1 Concept of column, modes of failure

6.2 Types of columns, modes of failure of columns

6.3 Buckling load, crushing load

6.4 Slenderness ratio

6.5 Effective length

6.6 End restraints

6.7 Factors effecting strength of a column

6.8 Strength of column by Euler Formula without derivation

6.9 Rankine Gourdan formula (without derivation)

7. Torsion

7.1 Concept of torsion, difference between torque and torsion

7.2 Derivation of Torsion Equation, use of torsion equation for circular shaft, (solid and hollow)

7.3 Comparison between solid and hollow shaft with regard to their strength and weight

7.4 Power transmitted by shaft

7.5 Concept of mean and maximum torque

8. Spring

8.1 Closed coil helical springs subjected to axial load and calculation of:

- Stress deformation
- Stiffness and angle of twist and strain energy
- Strain energy and proof resilience.

8.2 Determination of number of plates of laminated spring (semi elliptical type only)

1. STRESSES AND STRAIN

INTRODUCTION

Whenever we apply some external force on a body, two situations may arise:

- (i) Either body gets deformed
- (ii) It resists the force applied on it.

The resistance of the body to the applied force is due to cohesion force acting between the molecules. This resistance offered by the material of the body to the applied force is known as strength of material. The body can oppose the deformation only up to a certain limit known as elastic limit. Within elastic limit, the body regains its original shape and the deformation completely disappears on the removal of external force. Thus, the force of resistance per unit area, offered by the body against deformation is called the stress and deformation per unit length is called strain. The various parts of the machines and structures are designed on the basis of external forces acting on them.

BASIC CONCEPT OF LOAD, STRESS AND STRAIN

Load

Load is defined as external force acting upon a machine part. Loads may be classified in two ways:

Classification According to the Nature of Application: Following two types of load are important from this point of view.

- **Dead Load or Steady Load:** These are the loads which are applied very gradually, i.e. increasing from to their maximum value. These loads do not change their magnitude, direction and point of application. These loads always act vertically. Examples-Load of R.C.C. due to self-weight, load on the bridge girder due to its own weight and weight of the other permanent parts of the bridge structure etc.
- **Live or Fluctuating Loads:** A load is said to be live or fluctuating load, when it changes continuously or suddenly. These can further be classified as-
 - **Variable load:** A load is said to be a variable load when it changes continuously. The magnitude of such loads varies. Examples-Weight of The traffic according a bridge, snow load on roofs etc.

- **Suddenly applied load or Shock load:** A load is said to be a suddenly applied or shock load, when it is suddenly applied or removed.
- **Impact load:** A load is said to be an impact load, when it is applied with some initial velocity. Examples hammer blow etc.

Classification of Loads According to the Effects Production on the Member:

Following types of load are important from this point of view

- **Tensile Load:** The loads which tend to pull the member into direction of its application are called tensile loads. These loads cause extension or elongation of the member.

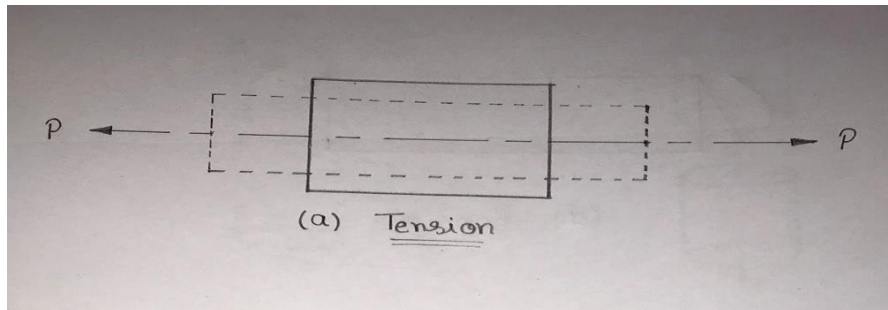

- **Compressive Load:** The load which tends to push together the opposite ends of the member are called compressive loads. These loads cause shortening of the dimension in the direction of their application.

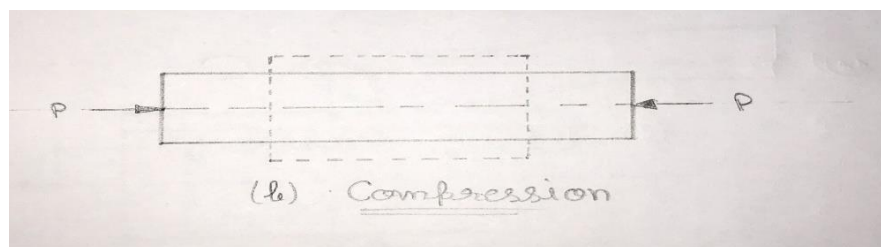

- **Shearing Loads:** The load which tends to cause sliding of one face relative to the other end are called Shearing Loads.

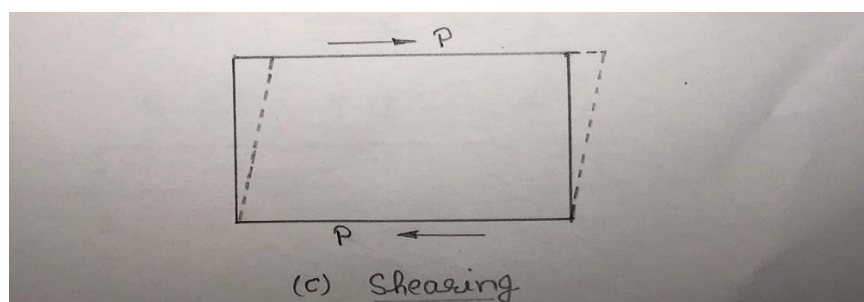

- **Twisting or Torsional Load:** The load produced by two couples applied at opposite ends of the member, tending to cause one end to rotate above its longitudinal axis relative to other end are called twisting or torsional load.

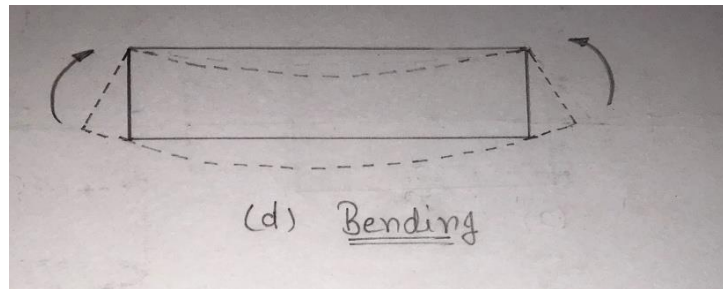

- **Bending Loads:** The loads which tend to cause a certain degree of curvature or bending in the member is called bending loads.

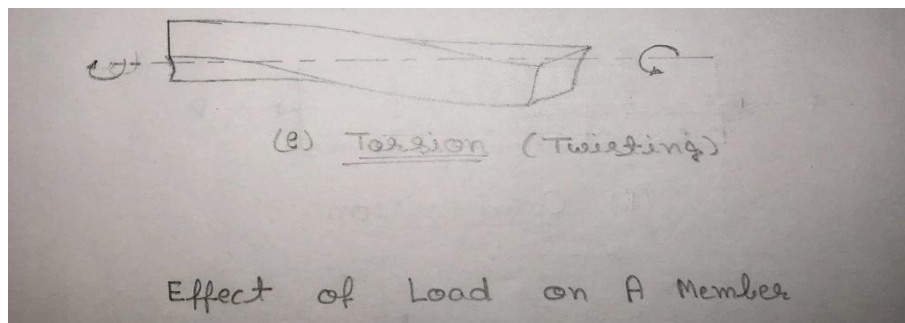

Stress

When a system of external forces or loads acts on a body, a change in its shape and dimension takes place. To oppose the process of deformation, internal resisting forces are set up in the body due to cohesive forces acting between molecules of material. The resisting forces are uniformly distributed over the entire cross-section. The internal resistance per unit area of cross-section is called stress. The difference between the applied load and stress is that the load is applied externally to the body whereas the stress is induced in the body due to application of load.

If a bar, having uniform cross-section area is acted upon by an external force P , due to cohesion between the molecules, the resistance force is developed in the body against the deformation. If we consider any section XX' , divided by the area of cross-section (A) is called intensity of stress or stress.

i.e., **Stress = Force / Area**

In S.I. System unit of stress is N/m^2 or N/mm^2 .

In M.K.S. system, the unit of force is kg and the unit of area is m². Therefore the unit of stress in M.K.S system is kgf/m². If the unit of area is cm² then unit of stress is kg/cm².

Strain

When an external force or a system of forces is applied on a body, the deformation takes place and there will be change in its dimension. The ratio of this change in the dimensions of the body to the original dimensions is known as strain.

i.e. **Strain $e = \frac{\Delta l}{l}$** .

Strain is denoted by e .

It has no unit, because it is the ratio of the same physical quantities. Strain is a measure of the deformation caused due to the original dimensions is known as tensile strain.

TENSILE, COMPRESSIVE AND SHEAR STRESSES

Tensile Stress

The stress produced in the member when it is subjected to two equal; and opposite pulls, tend to elongate it is called tensile stress. Due to tensile load there will be decrease in cross-sectional area and an increase in length of body.

Let an axial tensile force (P_t) is acting on a member of cross-sectional area, A .

Tensile Stress = $\frac{P_t}{A}$ or $F_t = \frac{P_t}{A}$.

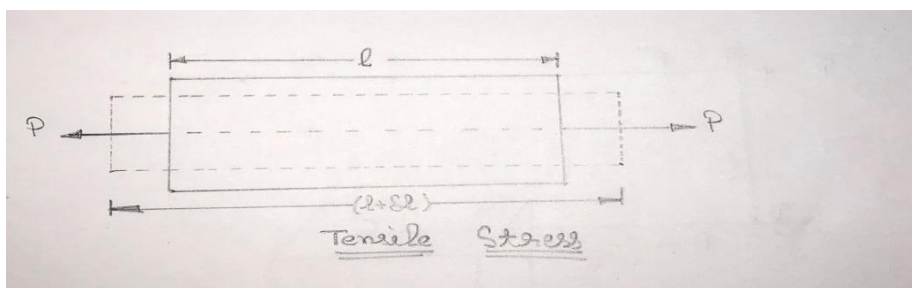

Compressive stress

When a compressive force is applied on a body, the stress induced is called compressive stress. When two equal and opposite forces are applied on a body, it gets compressed. There will be an increase in cross-sectional area and a decrease in the length of body. Let an axial compressive load (P_c) is acting on a member of cross-sectional area, A .

Compressive Stress = $\frac{P_c}{A}$ or $F_c = \frac{P_c}{A}$.

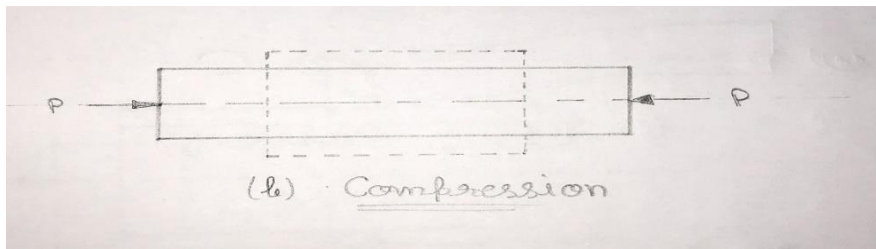

Shear stress: If two equal and opposite forces are applied in such a way that their line of action is tangential to the resisting section the stress induced is known as shear stress.

Shear stress = Error!

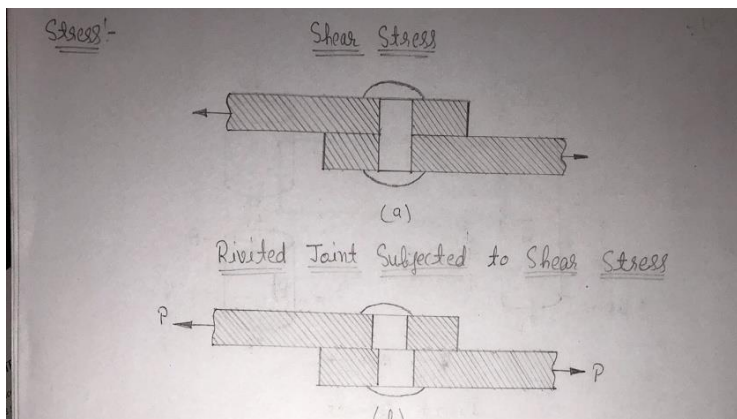

LINEAR STRAIN, LATERAL STRAIN, SHEAR STRAIN, VOLUMETRIC STRAIN

Linear Strain

Linear strain of a deformed body is defined as the ratio of the change in length of the body due to the deformation to its original length in the direction of the force. If l is the original length and dl the change in length occurred due to the deformation, the linear strain e induced is given by $e=dl/l$.

Lateral Strain

Lateral strain of a deformed body is defined as the ratio of the change in length (breadth of a rectangular bar or diameter of a circular bar) of the body due to the deformation to its original length (breadth of a rectangular bar or diameter of a circular bar) in the direction perpendicular to the force.

Volumetric Strain

Volumetric strain of a deformed body is defined as the ratio of the change in volume of the body to the deformation to its original volume. If V is the original volume and dV the change in volume occurred due to the deformation, the volumetric strain e_v induced is given by $e_v = dV/V$

Shear Strain

Shear strain is defined as the strain accompanying a shearing action. It is the angle in radian measure through which the body gets distorted when subjected to an external shearing action. It is denoted by ϕ .

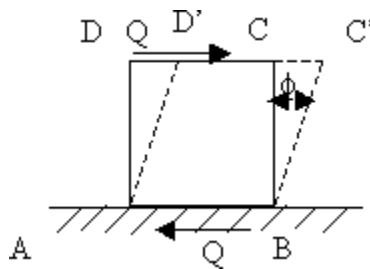

CONCEPT OF ELASTICITY, ELASTIC LIMIT AND LIMIT OF PROPORTIONALITY

Elasticity

Elasticity is the property of material of a body by virtue of which it opposes any change being produced in its shape or size by external force and it tends to regain its original shape and size after the removal of the external force.

Elastic limit

A material is said to be perfectly elastic if the deformation produced by external forces completely disappears on the removal of external forces. For most brittle materials, stresses beyond the elastic limit result in fracture with almost no plastic deformation.

Limit of Proportionality

In the diagram, these are straight line from point O to A, which represent that directly stress is proportional to strain. Beyond point A, the curve slightly deviates from the straight line. Hook's law holds good upto point A and it is known as limit of proportionality. Limit of proportionality may be defined as that stress at which the stress-strain curve begins to deviate from the straight line. The limit of proportionality is the point beyond which Hooke's law is no longer

true when stretching a material. The elastic limit is the point beyond which the material you are stretching becomes permanently stretched so that the material does not return to its original length when the force is removed.

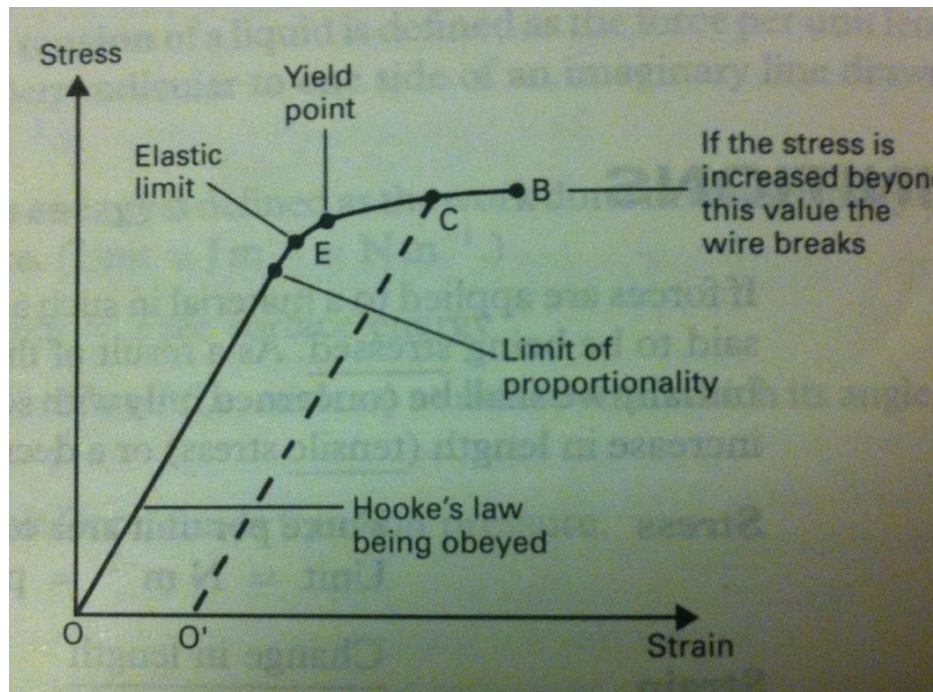

HOOK'S LAW AND ELASTIC CONSTANTS

Hook's Law

Robert Hooke (1635-1703) experimentally established in 1676, that when a material is loaded within elastic limit, the stress is directly proportional to the strain produced by the stress.

i.e. Stress \propto Strain

$$\sigma \propto \epsilon$$

$$\sigma = E \epsilon$$

where E is constant called as Coefficient of elasticity or Elastic constant.

Elastic Constants

Following are the elastic constants

- **Modules of Elasticity or Young's Modules:** it may be defined as the ratio of tensile stress and tensile strain or ratio of compressive stress and compressive strain. It is denoted by E. Young's modules as the same units as that of stress, i.e. N/mm^2

Young's modules, $E = \text{Error!}$

Sr.No.	Material	Modules of Elasticity (E) in GPa
1.	Steel	200 to 220
2.	Wrought iron	190 to to 200
3.	Cast iron	100 to 16
4.	Copper	90 to 110
5.	Brass	80 to 90
6.	Aluminum	60 to 80
7.	Timber	10

- **Modules of Rigidity or Shear Modules:** The ratio of shear stress and shear strain is known as modules of rigidity or shear modulus. This is denoted by G or C.

Modules of rigidity, $G = \text{Error!}$

S.No.	Material	Modulus of rigidity (G) in Gpa
1.	Steel	80 to 100
2.	Wrought	80to 90
3.	iron	40 to 50
4.	Cast iron	30 to 50
5.	Copper	30 to 50
6.	Brass	10

- **Bulk Module:** When a body is subjected to three mutually perpendicular normal stresses of equal intensity, the ratio of normal stress to the corresponding volumetric strain is known as bulk modulus. It is denote by K. The unit of bulk modules is N/mm^2 .

$$K = \text{Error!}$$

STRESS-STRAIN CURVE FOR DUCTILE AND BRITTLE MATERIALS

To plot stress and strain diagram, nominal stresses are calculated by dividing the loads by the original cross-section and the corresponding the stress and strain are plotted on the graph paper by taking strain along X-axis and stresses along Y-axis.

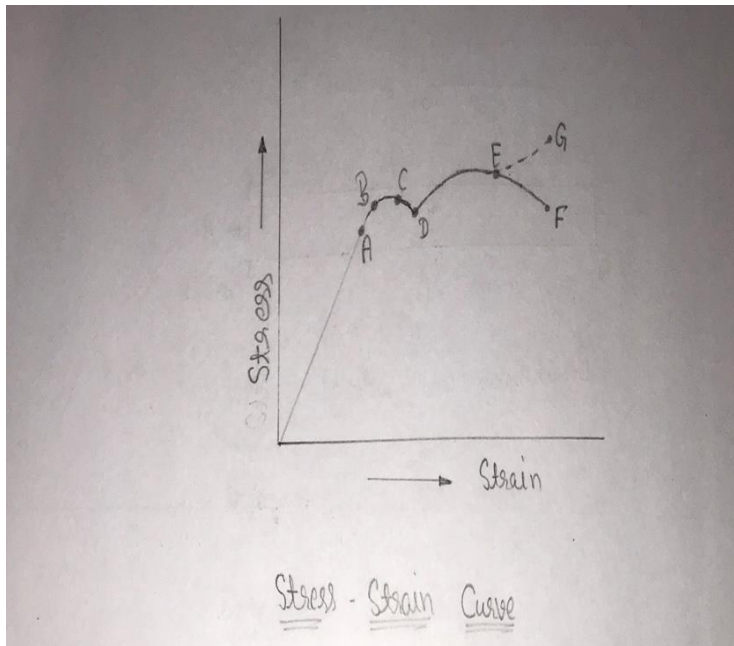

Figure shows that in stress-strain diagram for ductile materials, the curve starts from the origin, showing that there are no initial stresses or strain in the test specimen. The ductile specimen passes through the following stages during loading:-

- Limit of proportionality (Point A)
- Elastic limit (Point B)
- Yield point (Upper yield point C and lower yield point D)
- Maximum or ultimate load point (Point E)
- Breaking point (Point G)

- **Limit of proportionality:** Starting from origin to point A, Hooke's law is obeyed i.e. the stress is proportion to strain. Thus the limit up to which the stress is directly proportional to strain is called limit of proportionality. Therefore OA is straight line. The stress corresponding to point A is called proportionality. Therefore OA is straight line. The stress corresponding to point A is called proportion limit stress (f_p).

Limit of proportionality = Error!

- **Elastic Limit:** The portion of the diagram between AB is not straight line, but up to point B, the material remains elastic, i.e. on removal of load, no permanent deformation is observed and the material will regain its original shape and size.

Elastic limit = Error!

- **Yield Point:** Beyond the point B, the material goes to the plastic stage until the upper yield point C is reached i.e. the removal of load does not allow returning the specimen to its original form. Point C is upper yield point.
- **Ultimate Stress Point:** From point E onwards, the strain hardening phenomenon becomes predominant. The stress again starts increasing up to point F because the material picks up the ability to resist increasing stress, but the elongation now increases at much faster rate. Point F is the maximum stress to which the material can be subjected. From point F a material begins to neck and the cross-sectional area starts decreasing at a rapid rate.
- **Breaking Point:** Beyond the point F, elongation will continue at gradually decreasing load and ultimately the material breaks at point G. Point G is known as 'breaking point' or fracture point.

NOMINAL STRESSES

Nominal stress is defined as the force on the object divided by the original area. It will be cleared if we compare the above definition with true stress definition (which is "the force on the object divided by the actual area").

YIELD POINT, PLASTIC STAGE

Yield point

Beyond the point B, the material goes to the plastic stage until the upper yield point C is reached i.e. the removal of load does not allow to return the specimen to its original form. Point C is upper yield point & Point D is lower yield point. At this point the cross-sectional area of the material point

Plastic Stage

A permanent deformation or change in shape of solid body without fracture under the action of sustained force. Small changes in the density of crystals due to plastic deformation.

ULTIMATE STRESS AND BREAKING STRESS

Ultimate Stress

Maximum or ultimate stress of a material is defined as the ratio of the maximum load which a specimen is subjected in a tensile test and the original cross-sectional area of the specimen

$$\text{Ultimate stress} = \text{Error!}$$

Breaking Stress

It is defined as the ratio of the maximum load at which fracture occurs in a specimen subjected to a tensile test and the original cross-sectional area of the specimen.

PERCENTAGE ELONGATION

If L_0 is the original gauge length and L_f is the final length of the specimen, then

$$\text{Percentage elongation} = \text{Error!} * 100$$

PROOF STRESS AND WORKING STRESS

- **Proof Stress**

Proof stress is the stress necessary to cause a permanent extension equal to a defined percentage of gauge length.

- **Working Stress**

In actual practice, the material is not subjected upto ultimate stress, but only upto fraction of ultimate stress. This stress is known as working stress is also known as allowable stress or permissible stress.

$$\text{Working stress} = \text{Error!}$$

FACTOR OF SAFETY

The ratio of ultimate stress and working stress is called factor of safety. It is also known as factor of ignorance.

$$\text{Factor of Safety} = \text{Error!}$$

POISSON'S RATIO

It is the ratio of the proportional decrease in a lateral measurement to the proportional increase in length in a sample of material that is elastically stretched. It is denoted by (μ) or $(1/m)$.

$$\text{Poisson's Ratio, } \left(\frac{1}{m}\right) = \frac{\text{lateral strain}}{\text{longitudinal strain}}$$

THERMAL STRESS AND STRAIN

When the temperature of a body is changed, the change in dimensions takes place. If the member is free to expand or contract, no stresses will be induced. But, if the change in length is prevented, stress is developed in the body. This stress is called thermal stress or temperature stress.

If the length of the bar of uniform section is l , the temperature of body changes from t_1 to t_2 α is the coefficient of linear expansion.

The extensions due to rise in temperature = $\alpha (t_2 - t_1)$.

If the ends of body are fixed to prevent extensions produced due to rise in temperature, the temperature strain = $\alpha(t_2 - t_1)$

LONGITUDINAL AND CIRCUMFERENTIAL STRESSES IN SEAM LESS THIN WALLED CYLINDRICAL SHELLS

- **Longitudinal Stresses**

The stresses which act along the length of the cylinder are called longitudinal or axial stress. Consider a thin cylinder subjected to an internal pressure, which tends to split up in to two pieces.

Let, P is the pressure, f_l is the longitudinal stress induced in the cylinder.

Diameter of shell is d and the thickness is ' t '.

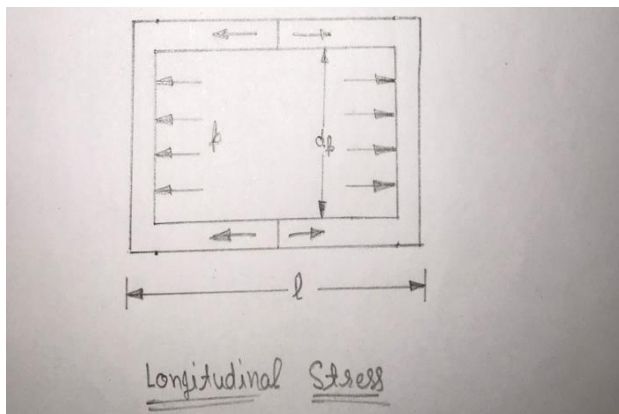

Bursting force = $P \times \text{Area on which } P \text{ acts} = P \times (\pi d^2)$

Resisting force = $\text{Stress} \times \text{Area on which stress acts} = f_l \times (\pi d.t)$

For equilibrium, the bursting force should be equal to resisting force.

i.e. $\text{Bursting} = \text{Resisting force}$

$$\text{or } P \pi d^2 = f_1 \pi X t$$

$$f_1 = \text{Error!}$$

- **Circumferential Stress or Hoop Stress**

The stresses which act along the circumference of the cylinder are called circumferential or hoop stresses. These are also known as tangential stresses. Due to hoop stresses, the cylinder may split up into two troughs. Consider a thin cylindrical shell of internal diameter, d and length, l , and t is the thickness of cylindrical shell.

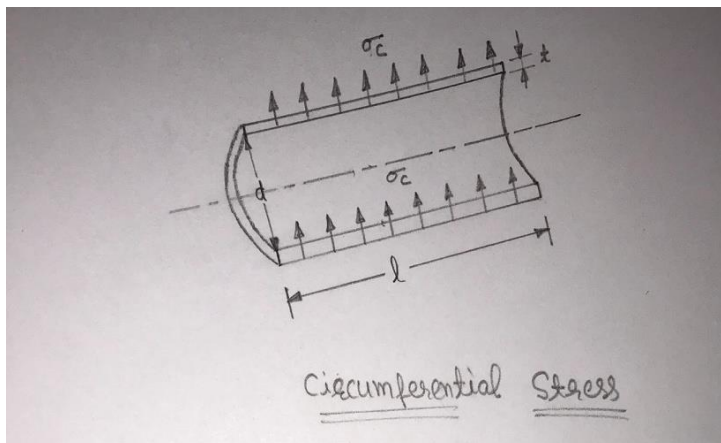

Let the hoop stresses develop due to the internal fluid pressure. The intensity of internal pressure is denoted by P . Due to the internal pressure, the shell may split up into two troughs along XX axis.

Let the hoop stresses developed due to internal fluid pressure is denoted by f_h .

Total bursting force in shell = Intensity of pressure \times Area on which P acts

$$= P \cdot (d \times l)$$

$$\text{Resisting force} = f_h \times \text{Area on which } f_h \text{ is acting}$$

For equilibrium, bursting force must be equal to resisting force.

$$\text{Bursting force} = \text{Resisting force}$$

$$P \cdot d \cdot l = f_h \times 2 \cdot l \cdot t$$

$$F_h = \text{Error!}$$

INTRODUCTION TO PRINCIPAL STRESSES

Principal stress is the maximum normal stress a body can have at its some point. It represents purely normal stress. If at some point principal stress is said to have

acted it does not have any shear stress component. Principal stresses are maximum and minimum value of normal stresses on a plane (when rotated through an angle) on which there is no shear stress. Principal plane is that plane on which the principal stresses act and shear stress is zero.

$$\sigma_{1,2} = \frac{\sigma_x + \sigma_y}{2} \pm \sqrt{\left(\frac{\sigma_x - \sigma_y}{2}\right)^2 + \tau_{xy}^2}$$

END OF THE CHAPTER

2. RESILIENCE

STRAIN ENERGY, RESILIENCE, PROOF RESILIENCE AND MODULUS OF RESILIENCE

➤ **Strain Energy**

The amount of work done in straining the body within elastic limit is called as Strain energy. Strain energy is same as work done. It is denoted by 'U'.

➤ **Resilience**

When an elastic body is subjected to a force it may undergo a linear deformation. The force acts on the body throughout this deformation process. Hence work is done by the force for the deformation. This work done by the force is stored in the material as internal energy (strain energy). This stored energy is used to restore the original shape of the body on removal of force. The energy stored when a body is strained within the elastic limit is known as resilience.

➤ **Proof Resilience**

The strain energy stored in the material will be maximum when it is strained up to the elastic limit. This maximum strain energy stored in the material when it is strained up to the elastic limit is known as Proof resilience.

➤ **Modulus of Resilience**

The Proof resilience per unit volume is known as modulus of resilience. Hence it is the maximum strain energy that can be stored in an elastic material per unit volume.

STRAIN ENERGY DUE TO DIRECT STRESSES AND SHEAR STRESS

2.6 STRAIN ENERGY STORED IN A BODY DUE TO SHEAR STRESS

Let consider a cubical block ABCD of length l whose one face AD is fixed while shear force P is applied on the opposite face BC. Let τ is the shear stress induced and ϕ is the corresponding shear strain. Let G is the modulus of rigidity,

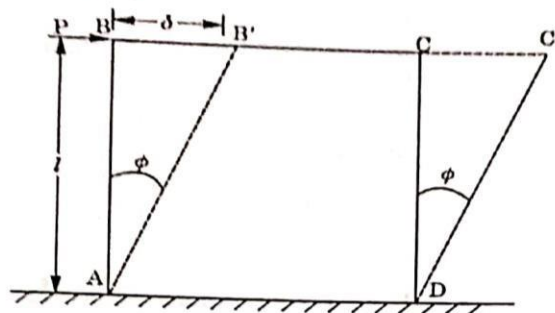

Fig. 2.3 : Strain Energy Stored Due to Shear Stress

As the load P is applied gradually,

$$\therefore \text{Average load} = \frac{0 + P}{2} = \frac{P}{2}$$

Strain energy stored, $U =$ Workdone in deforming the rectangular block
 $=$ Average load \times Deformation

$$= \frac{P}{2} \times CC'$$

$$= \frac{P}{2} \times DC \cdot \phi$$

$$(\because CC' = DC \cdot \phi)$$

$$= \frac{1}{2} \tau \times (BC \times l) \times DC \times \phi$$

$$(\because P = \tau \times BC \times l)$$

$$= \frac{1}{2} \tau \times \phi (BC \times DC \times l)$$

$$= \frac{1}{2} \times \text{Stress} \times \text{Strain} \times \text{Volume}$$

$$= \frac{1}{2} \tau \times \frac{\tau}{C} \times V$$

Where $V =$ Volume of cubical block:

$$\therefore U = \frac{\tau^2}{2C} \times V$$

Modulus of resilience $=$ Strain energy stored per unit volume

$$= \frac{\tau^2}{2C}$$

STRESSES DUE TO GRADUAL, SUDDEN AND FALLING LOAD

➤ Strain Energy due to Gradual applied Load

Let us consider a body which is subjected with tensile load which is increasing gradually up to its elastic limit from value 0 to value P and therefore

deformation or extension of the body is also increasing from 0 to x and we can see it in following load extension diagram as displayed here.

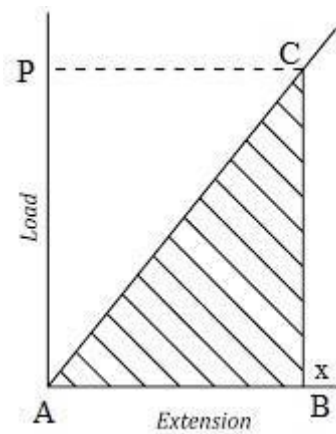

σ = Stress developed in the body

E = Young's Modulus of elasticity of the material of the body

A = Cross sectional area of the body

P = Gradually applied load which is increasing gradually up to its elastic limit from value 0 to value P

$$P = \sigma \cdot A$$

x = Deformation or extension of the body which is also increasing from 0 to x

L = Length of the body

V = Volume of the body = $L \cdot A$

U = Strain energy stored in the body

As we have already discussed that when a body will be loaded within its elastic limit, the work done by the load in deforming the body will be equal to the strain energy stored in the body.

Strain energy stored in the body = Work done by the load in deforming the body

Strain energy stored in the body = Area of the load extension curve

Strain energy stored in the body = Area of the triangle ABC

$$U = (1/2) \cdot AB \cdot BC$$

$$U = (1/2) x \cdot P$$

Let us use the value of $P = \sigma \cdot A$, which is determined above

$$U = (1/2) x \cdot \sigma \cdot A$$

As, $x = \sigma \cdot L / E$

Therefore strain energy stored in a body, when load will be applied gradually, will be given by following equation.

$$\frac{\sigma^2}{2E} \times V$$

➤ **Strain Energy due to Suddenly applied Load**

Let us see the load extension diagram as displayed here for this case where body will be subjected with sudden load and we will find out here the stress induced in the body due to sudden applied load and simultaneously we will also secure the expression for strain energy for this situation.

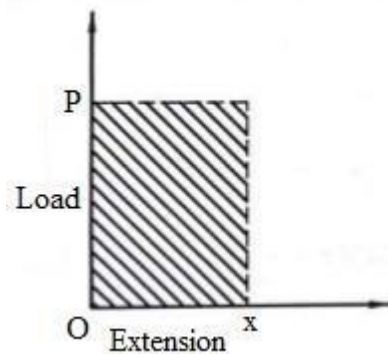

σ = Stress developed in the body due to sudden applied load

E = Young's Modulus of elasticity of the material of the body

A = Cross sectional area of the body

P = Sudden applied load which will be constant throughout the deformation process of the body

x = Deformation or extension of the body

L = Length of the body

V = Volume of the body = $L.A$

U = Strain energy stored in the body

Strain energy stored in the body = Work done by the load in deforming the body

Strain energy stored in the body = Area of the load extension curve

Strain energy stored in the body = $P \cdot x$

$U = P \cdot x$

As we know that maximum strain energy stored in the body U will be provided by the following expression as mentioned here.

$$U = \frac{\sigma^2}{2E} \times V$$

$$U = \frac{\sigma^2}{2E} \times A \cdot L$$

$$P \cdot x = \frac{\sigma^2}{2E} \times A \cdot L$$

$$P \times \frac{\sigma}{E} \times L = \frac{\sigma^2}{2E} \times A \cdot L$$

$$P = \sigma \times A / 2$$

$$\sigma = 2P/A$$

Therefore, we can say here that maximum stress induced in the body due to sudden applied load will be twice the stress induced in the body with same value of load applied gradually.

➤ Strain Energy due to impact applied Load

Let us see the following figure, where we can see one vertical bar which is fixed at the upper end and there is collar at the lower end of the bar. Let us think that one load is being dropped over the collar of the vertical bar from a height of h as displayed in following figure

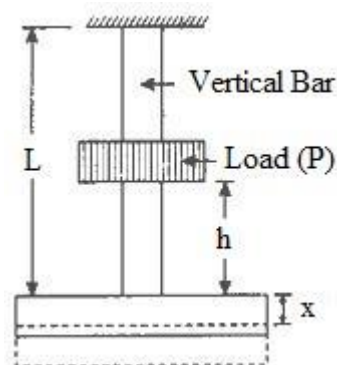

Let us go ahead step by step for easy understanding, however if there is any issue we can discuss it in comment box which is provided below this post.

We have following information from above figure where a body is subjected with an impact load.

σ = Stress developed in the body due to impact load

E = Young's Modulus of elasticity of the material of the body

A = Cross sectional area of the body

P = Impact load

x = Deformation or extension of the body i.e. vertical bar

L = Length of the body i.e. vertical bar

V = Volume of the body i.e. vertical bar = L.A

U = Strain energy stored in the body i.e. vertical bar

Strain energy stored in the vertical bar = Work done by the load in deforming the vertical bar

Strain energy stored in the vertical bar = Load x Displacement

Strain energy stored in the vertical bar = P. (h + x)

U = P. (h + x)

As we know that strain energy stored in the body U will be provided by the following expression as mentioned here.

$$U = \frac{\sigma^2}{2E} \times V$$

$$U = \frac{\sigma^2}{2E} \times A \cdot L$$

Therefore, we will have

$$P \cdot (h + x) = \frac{\sigma^2}{2E} \times A \cdot L$$

Let use the value of the extension or deformation “x” in above equation and we will have.

$$\begin{aligned} P \left(h + \frac{\sigma L}{E} \right) &= \frac{1}{2} \cdot \frac{\sigma^2}{E} (A \times L) \\ Ph + \frac{P \cdot \sigma L}{E} &= \frac{\sigma^2}{2E} (AL) \\ \frac{\sigma^2}{2E} - \frac{P \cdot \sigma}{A \cdot E} &= \frac{P \cdot h}{A \cdot L} \\ \sigma^2 - \frac{2P\sigma}{A} &= \frac{2PhE}{A \cdot L} \\ \sigma^2 - \frac{2P\sigma}{A} + \frac{P^2}{A^2} &= \frac{2PhE}{A \cdot L} + \frac{P^2}{A^2} \\ \left(\sigma - \frac{P}{A} \right)^2 &= \frac{P^2}{A^2} + \frac{2 \cdot P \cdot h \cdot E}{A \cdot L} \\ \left(\sigma - \frac{P}{A} \right) &= \sqrt{\frac{P^2}{A^2} + \frac{2P \cdot h \cdot E}{A \cdot L}} \\ \sigma &= \frac{P}{A} + \sqrt{\frac{P^2}{A^2} + \frac{2P \cdot h \cdot E}{A \cdot L}} \end{aligned}$$

END OF THE CHAPTER

3. MOMENT OF INERTIA

CONCEPT OF MOMENT OF INERTIA AND SECOND MOMENT OF AREA

- **Moment Of Inertia**

The product of the mass and the square of the distance of the center of gravity from an axis are known as moment of the inertia. The moment of inertia is represented by “I”.

The value of the moment of inertia is always positive, regardless of location of the axis. Units are such as kgmm^2 or kgm^2 .

Moments of inertia for the entire area A about the x and y axes are

$$I_x = \sum y^2 dm \text{ and } I_y = \sum x^2 dm.$$

- **Second Moment of Area**

The product of the area and the square of the distance of the centroid from an axis are known as second moment of the area. The second area moment of is represented by “I”.

Units are length to the 4th power, such as mm^4 or m^4 .

Moments of inertia for the entire area A about the x and y axes are

$$I_x = \sum y^2 dA \text{ and } I_y = \sum x^2 dA.$$

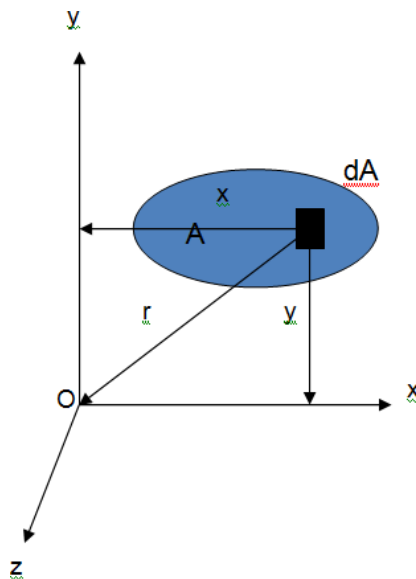

RADIUS OF GYRATION

Radius of gyration of a body about an axis of rotation is defined as the radial distance of a point from the axis of rotation at which, if whole mass of the body is assumed to be concentrated, its moment of inertia about the given axis would be the same as with its actual distribution of mass.

Mathematically, the radius of gyration is the root mean square distance of the object's parts from either its center of mass or a given axis, depending on the relevant application. It is actually the perpendicular distance from point mass to the axis of rotation.

Consider area A with moment of inertia I_x . Imagine that the area is concentrated in a thin strip parallel to the x axis with equivalent I_x .

$$I_x = k_x^2 A \quad k_x = \sqrt{\frac{I_x}{A}}$$

k_x = Radius of gyration with respect to the x axis

THEOREM OF PERPENDICULAR AXIS AND PARALLEL AXIS (WITH DERIVATION)

- **Theorem of Perpendicular Axis**

The theorem states that the M.O.I of any figure about the axis perpendicular to mutually perpendicular axis is equal to sum of M.O.I about these two axes of the same figure.

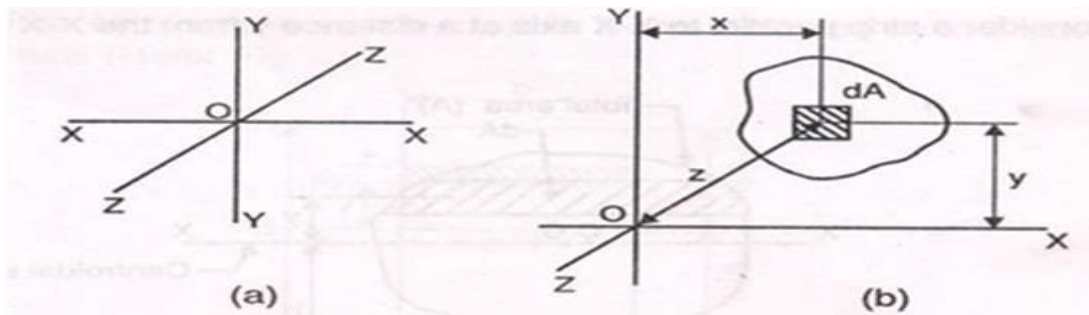

Proof. Consider an elementary area dA , at a distance x from Y-Y axis and y from X-X axis and z from Z-Z axis. Z-Z axis is an axis perpendicular to X-X and Y-Y as shown in the Fig. 2.

By Pythagoras theorem,

$$z^2 = x^2 + y^2$$

Moment of inertia of an elementary area about Z-Z axis

$$= z^2 \cdot dA = (x^2 + y^2) \cdot dA = x^2 \cdot dA + y^2 \cdot dA$$

Total moment of inertia of the whole section about Z-Z axis,

$$I_{ZZ} = \Sigma x^2 \cdot dA + \Sigma y^2 \cdot dA$$

$$\text{But } \Sigma x^2 \cdot dA = I_{YY}$$

$$\text{and, } \Sigma y^2 \cdot dA = I_{XX}$$

$$\therefore I_{ZZ} = I_{XX} + I_{YY}$$

Z-Z axis is called **polar axis** and I_{ZZ} is known as **polar moment of inertia**. Polar moment of inertia is useful in analysing the torsional stresses.

Polar moment of inertia is also denoted by I_p .

- **Theorem of Parallel Axis**

The parallel axis theorem states that the M.O.I of an area about any axis is equal to the M.O.I of the area about its own centroid, plus the product of the area & the square of the distance between the centroid of the area & the axis about which M.O.I is required

Mathematically, it is given by

$$I_{AB} = I_G + Ah^2$$

where I_{AB} = Moment of inertia of the given area about AB

I_G = Moment of inertia of the given area about its own centroid

A = Area of the section

h = Distance between the centroid of the section and the axis AB.

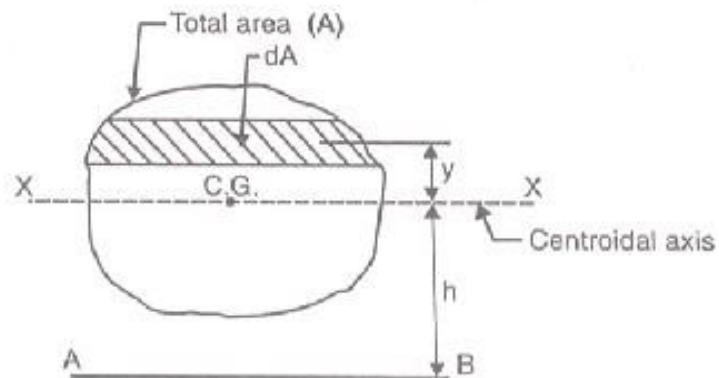

Let the area of strip = dA

Moment of inertia of area dA about X-X axis = $dA \cdot y^2$

\therefore Moment of inertia of the total area about X-X axis, I_{XX} or $I_G = \Sigma dA \cdot y^2$

Moment of inertia of the area dA about AB

$$= dA \cdot (h + y)^2 = dA \cdot (h^2 + y^2 + 2hy)$$

\therefore Moment of inertia of the total area about AB,

$$I_{AB} = \Sigma dA \cdot (h^2 + y^2 + 2hy) \\ = \Sigma dA \cdot h^2 + \Sigma dA \cdot y^2 + \Sigma dA \cdot 2hy$$

or $I_{AB} = h^2 \Sigma dA + \Sigma dA \cdot y^2 + 2h \Sigma dA \cdot y$ (\because h or h^2 is constant)

or $I_{AB} = h^2 A + I_G + 2h \Sigma dA \cdot y$ (i)

($\because \Sigma dA = A$ and $\Sigma dA \cdot y^2 = I_G$)

$\Sigma dA \cdot y$ represents the moment of the total area about X-X axis. As the distance of the centroid of the total area from X-X is zero, hence $\Sigma dA \cdot y$ will be equal to zero.

Substituting $\Sigma dA \cdot y = 0$ in equation (i), we get

$$I_{AB} = Ah^2 + I_G + 0$$

or $I_{AB} = I_G + Ah^2$

SECOND MOMENT OF AREA OF COMMON GEOMETRICAL SECTIONS RECTANGLE, TRIANGLE, CIRCLE (WITHOUT DERIVATION)

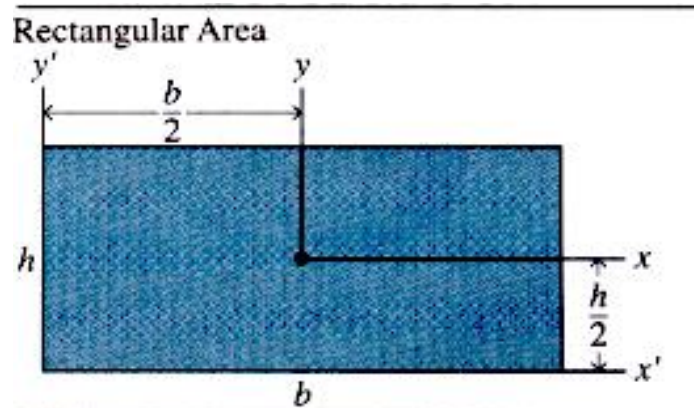

$$A = bh$$

$$I_x = \frac{bh^3}{12}$$

$$I_{x'} = \frac{bh^3}{3}$$

$$I_y = \frac{hb^3}{12}$$

$$I_{y'} = \frac{hb^3}{3}$$

$$I_{xy} = 0$$

$$I_{x'y'} = \frac{b^2h^2}{4}$$

Triangular Area

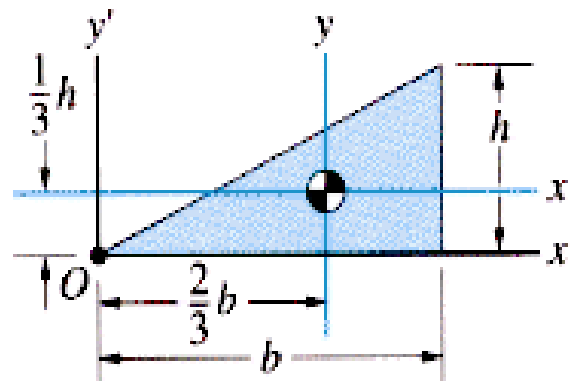

$$A = \frac{1}{2}bh$$

$$I_x = \frac{bh^3}{36}$$

$$I_{x'} = \frac{bh^3}{12}$$

$$I_y = \frac{hb^3}{36}$$

$$I_{y'} = \frac{hb^3}{4}$$

$$I_{xy} = \frac{b^2h^2}{72}$$

$$I_{x'y'} = \frac{b^2h^2}{8}$$

Circular Area

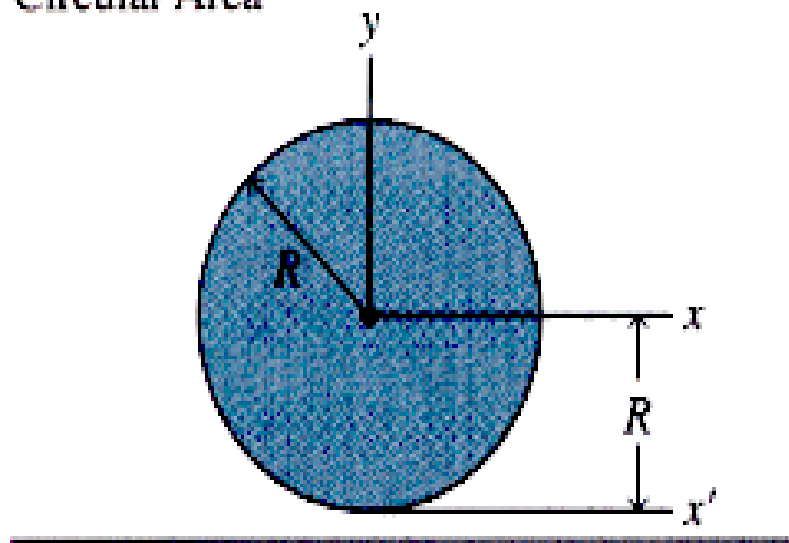

$$A = \pi R^2$$

$$I_x = \frac{\pi R^4}{4}$$

$$I_{x'} = \frac{5\pi R^4}{4}$$

$$I_y = \frac{\pi R^4}{4}$$

$$I_{xy} = 0$$

Semicircular Area

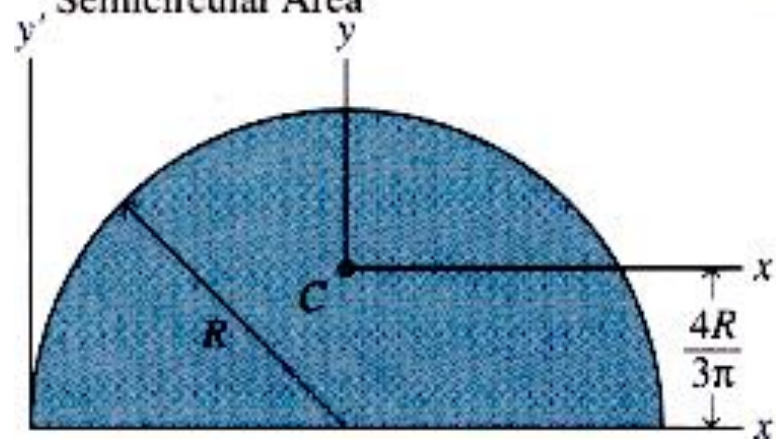

$$A = \frac{1}{2} \pi R^2$$

$$I_x = \frac{\pi R^4}{8} - \frac{8R^4}{9\pi}$$

$$I_{x'} = \frac{\pi R^4}{8}$$

$$I_y = \frac{\pi R^4}{8}$$

$$I_{xy} = 0$$

$$I_{x'y'} = \frac{2R^4}{3}$$

Quarter-
Circular
Area

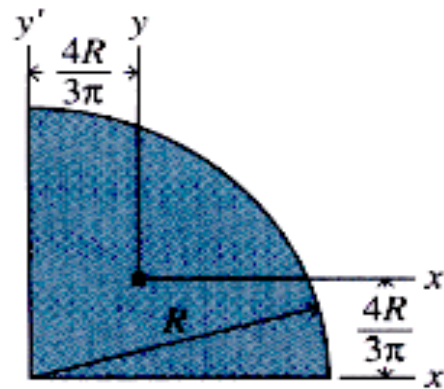

$$A = \frac{1}{4} \pi R^2$$

$$I_x = \frac{\pi R^4}{16} - \frac{4R^4}{9\pi}$$

$$I_{x'} = \frac{\pi R^4}{16}$$

$$I_{y'} = \frac{\pi R^4}{16}$$

Ellipse

$$I_{xy} = \frac{(9\pi - 32)R^4}{72\pi}$$

$$I_{x'y'} = \frac{R^4}{8}$$

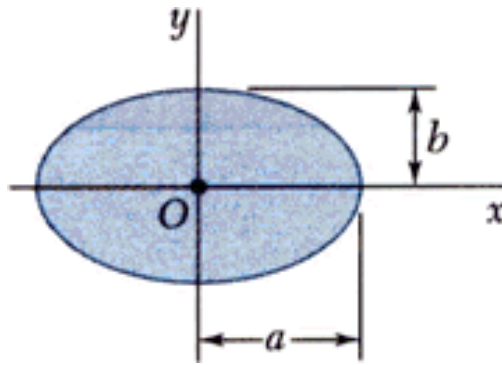

$$\bar{I}_x = \frac{1}{4} \pi a b^3$$

$$\bar{I}_y = \frac{1}{4} \pi a^3 b$$

SECOND MOMENT OF AREA FOR L,T AND I SECTION,SECTION MODULUS

- Second Moment Of Area For L,T And I

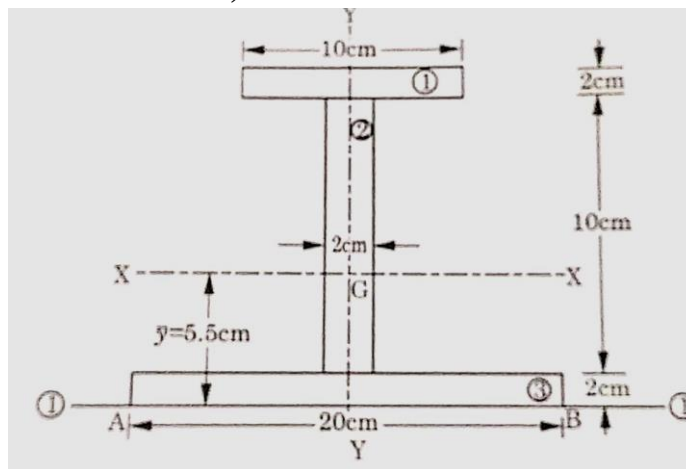

Component	Area (Λ) (cm^2)	Centroidal Distance y from Axis 1-1 (cm)	Λy (cm^3)	Λy^2 (cm^4)	I_{self} (cm^4)
1	20	13	260	3380	$\frac{10 \times 2^3}{12} = 6.67$
2	20	7	140	980	$\frac{2 \times (10)^3}{12} = 166.67$
3	40	1	40	40	$\frac{20 \times 2^3}{12} = 13.33$
	$\Sigma \Lambda = 80$		$\Sigma \Lambda y = 440$	$\Sigma \Lambda y^2 = 4400$	$\Sigma I_{\text{self}} = 186.67$

Distance of centroidal axis XX from axis 1-1,

$$\bar{y} = \frac{\Sigma \Lambda y}{\Sigma \Lambda} = \frac{440}{80} = 5.5 \text{ cm}$$

$$I_{1-1} = \Sigma I_{\text{self}} + \Sigma \Lambda y^2$$

$$= 186.67 + 4400 = 4586.67 \text{ cm}^4$$

But

$$I_{1-1} = I_{XX} + (\Sigma \Lambda) \cdot \bar{y}^2$$

$$4586.67 = I_{XX} + 80 \times (5.5)^2$$

or

$$I_{XX} = 2166.67 \text{ cm}^4 \text{ Ans.}$$

$$I_{YY} = \frac{2 \times (10)^3}{12} + \frac{10 \times 2^3}{12} + \frac{2 \times (20)^3}{12} = 1506.67 \text{ cm}^4 \text{ Ans.}$$

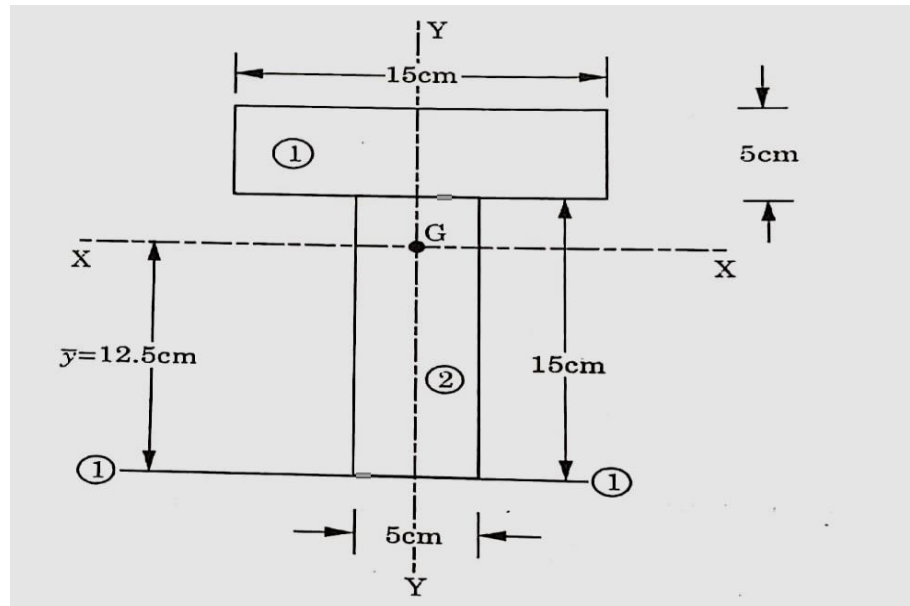

Solution. Let us split this T-section into two components- Component (1) and component (2). As this section is symmetrical about YY-axis, therefore, the centroid will lie on this axis.

Component	Area (A) (cm ²)	Centroidal Distance y from Axis 1-1 (cm)	Ay (cm ³)	Ay ² (cm ⁴)	I _{self} (cm ⁴)
1	75	17.5	1312.5	22968.75	$\frac{15 \times (5)^3}{12} = 156.25$
2	75	7.5	562.5	4218.75	$\frac{5 \times (15)^3}{12} = 1406.25$
	ΣA = 150		ΣAy = 1875	ΣAy ² = 27187.5	Σ I _{self} = 1562.5

Distance of centroidal axis from axis 1-1,

$$\bar{y} = \frac{\Sigma Ay}{\Sigma A}$$

$$= \frac{1875}{150} = 12.5 \text{ cm}$$

$$I_{1-1} = \Sigma I_{\text{self}} + \Sigma Ay^2$$

$$= 1562.5 + 27187.5$$

$$= 28750 \text{ cm}^4$$

But

$$I_{1-1} = I_{XX} + (\Sigma A) \cdot \bar{y}^2$$

$$28750 = I_{XX} + 150 \times (12.5)^2$$

or

$$I_{XX} = 5312.5 \text{ cm}^4 \text{ Ans.}$$

$$I_{YY} = \frac{5 \times (15)^3}{12} + \frac{15 \times (5)^3}{12}$$

$$= 1562.5 \text{ cm}^4 \text{ Ans.}$$

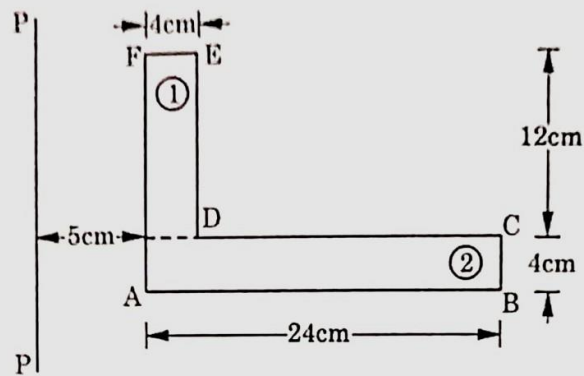

Fig. 3.16

Solution. Let us divide the given section into two rectangles : (1) and (2) and calculate the moment of inertia of each about axis P-P with the help of theorem of parallel axis.

M.O.I. of rectangle (1) about P-P axis,

$$I_{PP_1} = \frac{12 \times 4^3}{12} + (12 \times 4)(5 + 2)^2$$

$$= 64 + 48 \times 49 = 2416 \text{ cm}^4$$

M.O.I. of rectangle (2) about P-P axis,

$$I_{PP_2} = \frac{4 \times 24^3}{12} + (4 \times 24)(5 + 12)^2$$

$$= 4608 + 96 \times 289 = 32352 \text{ cm}^4$$

Hence M.O.I of given section about P-P axis,

$$I_{PP} = I_{PP_1} + I_{PP_2}$$

$$= 2416 + 32352 = 34768 \text{ cm}^4 \text{ Ans.}$$

• Section Modulus

It is defined as the ratio of M.O.I of a section about its neutral axis to the distance of the outermost layer or extreme edge from the neutral axis. It is denoted by "Z".

$$Z = \frac{I}{y}$$

Where I = M.O.I about centroidal axis (neutral axis).

y = Distance of the outer most layer from centroidal axis.

END OF THE CHAPTER

4. BENDING MOMENT AND SHEARING FORCE

CONCEPT OF VARIOUS TYPES OF BEAMS AND FORM OF LOADING

➤ **Beam**

A beam is a structural member used for bearing loads. It is typically used for resisting vertical loads, shear forces and bending moments.

➤ **Types of Beam**

- simply supported beam
- Cantilever beam
- Overhanging beam
- Continuous beam
- Fixed beam

- **Simply Supported Beam:** A simply supported beam is a type of beam that has pinned support at one end and roller support at the other end. Depending on the load applied, it undergoes shearing and bending. It is the one of the simplest structural elements in existence.



Simply Supported Beam

- **Cantilever Beam:** Cantilever beams a structure member of which one end is fixed and other is free. This is one of the famous type of beam use in trusses, bridges and other structure member. This beam carry load over the span which undergoes both shear stress and bending moment.



Cantilever Beam

- **Overhanging Beam:** Overhanging beam is combination of simply supported beam and cantilever beam. One or both of end overhang of this beam. This beam is supported by roller support between two ends. This type of beam has heritage properties of cantilever and simply supported beam.

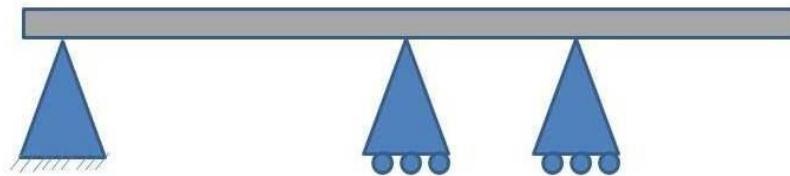

Overhanging Beam

- **Continuous Beam:** This beam is similar to simply supported beam except more than two support are used on it. One end of it is supported by hinged support and other one is roller support. One or more supports are use between these beams. It is used in long concrete bridges where length of bridge is too large.

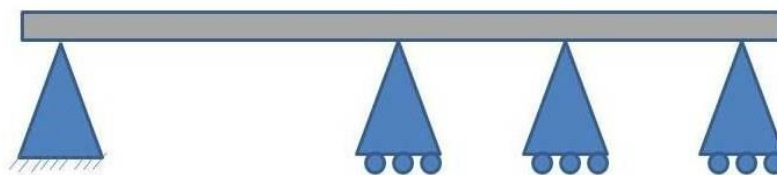

Continuous Beam

- **Fixed Beam:** This beam is fixed from both ends. It does not allow vertical movement and rotation of the beam. It is only under shear stress and no moment produces in this beams. It is used in trusses, and other structure.



Fixed Beam

➤ **Types of Loading**

A beam is usually horizontal member and load which will be acting over the beam will be usually vertical loads. There are following types of loads as mentioned here and we will discuss each type of load in detail.

- ❖ Point load or concentrated load
- ❖ Uniformly distributed load
- ❖ Uniformly varying load

▪ **Point load or concentrated load:**

Point load or concentrated load, as name suggest, acts at a point on the beam. If we will see practically, point load or concentrated load also distributed over a small area but we can consider such type of loading as point loading and hence such type of load could be considered as point load or concentrated load.

Following figure displayed here indicates the beam AB of length L which will be loaded with point load W at the midpoint of the beam. Load W will be considered here as the point load.

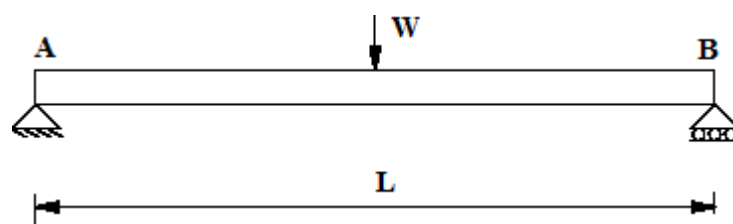

▪ **Uniformly distributed load:**

Uniformly distributed load is the load which will be distributed over the length of the beam in such a way that rate of loading will be uniform throughout the distribution length of the beam. Uniformly distributed load is also expressed as U.D.L and with value as w N/m. During determination of the total load, total uniformly distributed load will be converted in to point load by multiplying the rate of loading i.e. w (N/m) with the span of load distribution i.e. L and will be acting over the midpoint of the length of the uniformly load distribution.

Let us consider the following figure, a beam AB of length L is loaded with uniformly distributed load and rate of loading is w (N/m).

Total uniformly distributed load, $P = w \cdot L$

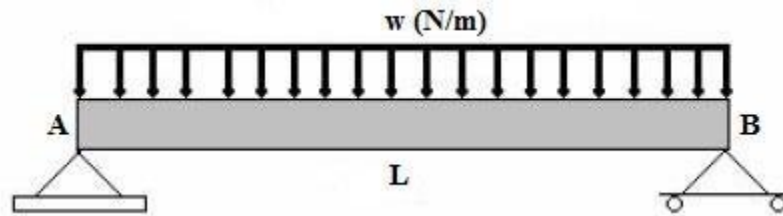

▪ **Uniformly varying load:**

Uniformly varying load is the load which will be distributed over the length of the beam in such a way that rate of loading will not be uniform but also vary from point to point throughout the distribution length of the beam. Uniformly varying load is also termed as triangular load. Let us see the following figure, a beam AB of length L is loaded with uniformly varying load. We can see from figure that load is zero at one end and increases uniformly to the other end. During determination of the total load, we will determine the area of the triangle and the result i.e. area of the triangle will be total load and this total load will be assumed to act at the C.G of the triangle.

Total load, $P = w \cdot L / 2$

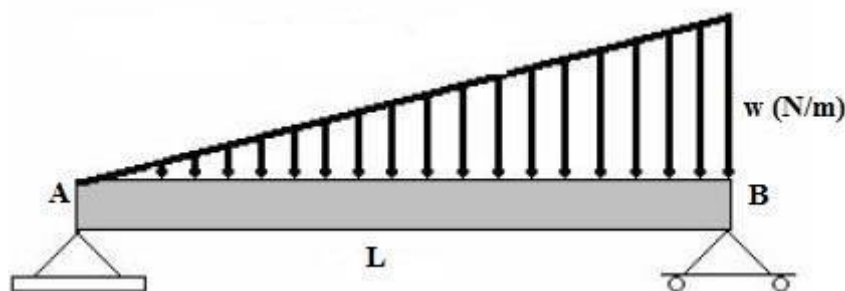

CONCEPT OF END SUPPORTS-ROLLER, HINGED AND FIXED

➤ **Beam**

A beam is a structural member used for bearing loads. It is typically used for resisting vertical loads, shear forces and bending moments.

➤ Types of End Support

• Roller supports

Roller support allows thermal expansion and contraction of the span and prevents damage on other structural members such as a pinned support. The typical application of Roller supports is in large bridges. In civil engineering, roller supports can be seen at one end of a bridge.

Roller support cannot prevent translational movements in horizontal or lateral directions and any rotational movement but prevents vertical translations. Its reaction force is a single linear force perpendicular to, and away from, the surface (upward or downward). This support type is assumed to be capable of resisting normal displacement.



• Pinned support

Pinned support attaches the only web of a beam to a girder called a shear connection. The support can exert a force on a member acting in any direction and prevent translational movements, or relative displacement of the member-ends in all directions but cannot prevent any rotational movements. Its reaction forces are single linear forces of unknown direction or horizontal and vertical forces which are components of the single force of unknown direction.[5]

Pinned support is just like a human elbow. It can be extended and flexed (rotation), but you cannot move your forearm left to right (translation). One benefit of pinned supports is not having internal moment forces and only their axial force playing a big role in designing them.



➤ **Fixed support**

Rigid or fixed supports maintain the angular relationship between the joined elements and provide both force and moment resistance. It exerts forces acting in any direction and prevents all translational movements (horizontal and vertical) as well as all rotational movement of a member. These supports' reaction forces are horizontal and vertical components of a linear resultant; a moment.[5] It is a rigid type of support or connection. The application of the fixed support is beneficial when we can only use single support, and people most widely used this type as the only support for a cantilever. They are common in beam-to-column connections of moment-resisting steel frames and beam, column and slab connections in concrete frames.



CONCEPT OF BENDING MOMENT AND SHEARING FORCE

➤ **Bending Moment**

It may be defined as the algebraic sum of the moments of all vertical forces either to the left or to the right of a section. A B.M. causing concavity upwards will be taken as negative and called as sagging B.M. Similarly, a B.M. causing convexity upwards will be taken as positive and called hogging. Bending moment diagram i.e. BMD will tell you the variation of bending moment throughout the length of the beam.

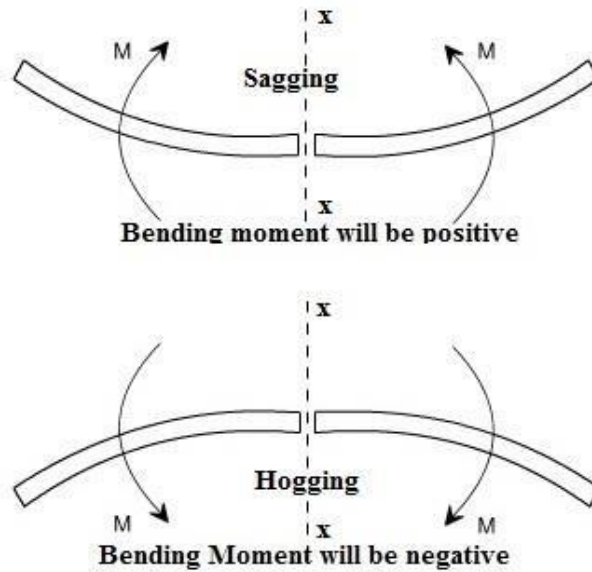

➤ **Shear Force**

It may be defined as the algebraic sum of all vertical forces either to the left or to the right hand side of a section. Shear force having an upward direction to the right hand side of a section or downwards to the left of the section will be taken positive. Similarly, a negative S.F. will be one that has a downward direction to the right of the section or upward direction to the left of the section. Shear force diagram i.e. SFD will tell you the variation of shear force along the length of the beam.

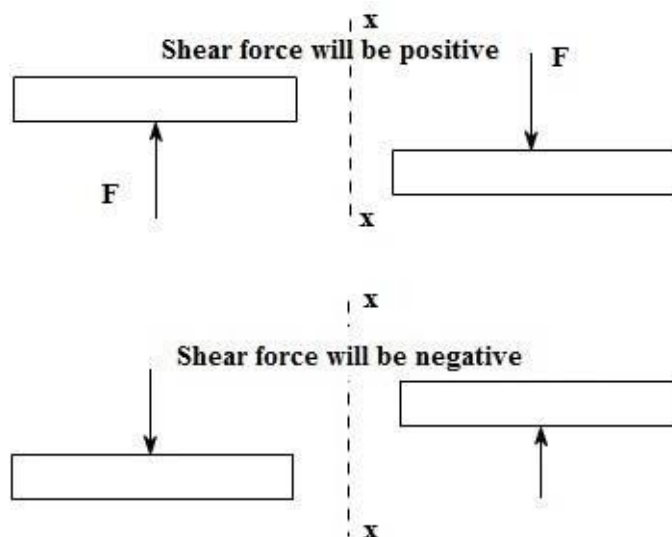

B.M. AND S.F. DIAGRAM FOR CANTILEVER AND SIMPLY SUPPORTED BEAMS WITH AND WITHOUT OVERHANG SUBJECTED TO CONCENTRATED AND U.D.L

➤ **Simply Supported Beam : U.D.L. over the whole span**

A beam, Simply Supported Beam : U.D.L. over the whole span is a structural element that primarily resists loads applied laterally to the beam's axis. Its mode of deflection is primarily by bending.

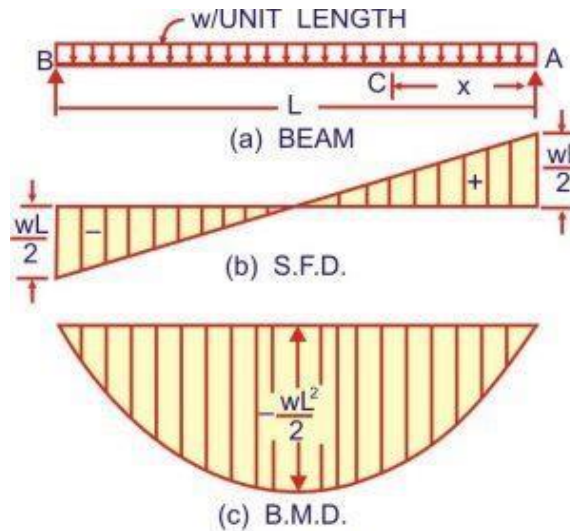

Fig. 3.18.

The reaction $R_A = R_B = \frac{wL}{2}$ (due to symmetry)

S.F.D. : $F_x = +R_A - wx = \frac{wL}{2} - wx$ (linear)

At $x=0$, $F_A = +\frac{wL}{2}$; At $x = \frac{L}{2}$, $F = 0$

At $x=L$, $F_B = +\frac{wL}{2} - wL = -\frac{wL}{2}$

B.M.D. : $M_x = -R_A \cdot x + wx \cdot \frac{x}{2} = -\frac{wL}{2}x + \frac{wx^2}{2}$ (parabolic)

At $x=0$, $M_A=0$; At $x=L$, $M_B=0$

At $x = \frac{L}{2}$, $M = -\frac{wL}{2} \cdot \frac{L}{2} + \frac{w}{2} \left(\frac{L}{2}\right)^2 = -\frac{wL^2}{8}$

➤ **Bending moment and shear force diagram of a cantilever beam**

Cantilever : Point Load at the End

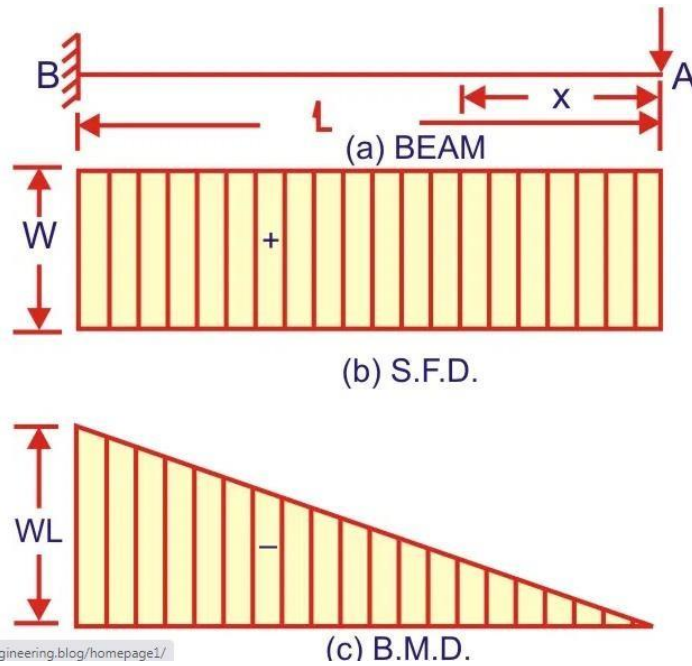

At section x from the end A, $F_x = - W$ and is constant for any position of the section. The S.F.D. will, therefore, be rectangle of height W. Bending moment at a section x from end A is given by:

$$M_x = + W, x \quad \dots\dots\dots(\text{straight line})$$

At $x=0$, $M_A=0$; $x=L$, $M_B=WL$.

The B.M.D. will thus be a triangle having zero ordinate at A and WL at B.

Cantilever : Several Point Loads

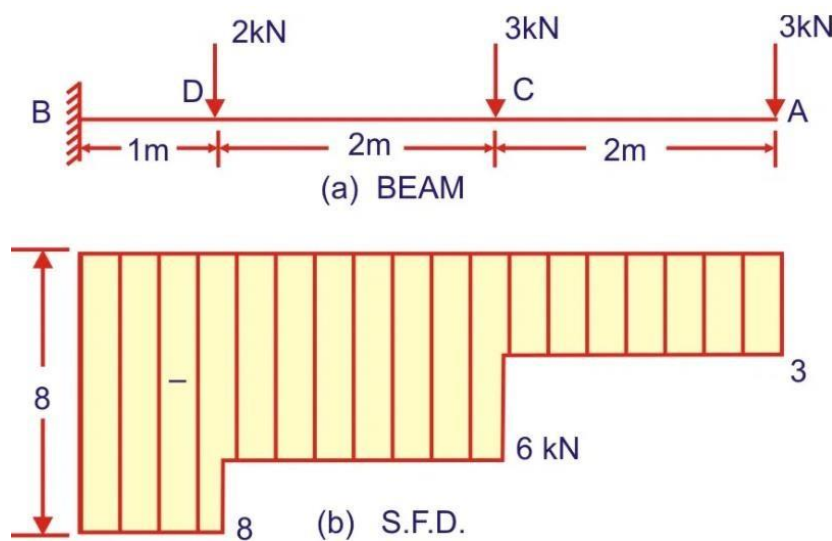

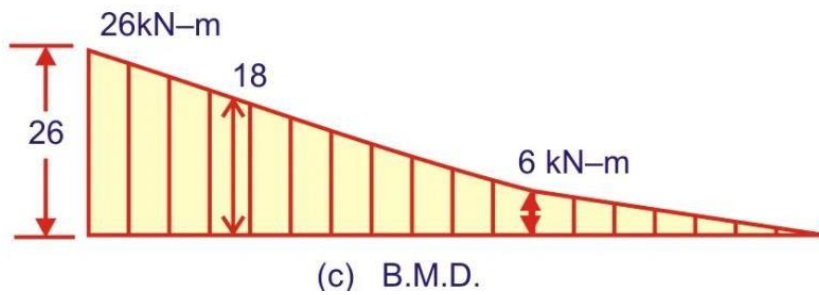

S.F.D. : Between A and C,

$$F_x = -3 \text{ kN (constant)}$$

Between C and D,

$$F_x = -3-3=-6 \text{ kN (constant)}$$

Between D and B,

$$F_x = -3-3-2=-8 \text{ kN (constant)}$$

The S.F.D. will, therefore, consist of several rectangles having different ordinates,

B.M.D. : Between A and C,

$$M_x = 3x \quad \dots \text{ (linear)}$$

When $x=0$, $M_A=0$. When $x=2\text{m}$, $M_C=3 \times 2=6 \text{ kN.m}$

Between C and D.

$$M_x = 3x+3(x-2) \quad \dots \text{ (linear)}$$

When $x=2$, $M_C=6 \text{ kN.m}$ (as before)

When $x=4$, $M_D=(3 \times 4)+(3 \times 2)=18 \text{ kN.m}$

Between D and B,

$$M_x = 3x+3(x-2)+2(x-4) \quad \dots \text{ (linear)}$$

When $x=4$, $M_D=12+6=18 \text{ kN.m}$ (as before)

When $x=5$, $M_B=15+9+2=26 \text{ kN.m}$.

5. BENDING STRESSES

CONCEPT OF BENDING STRESSES

Bending stress is the normal stress that is induced at a point in a body subjected to loads that cause it to bend. When a load is applied perpendicular to the length of a beam (with two supports on each end), bending moments are induced in the beam.

Normal Stress

A normal stress is a stress that occurs when a member is loaded by an axial force. The value of the normal force for any prismatic section is simply the force divided by the cross sectional area

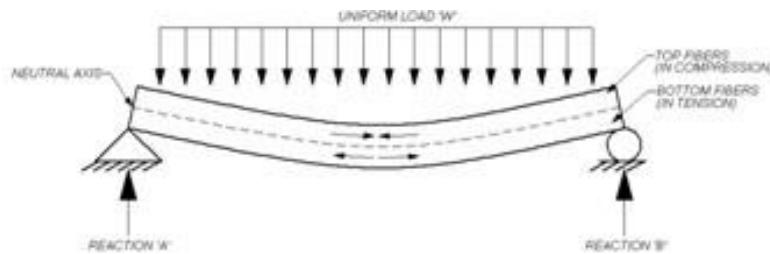

Figure 1-Beam diagram

THEORY OF SIMPLE BENDING, DERIVATION OF BENDING EQUATION

Pure Bending Stress

Bending will be called as pure bending when it occurs solely because of coupling on its end. In that case there is no chance of shear stress in the beam. But, the stress that will propagate in the beam as a result will be known as normal stress. Normal stress because it not causing any damages to beam.

Assumptions in the Theory of Bending Equation:

1. Material of beam is homogenous and isotropic.
2. Young's modulus is constant in compression and tension.
3. Transverse section which are plane before bending before bending remain plain after bending.
4. Beam is initially straight and all longitudinal filaments bend in circular arcs.
5. Radius of curvature is large compared with dimension of cross sections.

6. Each layer of the beam is free to expand or contract

Derivation of Bending Equation

Let us assume that following beam PQ is horizontal and supported at its two extreme ends i.e. at end P and at end Q, therefore we can say that we have considered here the condition of simply supported beam.

Now let us consider one small portion of the beam PQ, which is subjected to a simple bending, as displayed here in following figure. Let us consider two sections AB and CD as shown in following figure

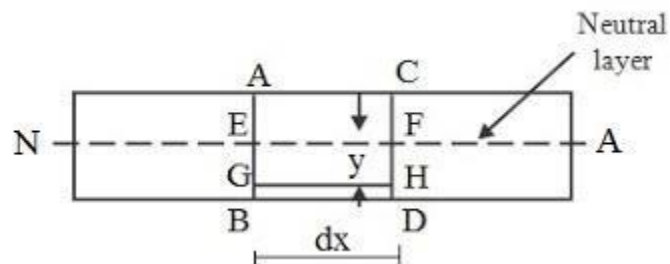

Now we have following information from the above figure.

AB and CD: Two vertical sections in a portion of the considered beam

N.A: Neutral axis which is displayed in above figure

EF: Layer at neutral axis

dx = Length of the beam between sections AB and CD

Let us consider one layer GH at a distance y below the neutral layer EF. We can see here that length of the neutral layer and length of the layer GH will be equal and it will be dx .

Original length of the neutral layer EF = Original length of the layer GH = dx

Now we will analyze here the condition of assumed portion of the beam and section of the beam after bending action and we have displayed here in following figure

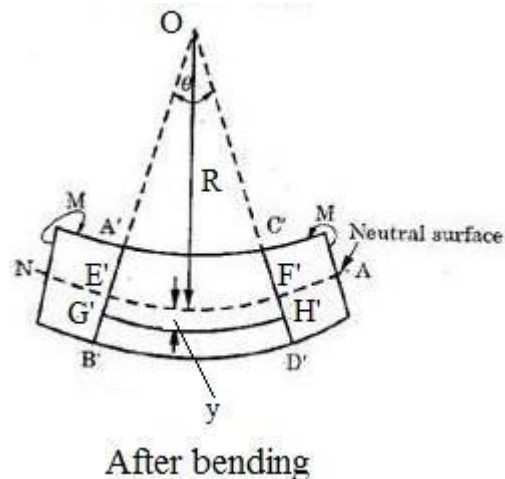

As we can see here that portion of the beam will be bent in the form of a curve due to bending action and hence we will have following information from above figure.

Section AB and CD will be now section A'B' and C'D'

Similarly, layer GH will be now G'H' and we can see here that length of layer GH will be increased now and it will be now G'H'

Neutral layer EF will be now E'F', but as we have discussed during studying of the various assumptions made in theory of simple bending,

Length of the neutral layer EF will not be changed.

Length of neutral layer EF = E'F' = dx

A'B' and C'D' are meeting with each other at center O as displayed in above figure

Radius of neutral layer E'F' is R as displayed in above figure

Angle made by A'B' and C'D' at center O is θ as displayed in above figure

Distance of the layer G'H' from neutral layer E'F' is y as displayed in above figure

Length of the neutral layer E'F' = $R \times \theta$

Original length of the layer GH = Length of the neutral layer EF = Length of the neutral layer E'F' = $R \times \theta$

Length of the layer G'H' = $(R + y) \times \theta$

As we have discussed above that length of the layer GH will be increased due to bending action of the beam and therefore we can write here the following equation to secure the value of change in length of the layer GH due to bending action of the beam.

Change in length of the layer GH = Length of the layer G'H' - original length of the layer GH

Change in length of the layer GH = $(R + y) \times \theta - R \times \theta$

Change in length of the layer GH = $y \times \theta$

Strain in the length of the layer GH = Change in length of the layer GH / Original length of the layer GH

Strain in the length of the layer GH = $y \times \theta / R \times \theta$

Strain in the length of the layer GH = y/R

As we can see here that strain will be directionally proportional to the distance y i.e. distance of the layer from neutral layer or neutral axis and therefore as we will go towards bottom side layer of the beam or towards top side layer of the beam, there will be more strain in the layer of the beam.

At neutral axis, value of y will be zero and hence there will be no strain in the layer of the beam at neutral axis.

Let us recall the concept of Hook's Law

According to Hook's Law, within elastic limit, stress applied over an elastic material will be directionally proportional to the strain produced due to external loading and mathematically we can write above law as mentioned here.

$$\text{Stress} = E \cdot \text{Strain}$$

$$\text{Strain} = \text{Stress} / E$$

$$\text{Strain} = \sigma / E$$

Where E is the Young's Modulus of elasticity of the material

Let us consider the above equation and putting the value of strain secure above, we will have following equation as mentioned here.

$$\sigma / E = y / R$$

$$\sigma = (y / R) \times E$$

Therefore, bending stress on the layer will be given by following formula as displayed here

$$\sigma_b = \frac{E}{R} \times y$$

We can conclude from above equation that stress acting on layer of the beam will be directionally proportional to the distance y of the layer from the neutral axis.

Therefore, there will be force acting on the layers of the beams due to these stresses and hence there will be moment of these forces about the neutral axis too.

Total moment of these forces about the neutral axis for a section will be termed as moment of resistance of that section. As we have already assumed that we are working here with a beam having rectangular cross-section and let us consider the cross-section of the beam as displayed here in following figure.

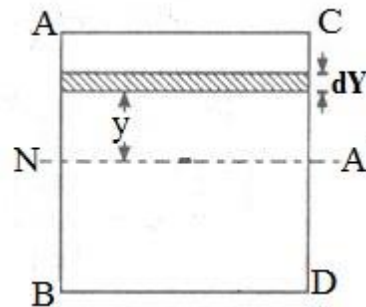

Let us assume one strip of thickness dy and area dA at a distance y from the neutral axis as displayed in above figure. Let us determine the force acting on the layer due to bending stress and we will have following equation

$$dF = \sigma \times dA$$

Let us determine the moment of this layer about the neutral axis, dM as mentioned here

$$dM = dF \times y$$

$$dM = \sigma \times dA \times y$$

$$dM = (E/R) \times y \times dA \times y$$

$$dM = (E/R) \times y^2 \times dA$$

Total moment of the forces on the section of the beam around the neutral axis, also termed as moment of resistance, could be secured by integrating the above equation and we will have

$$dM = (E/R) \times y^2 \times dA$$

$$M = \frac{E}{R} \int y^2 \times dA$$

$$I = \int y^2 \times dA$$

$$M = \frac{E}{R} \times I$$

$$\frac{M}{I} = \frac{E}{R}$$

Let us consider the above equation of moment of resistance and equation that we have secured for bending stress in case of bending action; we will have following equation which is termed as bending equation or flexural formula of bending equation.

$$\frac{M}{I} = \frac{\sigma}{y} = \frac{E}{R}$$

USE OF THE EQUATION

Bending theory is also known as flexure theory is defined as the axial deformation of the beam due to external load that is applied perpendicularly to a longitudinal axis which finds application in applied mechanics.

CONCEPT OF MOMENT OF RESISTANCE

When a beam is subjected to bending moment, the stresses of opposite nature develop on the sections above and below the neutral axis. These internal forces have certain moments about neutral axis. The sum of moments of internal forces about neutral axis is known as moment of resistance or flexural strength.

$$\frac{M}{I} = \frac{\sigma}{Y}$$

$$M = \sigma \frac{I}{Y}$$

$$M = \sigma Z$$

Where Z is known as Section Modulus. So, moment of resistance is directly proportional to its section modulus of beam.

BENDING STRESS DIAGRAM

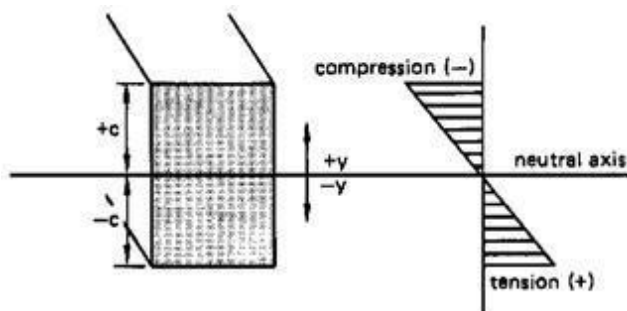
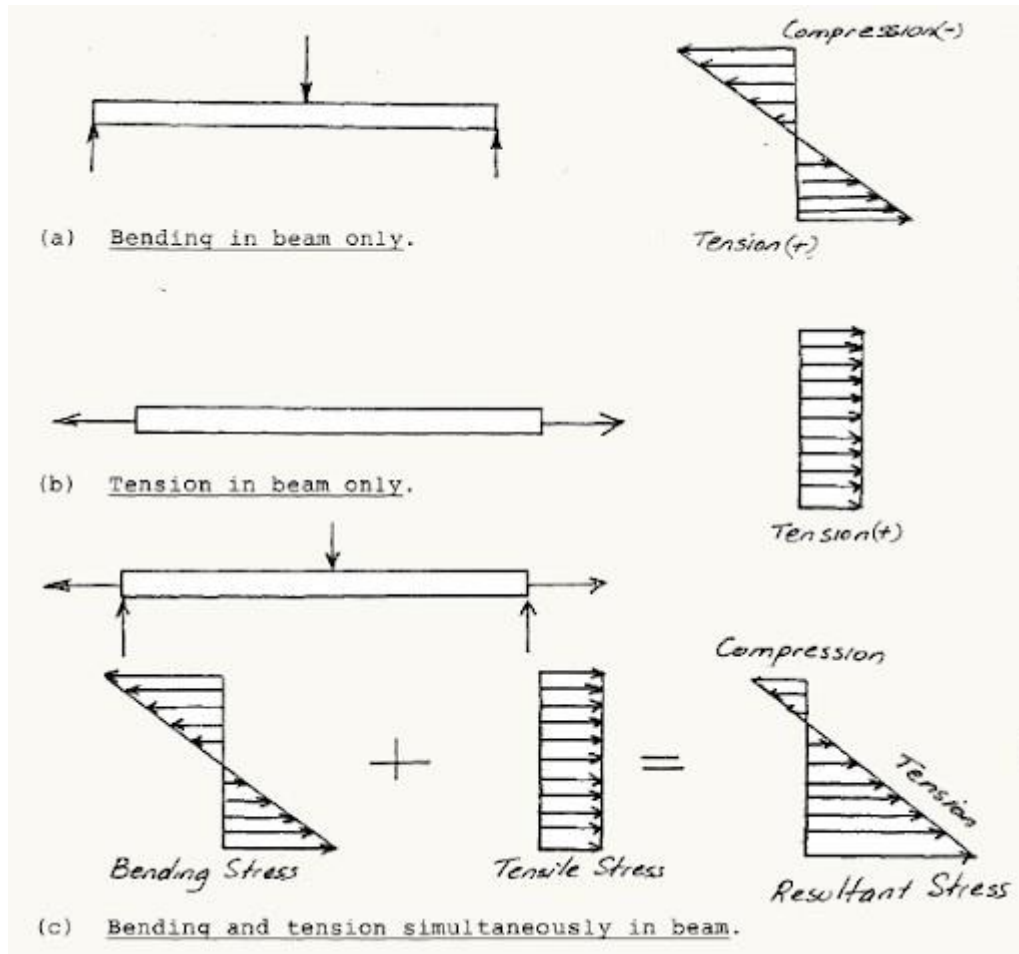

Figure Bending Stress Distribution in a Beam



SECTION MODULUS FOR RECTANGULAR, CIRCULAR AND SYMMETRICAL I SECTION

It is termed as the ratio of second moment of area and distance from N.A (Neutral axis) to the extreme fiber. Also it is the measure of strength of given member. The stress in the outermost section of beam is computed with the help of section modulus. It is indicated by S.

Section modulus is indicated as follows:

$$S = \frac{I}{y}$$

Here, I is “moment of inertia” and y is distance from “neutral axis” to top or bottom of fiber. Section modulus depends only on the cross section shape of the beam. Cross section shapes like rectangular, square, circular, I section and T, composite section etc.

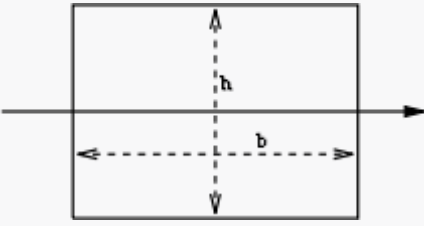
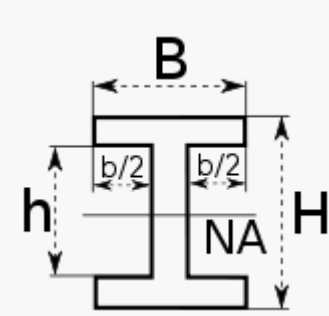
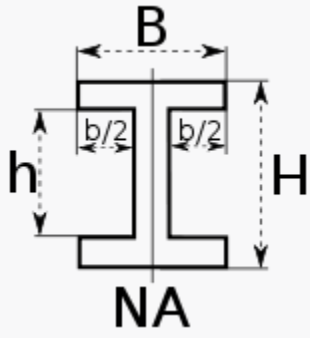
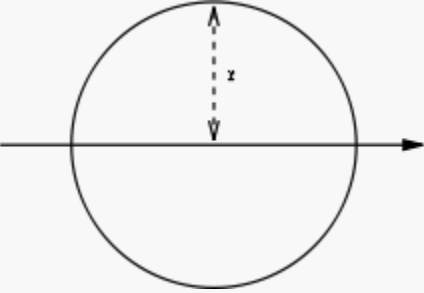
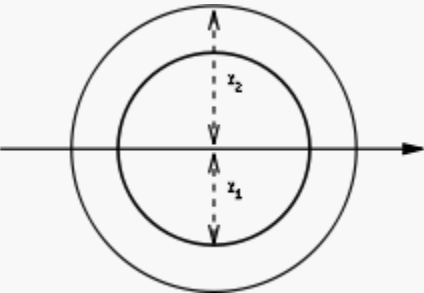
Cross-sectional shape	Figure	Equation
Rectangle		$S = \frac{bh^2}{6}$
doubly symmetric <u>I-section</u> (major axis)		$S_x = \frac{BH^2}{6} - \frac{bh^3}{6H}$ $S_x = \frac{I_x}{y}$ <p>with $y = \frac{H}{2}$</p>
doubly symmetric <u>I-section</u> (minor axis)		$S_y = \frac{B^2(H-h)}{6} + \frac{(B-b)^3h}{6B}$
Circle		$S = \frac{\pi d^3}{32}$
Circular hollow section		$S = \frac{\pi (r_2^4 - r_1^4)}{4r_2} = \frac{\pi (d_2^4 - d_1^4)}{32d_2}$

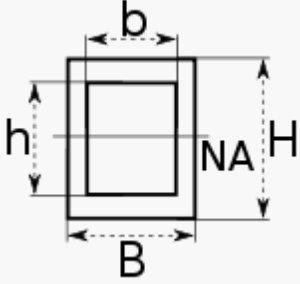
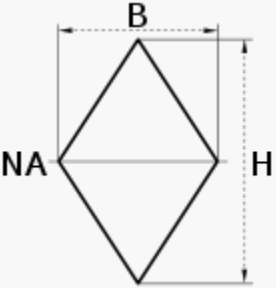
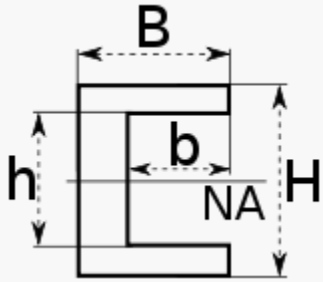
Rectangular hollow section		$S = \frac{BH^2}{6} - \frac{bh^3}{6H}$
Diamond		$S = \frac{BH^2}{24}$
C-channel		$S = \frac{BH^2}{6} - \frac{bh^3}{6H}$

CALCULATION OF MAXIMUM BENDING STRESS IN BEAMS OF RECTANGULAR, CIRCULAR, AND T SECTION

Maximum bending stress in Beam of Rectangular section

Example 5.3. A simply supported beam of 5 m span and of rectangular section of 60 mm × 100 mm placed with longer leg vertical carries a uniformly distributed load of 5000 N/m over the whole span. Calculate the maximum bending stress developed in the section at

- (i) supports,
- (ii) 1 m from the supports,
- (iii) middle of span.

Solution. Given, $l = 5\text{ m} = 5000\text{ mm}$, $b = 60\text{ mm}$, $d = 100\text{ mm}$, $w = 5000\text{ N/m}$.

M.O.I. about horizontal centroidal axis,

$$I_{xx} = \frac{bd^3}{12} = \frac{60 \times 100^3}{12}$$

$$= 5 \times 10^6 \text{ mm}^4$$

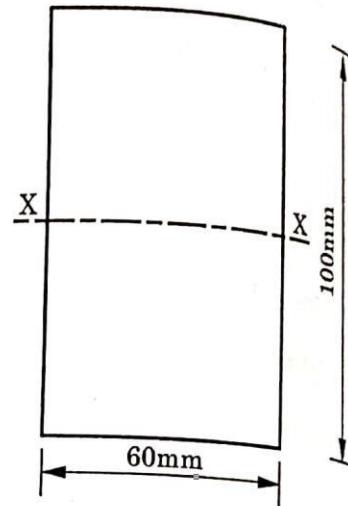

Fig. 5.12 (a)

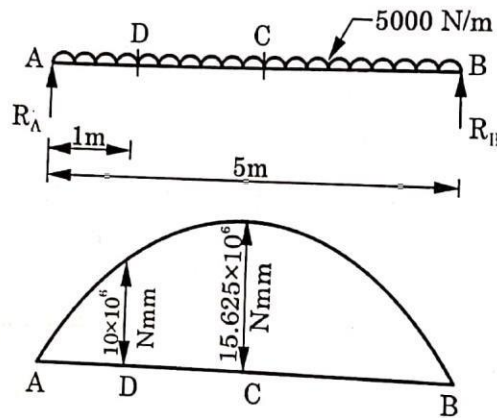

Fig. 5.12(b)

For equilibrium of beam,

$$R_A + R_B = 5,000 \times 5 = 25,000\text{ N}$$

As the beam is symmetrically loaded, therefore reactions at both the supports will be equal.

$$\therefore R_A = R_B = \frac{25000}{2} = 12500 \text{ N}$$

$$\text{B.M. at support A} = 0$$

$$\begin{aligned} \text{B.M. at D (i.e. 1 m from support A)} &= 12500 \times 1 - 5000 \times 1 \times \frac{1}{2} \\ &= 10,000 \text{ Nm} \\ &= 10 \times 10^6 \text{ Nmm} \end{aligned}$$

$$\begin{aligned} \text{B.M. at C (middle of span)} &= 12500 \times \frac{5}{2} - 5000 \times \frac{5}{2} \times \frac{5}{4} \\ &= 31250 - 15625 = 15625 \text{ Nm} \\ &= 15.625 \times 10^6 \text{ Nmm} \end{aligned}$$

$$\text{B.M. at support B} = 0$$

Maximum bending stress (for any section) will be at the extreme fibre (i.e. $\frac{d}{2}$ from N.A.).

$$\therefore y = \frac{100}{2} = 50 \text{ mm}$$

We know that

$$\frac{M}{I} = \frac{\sigma}{Y}$$

$$\text{or } \sigma = \frac{M}{I} \times y$$

$$\text{Bending stress at supports} = 0 \text{ Ans.}$$

$$\begin{aligned} \text{Bending stress at 1 m from supports, } \sigma &= \frac{M}{I} y \\ &= \frac{10 \times 10^6 \times 50}{5 \times 10^6} = 100 \text{ N/mm}^2 \text{ Ans.} \end{aligned}$$

$$\begin{aligned} \text{Bending stress at mid of span} &= \frac{M}{I} y \\ &= \frac{15.625 \times 10^6 \times 50}{5 \times 10^6} \\ &= 156.25 \text{ N/mm}^2 \text{ Ans.} \end{aligned}$$

Maximum bending stress in Beam of Circular and T section

Example 5.12. The cross section of cast iron beam is shown in the fig. 5.25. This beam is simply supported at the ends and carries a uniformly distributed load of 20 kN/m. If the span of the beam is 3m, determine the maximum tensile and compressive stresses in the beam.

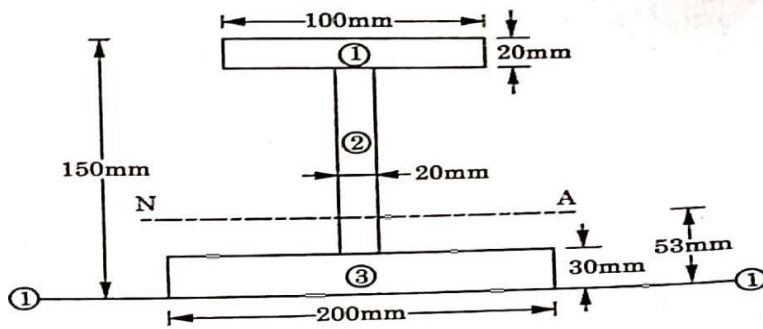

Fig. 5.25

Let us split this I- section into three components- Component (1), component (2) and component

(3).

Component	Area(A) (mm ²)	Centroidal Distance y from Axis 1-1 (mm)	Ay (mm ³)	Ay ² (mm ⁴)	I _{self} (mm ⁴)
1.	2000	140	280000	39200000	$\frac{10 \times (20)^3}{12} = 66667$
2.	2000	80	160000	12800000	$\frac{20 \times (100)^3}{12} = 1666667$
3.	6000	15	90000	1350000	$\frac{20 \times (30)^3}{12} = 450000$
	$\Sigma A = 10000$		$\Sigma Ay = 530000$	$\Sigma Ay^2 = 53350000$	$\Sigma I_{self} = 2183334$

Distance of centroidal axis XX (N.A.) from axis 1-1,

$$\begin{aligned} \bar{y} &= \frac{\Sigma Ay}{\Sigma A} \\ &= \frac{530000}{10000} \\ &= 53 \text{ mm} \end{aligned}$$

$$\begin{aligned} I_{1-1} &= \Sigma I_{self} + \Sigma Ay^2 \\ &= 2183334 + 53350000 \\ &= 55533334 \text{ mm}^4 \end{aligned}$$

But

$$I_{1-1} = I_{XX} + (\Sigma A) \cdot \bar{y}^2$$

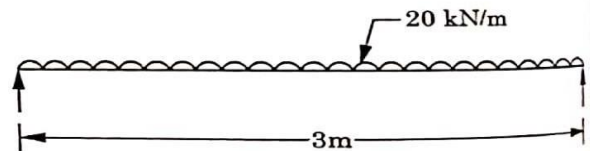

Fig. 5.26

$$55533334 = I_{xx} + 10000 \times (53)^2$$

or

$$I_{xx} = 27443334 \text{ mm}^4.$$

$$\begin{aligned} \text{Maximum B.M., } M &= \frac{wl^2}{8} = \frac{20 \times 10^3 \times 3 \times 3 \times 1000}{8} \\ &= 22.5 \times 10^6 \text{ Nmm} \end{aligned}$$

For a simply supported beam, the tensile stress will be at the extreme bottom fibre and compressive stress will be at the extreme top fibre.

Maximum tensile bending stress (at bottom fibre) :

Distance of extreme bottom fibre from N.A.,

$$y_t = 53 \text{ mm}$$

$$\begin{aligned} \sigma_t &= \frac{M}{I} y_t = \frac{22.5 \times 10^6}{27443334} \times 53 \\ &= 43.453 \text{ N/mm}^2 \end{aligned}$$

Maximum compressive bending stress (at top fibre) :

Distance of extreme top fibre from N.A.,

$$y_c = 150 - 53 = 97 \text{ mm}$$

$$\begin{aligned} \therefore \sigma_c &= \frac{M}{I} y_c = \frac{22.5 \times 10^6}{27443334} \times 97 \\ &= 79.527 \text{ N/mm}^2 \end{aligned}$$

Hence, maximum tensile stress (bottom fibre) = 43.453 N/mm² **Ans.**

Maximum compressive stress (top fibre) = 79.527 N/mm² **Ans.**

6. COLUMNS

CONCEPT OF COLUMN, MODES OF FAILURE

Column

Column is basically defined as a vertical member of a structure and it will be subjected with vertical compressive load. Line of action of compressive load will pass through the axis of the column or sometime also parallel to the axis of the column. A member of structure will be termed as column if it is vertical and it's both ends are fixed rigidly and also subjected with axial vertical compressive load.

Let us see here few important points in respect of concept of columns

- Columns will be subjected with only axial vertical compressive loads
- Columns are basically vertical members in structures
- Column will be longer in length as compared to strut
- Both ends of column will be fixed rigidly
- Normally, columns carry heavy vertical axial compressive loads
- Cross-sectional dimensions of columns will be usually large
- Applications of columns are usually seen in concrete and steel buildings

Types of columns

- Long columns
- Short columns

Long column

Long column is basically defined as the column in which the ratio of effective length of the column to the least lateral dimension of the column is more than 12.

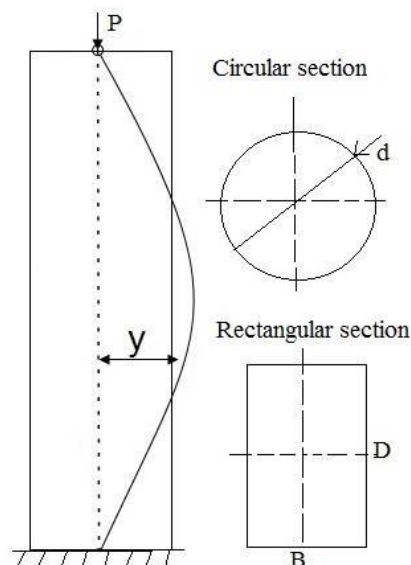

Important characteristics in long column

- Long columns will fail only because of buckling or bending.
- For long column, Euler's theory will be applicable.
- For long column, Lateral dimensions will be quite small as compared with the length of the column.
- For long column, Slenderness ratio will be more than 45.
- For long column, Ratio of effective length of the column to the least lateral dimension of the column will be more than 12.
- For long column, Load carrying capacity will be reduced with increase in length of the column.

Short column

Short column is basically defined as the column in which the ratio of effective length of the column to the least lateral dimension of the column is less than 12.

Important characteristics in short column

- Short columns will fail only because of crushing or direct compression.
- For short column, Rankine's theory will be applicable.
- For short column, Lateral dimensions will be quite large as compared with the length of the column.
- For short column, Slenderness ratio will be less than 45.
- For short column, Ratio of effective length of the column to the least lateral dimension of the column will be less than 12.
- For short column, Load carrying capacity will be increased with decrease in length of the column.

MODES OF FAILURE

Columns fail in two conditions

- Compression Failure
- Buckling Failure

Compression Failure: Compression failure is the material itself crushing or yielding not the column. Shorter and wider column normally fails under compression failure. When the axially loaded stress exceeds allowable stress, compression failure occurs. Concrete starts to fail or bulge as shown in the picture.

Buckling Column: Buckling failure occurs in long column (slender column) where the columns displace laterally or horizontally.

Buckling load, crushing load

➤ **Buckling Load**

When a column will be subjected to axial compressive loads, there will be developed bending moment and hence bending stress in the column. Column will be bent due to this bending stress developed in the column. Load at which column just bends or buckles will be termed as buckling or crippling load.

➤ **Crushing Load**

Crushing load is the minimum load which crushes the column material. Value of buckling load will be smaller than crushing load on the same column. During the design of column, neither crushing load nor buckling is load considered. But, little lesser value of load is considered which is coming on column. That value of load is known as safe load. Structures remain safe under safe load.

Slenderness Ratio

Slenderness ratio of column is basically defined as the ratio of effective length of the column to the least radius of gyration. Slenderness ratio will be given in numbers because it is one ratio and hence slenderness ratio will not have any unit. Slenderness ratio is usually displayed by Greek letter λ

Slenderness ratio = Effective length of the column/ Least radius of gyration

$$\lambda = L_e / k$$

Effective length

The effective column length can be defined as the length of an equivalent pin-ended column having the same load-carrying capacity as the member under consideration. The smaller the effective length of a particular column, the smaller its danger of lateral buckling and the greater its load carrying capacity.

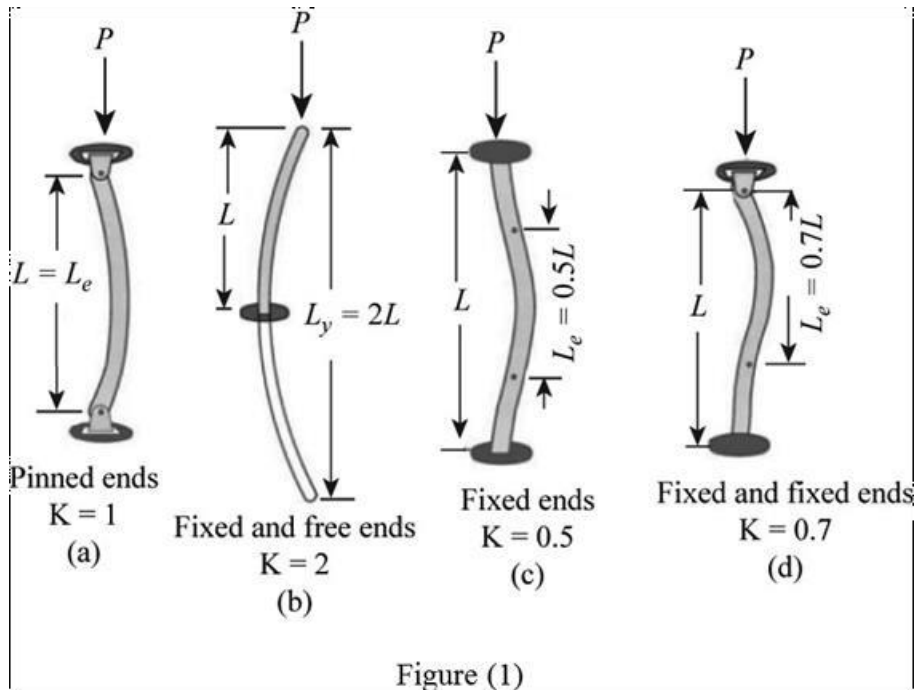

End Restrain

Effective length of a column is calculated after knowing the column end conditions. Effective length changes with the change in column end conditions. Following are the column end conditions.

1. Both Ends Hinged
2. Both Ends Fixed
3. One End Fixed and Other Hinged
4. One End Fixed and Other Free

BOTH ENDS HINGED

This is the standard column end condition. Effective length in this condition is equal to the length of column. Effective length of other end conditions can be found with reference to this condition. In this condition, both ends of column are either pinned, pivoted or rounded. As shown in figure below;

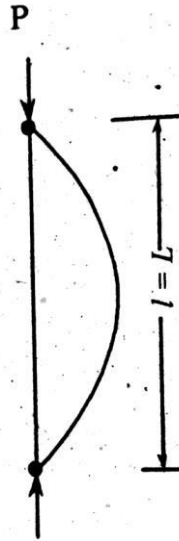

Fig.8.3 Both ends hinged

$$l = L$$

Where,

l = Equivalent length

L = Actual Length

BOTH ENDS FIXED

This is the strongest column end condition. Both ends fixed column carries maximum load and effective length for this condition is considered as half of total column length. Column load bearing capacity increases with the decrease in column equivalent length. As shown in figure below;

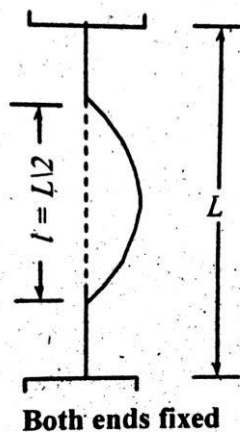

Both ends fixed

$$l = L/2$$

Where,

l = Equivalent length

L = Actual Length

ONE END FIXED AND OTHER HINGED

In this condition, one end of a column is stronger while the other end is very weak. Equivalent length for this end is as following;

$$l = L/\sqrt{2}$$

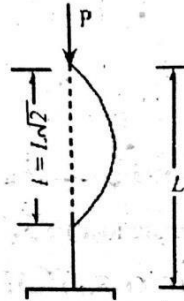

One end fixed, other hinged

ONE END FIXED AND OTHER FREE

This end condition makes column to bear the smallest load than all other end conditions. Column in such condition is very weak. Equivalent length for one end fixed and other free is as following;

$$l = 2L$$

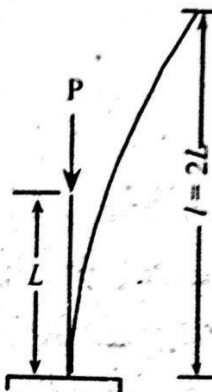

One end fixed other free

FACTORS EFFECTING STRENGTH OF A COLUMN

The strength of a column depends upon the following factors:

- End conditions of the column,
- Slenderness ratio of the column (which depends upon the length and cross-section of the column),
- Material of the column.

STRENGTH OF COLUMN BY EULER FORMULA WITHOUT DERIVATION

The following assumptions are made while deriving Euler's formula:

1. The material of the column is homogeneous and isotropic.
2. The compressive load on the column is fully axial.
3. The column fails only by buckling.
4. The weight of the column is neglected.
5. The column is initially straight and buckles suddenly at a particular load.
6. Pin joints are friction-less and fixed ends are rigid.
7. The cross-section of the column is uniform throughout its length.
8. The length of the column is very large as compared to the cross-sectional dimensions of the column.
9. The direct stress is very small as compared to the bending stress.

EULER FORMULA

$$P_e = \frac{\pi^2 EI}{L^2}$$

P_e = Euler's buckling load or crippling load.

E = Modulus of elasticity of column material.

I = Minimum moment of inertia. (lesser value of I_{XX} and I_{YY})

L = Equivalent length of column

6.9. RANKINE GOURDAN FORMULA (WITHOUT DERIVATION)

It has been shown that Euler's formula is valid for long column having l/k ratio greater than a certain value for a particular material. Euler's formula does not give a reliable result for short column and length of column intermediate between very long to short. An empirical formula has been proposed by Rankine for columns of all lengths

$$P = \frac{\sigma_c \cdot A}{1 + \alpha \left(\frac{L_e}{k} \right)^2}$$

where P = Buckling load

σ_c = Ultimate crushing stress for the column material

A = Cross-sectional area of column

$k =$ Least radius of gyration of the section

$L_e =$ Equivalent length of the column

α is a constant. Its value is given by :

$$\alpha = \frac{\sigma_c}{\pi^2 E}$$

Where E = Young's modulus of the column material

7. TORSION

CONCEPT OF TORSION, DIFFERENCE BETWEEN TORQUE AND TORSION

➤ Concept Of Torsion

Torsion describes a “twisting” effect, where different parts of an object undergo different angular displacements (referred to as the “angle of twist”) about the rotational axis. To create torsion, a torque is necessary.

Torsion happens when the torque causes a shear stress to be applied on the body. When the shear stress applied to different parts of the body is different, they undergo different amounts of angular displacements. The maximum angle of twist occurs at the ends of the object while the middle experiences a zero angle of twist.

➤ Difference Between Torque And Torsion

Torque is a measureable concept, whereas torsion is a concept, which is mathematically projected by the shear stress or the twist angle.

Torque depends only on the magnitude, directions and the separation of the forces applied, while torsion depends on the torque, the type of material and the shape of the object.

Torque requires at least one force and torsion requires at least two forces to happen.

DERIVATION OF TORSION EQUATION, USE OF TORSION EQUATION FOR CIRCULAR SHAFT, (SOLID AND HOLLOW)

➤ Derivation of Torsion Equation

Torsion equation or torsion constant is defined as the geometrical property of a bar’s cross-section that is involved in the axis of the bar that has a relationship between the angle of twist and applied torque whose SI unit is m⁴. The torsion equation is given as follows:

$$\frac{T}{J} = \frac{\tau}{R} = \frac{C \theta}{L}$$

Following are the assumptions made for the derivation of torsion equation:

- The material is homogeneous (elastic property throughout)
- The material should follow Hook’s law
- The material should have shear stress proportional to shear strain
- The cross-sectional area should be plane

- The circular section should be circular
- Every diameter of the material should rotate through the same angle
- The stress of the material should not exceed the elastic limit.

Consider a solid circular shaft with radius R that is subjected to a torque T at one end and the other end under the same torque.

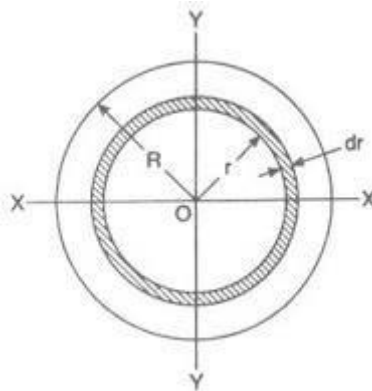

R = Radius of the circular shaft

D = Diameter of the circular shaft

dr = Thickness of small elementary circular ring

r = Radius of the small elementary of circular ring

q = Shear stress at a radius r from the centre of the circular shaft

τ = Shear stress at outer surface of shaft

dA = Area of the small elementary of circular ring

$$dA = 2\pi \times r \times dr$$

Shear stress, at a radius r from the centre, could be determined as mentioned here

$$q/r = \tau / R$$

$$q = \tau \times r/R$$

Turning force due to shear stress at a radius r from the centre could be determined as mentioned here

$$dF = q \times dA$$

Twisting moment at the circular elementary ring could be determined as mentioned here

$$dT = \text{Turning force} \times r$$

$$dT = \tau/R \times 2\pi r^3 dr$$

$$dT = \tau/R \times r^2 \times (2\pi \times r \times dr)$$

$$dT = \tau/R \times r^2 \times dA$$

Total torque could be easily determined by integrating the above equation between limits 0 and R

Therefore total torque transmitted by a circular solid shaft could be given in following way as displayed here in following figure.

$$T = \frac{\tau}{R} \int_0^R r^2 \times dA$$

Let us recall here the basic concept of Polar moment of inertia and we can write here the formula for polar moment inertia. Further, we will use this formula of polar moment of inertia in above equation.

Polar moment of inertia

$$J = \int r^2 dA$$

Therefore total torque transmitted by a circular solid shaft could be given by following equation as mentioned here.

$$T = \frac{\tau}{R} \times J$$

$$\frac{T}{J} = \frac{\tau}{R}$$

$$\frac{T}{J} = \frac{C \theta}{L}$$

Considering above two equations, we can write here the expression for torsion equation for circular shaft as displayed here.

$$\frac{T}{J} = \frac{\tau}{R} = \frac{C \theta}{L}$$

8. SPRING

➤ Spring

Spring is an elastic member whose main function is to deflect under the action of load and recovers its original shape when the load is removed. It is a mechanical component.

➤ Function of Spring:

- To absorb the shocks or Vibration as in-car springs, railway buffers, etc.
- To measure the forces as in a spring balance.
- Apply forces in brakes and clutches to stop the vehicles.
- The function is to store the energy as in clocks, toys, etc.
- Control the motion as in cams and followers by maintaining contact between two elements.

➤ Types of Spring:

- Helical Spring
- Laminated or leaf Spring

• Helical Spring

The helical spring is made from a wire, usually of circular cross-section, that is bent in the form of a helix. There are two basic types of helical springs: compression spring and tension spring.

In helical compression spring, the external force tends to shorten the spring. In other words, the spring is compressed. In helical tension spring, the external force tends to lengthen the spring. In other words, the spring is elongated.

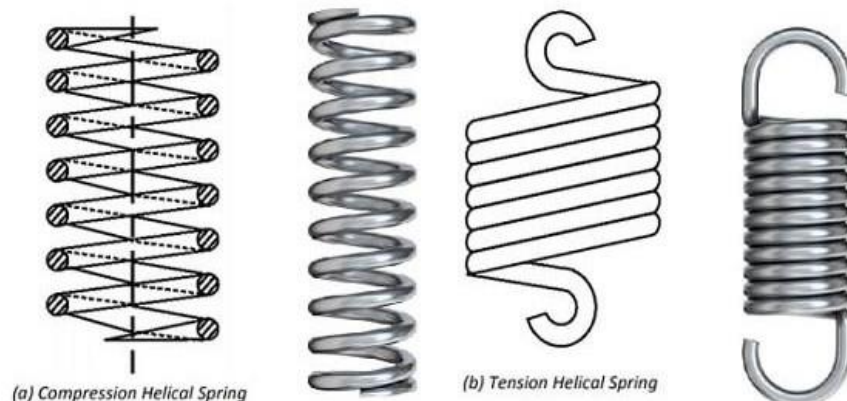

- **Laminated or Leaf Spring**

Multi-leaf spring is widely used for the suspension of trucks and railway wagons. It consists of a series of flat plates, usually of semi-elliptical shape. The flat plates are called leaves of the spring. The leaf at the top has a maximum length. The longest leaf at the top is called a master leaf. The leaves have graduated lengths. The length gradually decreases from the top leaf to the bottom leaf. It is bent at both ends to form the spring eye. Two bolts are inserted through these eyes to fix the leaf spring to the automobile body. The leaves are held together utilizing two U-bolts and a center clip.

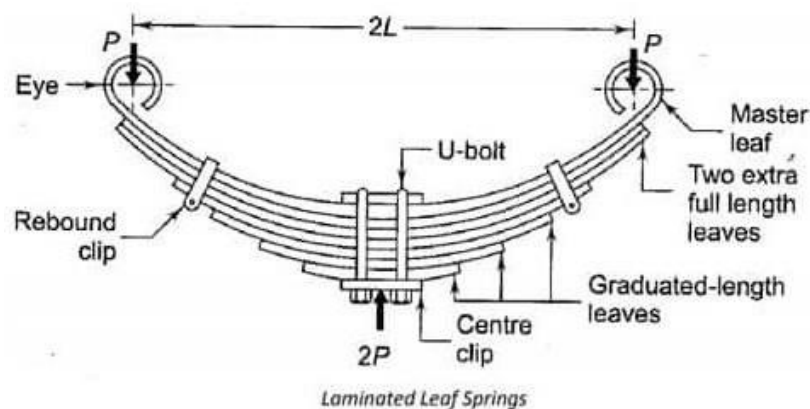

Selection of material for the spring wire depends upon the following factors:

1. The load acting on the spring.
2. The range of stress through which the spring operates.
3. The limitations on mass and volume of spring.
4. The expected fatigue life.
5. The environmental conditions in which the spring will operate such as temperature and corrosive atmosphere.
6. The severity of deformation encountered while making the spring.

CLOSED COIL HELICAL SPRINGS SUBJECTED TO AXIAL LOAD AND CALCULATION OF:

- **STRESS DEFORMATION**
- **STIFFNESS AND ANGLE OF TWIST AND STRAIN ENERGY**
- **STRAIN ENERGY AND PROOF RESILIENCE**

Closed coiled helical spring

Closed coiled helical springs are also termed as tension springs as such springs are designed to resist the tensile load and twisting load. In simple, we can say

that closed coiled helical springs are those springs which are used in such applications, where tensile or twisting loads are present. In case of closed coiled helical spring, spring wires are wound tightly. Hence such springs will have very small pitch. Closed coiled helical springs wires are very close to each other and hence, spring turns or coils will lie in same plane.

In case of closed coiled helical spring, turns or coils of such spring will be located at right angle to the helical axis. Closed coiled helical spring, as displayed here, carrying an axial load W . In case of closed coiled helical spring, helix angle will be small and it will be less than 10° . Therefore, we will neglect the bending effect on spring and we will only consider the effect of torsional stresses on the coils of closed coiled helical spring.

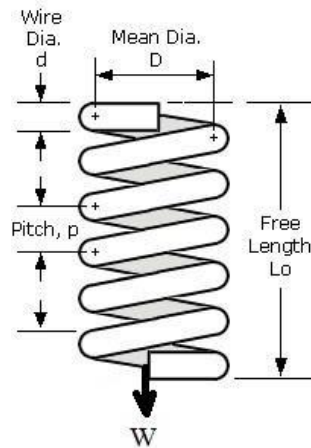

Let us consider the following terms from above figure of closed coil helical spring.

d = Diameter of spring wire or coil

p = Pitch of the helical spring

D = Mean diameter of spring

R = Mean radius of spring

n = Number of spring coils

W = Load applied on spring axially

C = Modulus of rigidity

τ = Maximum shear stress developed in the spring wire

θ = Angle of twist in wire of spring

L = Length of the spring

δ = Deflection of spring under axial load

As spring is loaded by an axial load W , therefore work will be done over the spring and this work done will be stored in the form of energy in spring. So we will determine here the work done by axial load W over the spring and we will also determine the strain energy stored in the spring.

Expression for deflection developed in spring under axial load could be derived by equating the energy stored in spring with work done on spring.

Strain energy stored in the spring = $(\tau^2/4C) \times$ Volume of the spring

Volume of spring = Area of cross section (V) \times Length of the spring (L)

$V = (\pi/4) \times d^2$

$L = 2\pi Rn$

Strain energy stored in the spring = $(\tau^2/4C) \times$ Volume of the spring

Strain energy stored in the spring = $(\tau^2/4C) \times 2\pi Rn$

Expression for shear stress developed in spring under axial loading

$$\begin{aligned}\tau &= \frac{16 W \times R}{\pi \times d^3} \\ &= \left[\frac{16 W \times R}{\pi \times d^3} \right] \times \frac{1}{4C} \times (\pi/4) \times d^2 \times 2\pi Rn \\ &= \frac{32 W^2 R^3 \cdot n}{C d^4}\end{aligned}$$

Work done on spring

Work done on spring = $(1/2) W \times \delta$

As we know that expression for deflection developed in spring under axial load could be derived by equating the energy stored in spring with work done on spring and therefore we will have following equation as mentioned here.

$$\begin{aligned}(1/2) W \times \delta &= \frac{32 W^2 R^3 \cdot n}{C d^4} \\ \delta &= \frac{64 W R^3 \cdot n}{C d^4}\end{aligned}$$

Stiffness of spring

Stiffness of spring could be easily determined by dividing the load with deflection.

Stiffness of spring = Load (W) / Deflection (δ)

8.2. DETERMINATION OF NUMBER OF PLATES OF LAMINATED SPRING (SEMI ELLIPTICAL TYPE ONLY)

A leaf or laminated spring is basically a simple type of suspension spring usually used for absorbing the shocks in heavy vehicles such as Lorries, railway wagons, cars, trailers and trucks. Leaf spring will be made by number of parallel metal strips of having identical width but different lengths placed one over another as displayed in following figure. As we have seen that leaf springs are made by flat plates and therefore leaf springs are also called as flat springs. In initial situation, all plates of leaf spring will be bent in same radius and will be free to slide one over the other. Once leaf spring will be loaded with rated load, central deflection will be disappeared and all plates will become flat. Semi-elliptical leaf spring is the most popular and widely used leaf spring. It consists of a number of flat plates or leaves of semi-elliptical shape. U-bolts and center clip are used to hold these leaves together. To keep the leaves aligned and avoid lateral shifting, rebound clips are used. Ends of the longest leaf are bent to form eyes. This longest leaf is called 'master leaf' and other smaller leaves are called 'graduated leaves'. One or two extra full length leaves are generally provided along with the master leaf, to increase strength against the transverse shear force. Typical semi-elliptical leaf spring is shown in figure 18.4.

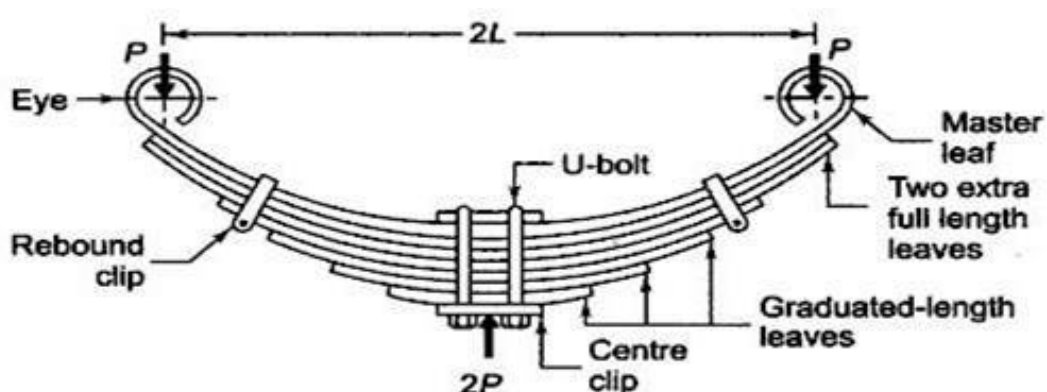

When no external load is acting, the spring is curved or cambered. Camber is the perpendicular distance between the reference line and the master leaf and its magnitude is such that the spring is approximately straight under the max static load. Center of the spring is fixed to the axle of the automobile.

For the analysis purpose, leaves are divided into two groups: i. Master leaf and graduated leaves ii. Extra full length leaves. Let

n_g = number of graduated-length leaves including master leaf

n_f = number of extra full length leaves

n = total number of leaves

b = width of each leaf

t = thickness of each leaf

L = half the length of semi-elliptical spring

F = force applied at the ends of the spring

F_f = part of F taken by extra full length leaves

F_g = part of F taken by graduated leaves and master leaf

Now, this spring can be treated as a simply supported beam of length $2L$, with load $2F$ acting at its centre or for simplification of analysis, half portion of it can be considered as a cantilever of length L , with one end fixed (centre of the spring which is fixed with axle) and load F acting on the other. Now the first group of leaves i.e. master leaf along with the graduated leaves can be considered as a cantilever beam of uniform strength as discussed in previous article. Similarly group of extra full length leaves can be considered as a cantilever beam of uniform cross-section. Therefore the relations given in table 18.1 can be used to write the stress and deflections in these leaves by replacing B with ' $n_f b$ ' and ' $n_g b$ ' and considering the share of load taken by them.

Group of Leaves	Can be Treated as	Maximum Bending Stress	Maximum Deflection
Extra Full Length Leaves	Cantilever Beam of Uniform Cross-section	σ_{b_f} $= \frac{6F_f L}{n_f b t^2}$	δ_f $= \frac{4F_f L^3}{En_f b t^3}$
Master Leaf and Graduated Leaves	Cantilever Beam of Uniform Strength	σ_{b_g} $= \frac{6F_g L}{n_g b t^2}$	δ_g $= \frac{6F_g L^3}{En_g b t^3}$

As deflection in the full length leaves and graduated leaves is equal,

$$\delta_g = \delta_f$$
$$\frac{6F_g L^3}{En_g b t^3} = \frac{4F_f L^3}{En_f b t^3}$$
$$\frac{F_g}{F_f} = \frac{2n_g}{3n_f}$$

Also, $F_g + F_f = F$

$$F_g = \frac{2n_g F}{2n_g + 3n_f} \quad \text{and} \quad F_f = \frac{3n_f F}{2n_g + 3n_f}$$

Solving,

Final relation for stress and deflection can be written as,

$$\sigma_{b_g} = \frac{12FL}{(2n_g + 3n_f)bt^2} \quad \text{and} \quad \sigma_{b_f} = \frac{18FL}{(2n_g + 3n_f)bt^2}$$
$$\delta = \delta_g = \delta_f = \frac{12FL^3}{(2n_g + 3n_f)Ebt^3}$$

And considering that the stress in all the leaves should now be equal,

$$\sigma_b = \sigma_{b_g} = \sigma_{b_f} = \frac{6FL}{nbt^2}$$

END OF THE CONTENTS